

Features

- Assembled in USA
- 0-90 second field replaceable time delay retard
- Easy to read retard time delay adjustment knob
- Mounting secured with integral 1/2" male NPT fitting
- Two SPDT (form C) contacts
- Weatherproof
- Easy to read wire terminal designations



WARNING

- Installation must be performed by qualified personnel and in accordance with all national and local codes and ordinances.
- Shock hazard. Disconnect power source before servicing. Serious injury or death could result.
- Read all instructions carefully and understand them before starting installation. Save instructions for future use. Failure to read and understand instructions could result in improper operation of device resulting in serious injury or death.
- Risk of explosion. Not for use in hazardous locations. Serious injury or death could result.

Description

The Model WFSR-F is a pressure operated switch with an adjustable, instantly recycling pneumatic retard to prevent false alarms due to water pressure variation. The WFSR-F is connected into the alarm port of a wet sprinkler system alarm check valve. Cover incorporates tamper resistant fasteners that require a special key for removal. One key is supplied with each device. For optional cover tamper switch kit, order Stock No. 0090018.

NOTICE

This document contains important information on the installation and operation of the WFSR-F. Please read all instructions carefully and notify the building owner or their authorized representative before any work is done on the fire sprinkler or fire alarm system. A copy of this document is required by NFPA 72 to be maintained on site.

Installation

A male 1/2" NPT pipe fitting is provided for connection to the alarm port of the alarm check valve. No additional mounting or support is required. Allow 5" (12,7cm) to the front of the unit for removal of the cover. Install with the pressure connection down.

Technical Specifications

Conduit Entrances	Two knockouts provided for 1/2" conduit	
Contact Ratings	Two Sets of SPDT (Form C) 15.0 Amps at 125/250VAC 2.0 Amps at 30VDC Resistive	
Dimensions	5 9/16"H x 3 1/2"W x 5 7/8"D (14,1cm H x 8,9cm W x 14,9cm D)	
Enclosure	Cover - Weather/UV/Flame Resistant High Impact Composite Base - Die-cast aluminum	
Environmental Specifications	NEMA 4/IP54 Rated Enclosure suitable for indoor or outdoor use with factory installed gasket when used with appropriate conduit fitting. 40°F to 120°F (4,5°C to 49°C)	
Maximum System Pressure	175 PSI (12,1 BAR)	
Pressure Adjustments:	Factory adjusted to operate between 5 and 8 PSI (0,35 and 0,55 BAR) on rising pressure	
Pressure Connection	1/2" Male NPT	
Service Use:	Automatic Sprinkler One or two family dwelling Residential occupancy up to four stories National Fire Alarm Code	NFPA-13 NFPA-13D NFPA-13R NFPA-72
Weight	1.5 lbs. (3,3 kg.)	

WFSR-F System Location

Fig 1

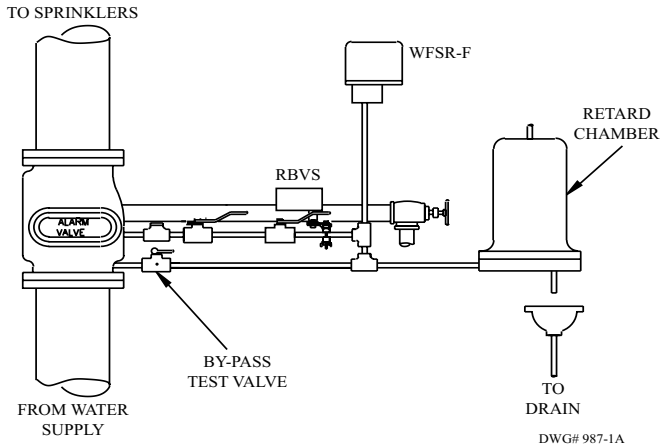
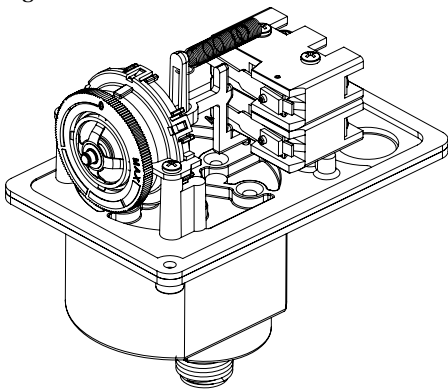

Fig 3



Retard Adjustment: The time delay is factory set at 30 ± 10 seconds. The delay can be adjusted by rotating the retard adjustment knob from 0 to the max setting (60-90 seconds). The time delay should be set at the minimum required to prevent false alarms.

Testing

Operation of the unit is checked by opening the by-pass test valve or inspector's test valve. The frequency of the inspection and testing for the Model WFSR-F and its associated protective monitoring system should be in accordance with applicable NFPA Codes and Standards and/or authority having jurisdiction (manufacturer recommends quarterly or more frequently).

Typical Electrical Connections

Fig 2

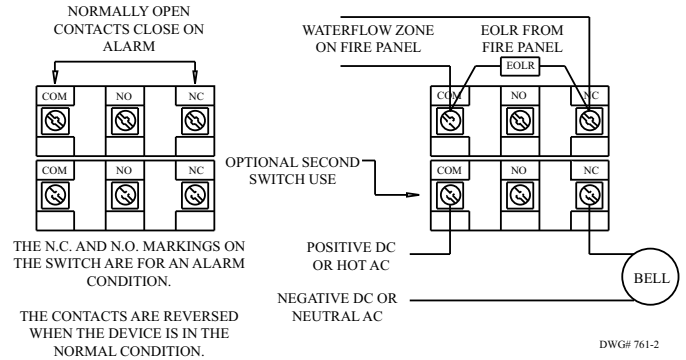

Note: For supervised circuits see "Switch Terminal Connections" drawing and caution note (Fig. 4).

Fig. 4 Switch Terminal Connections Clamping Plate Terminal

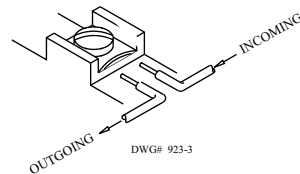

⚠ CAUTION

An uninsulated section of a single conductor should not be looped around the terminal and serve as two separate connections. The wire must be severed, thereby providing supervision of the connection in the event that the wire becomes dislodged from under the terminal.

Typical Wet System

Fig 5

CAUTION

Closing of any shutoff valves between the alarm check valve and the WFSR-F will render the WFSR-F inoperative. To comply with IBC, IFC, and NFPA-13, any such valve shall be electrically supervised with a supervisory switch such as Potter Model RBVS.

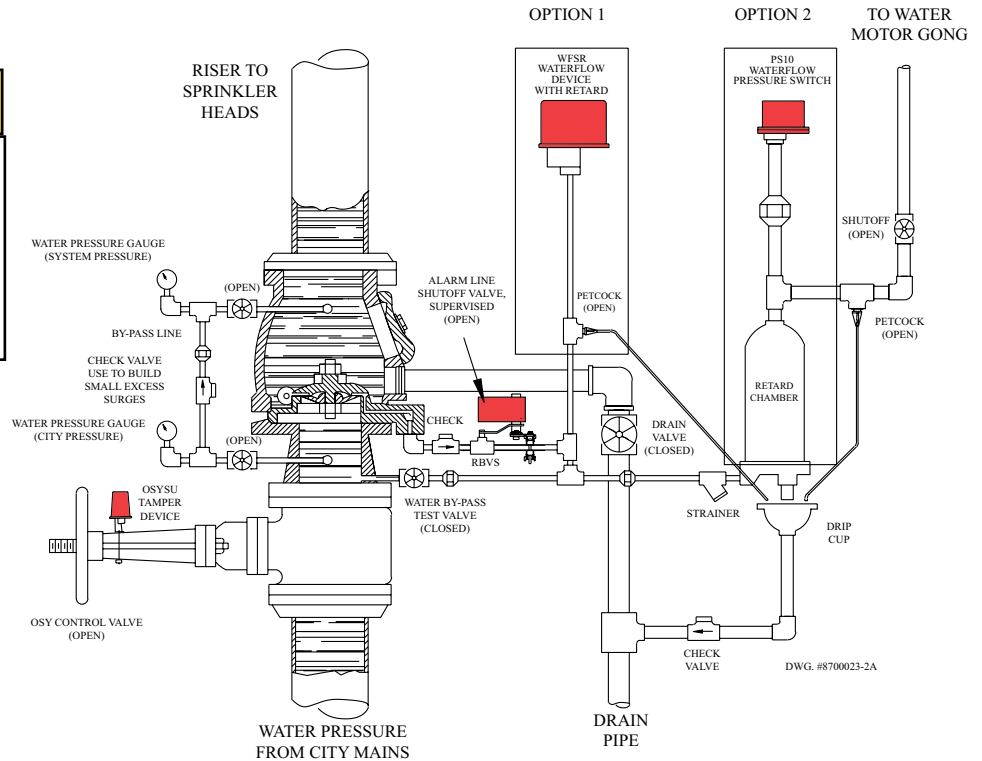

CAUTION

Due to the possibility of unintended discharges caused by pressure surges, trapped air, or short retard times, waterflow switches that are monitoring wet pipe sprinkler systems shall not be used as the sole initiating device to discharge AFFF, deluge, or chemical suppression systems.

NOTICE

Pressure switches have a normal service life of 10-15 years. However, the service life may be significantly reduced by local environmental conditions.

CAUTION

- Do not tighten by grasping the switch enclosure. Use wrenching flats on the bushing only. Failure to install properly could damage the switch and cause improper operation resulting in damage to equipment and property.
- To seal threads, apply Teflon tape to male threads only. Using joint compounds or cement can obstruct the pressure port inlet and result in improper device operation and damage to equipment.
- Do not over tighten the device, standard piping practices apply.
- Do not apply any lubricant to any component of the pressure switch.

Ordering Information

Model	Description	Stock No.
WFSR-F	Waterflow Alarm Switch W/ Retard	1010080
	Cover Tamper Switch Kit	0090018