

### Features

- Complete skid mounted unit – easy plug and play installation
- Integrated 1 HP oil-less air compressor needed for NFPA 13 required 30 minutes fill for 500 gallon system at 40 PSI
- Handles up to 1200 gallons of total sprinkler system capacity (based on NFPA 13 allowable leak rates for a new sprinkler system)
- Premium nitrogen membrane
- UL 508A listed industrial control panel
- Requires only one power connection
- Built-in Programmable Logic Controller for leak detection and air bypass alarm systems
- Form C dry contacts for Building Management System (BMS) notification
- 20 gallon air tank and 30 gallon nitrogen tank
- Fits through standard 32" door
- Includes all filters, relief valves, automatic drains and gauges



### Description

The Potter Nitrogen Generator, NGP-500D, is specifically designed to provide on-site, high purity nitrogen for use in fire protection sprinkler systems. When used as a supervisory gas in fire sprinkler systems, nitrogen slows corrosion, improves the life of your system, and lowers maintenance costs. Potter Nitrogen Generators are fully assembled packages ready to be connected to a new or existing fire sprinkler system. These turn-key systems include all air filtration equipment, an air compressor, nitrogen membrane, as well as tanks required to keep the generator operating at peak efficiency. Potter Nitrogen Generator Systems provide a low cost, reliable, and efficient method of producing a minimum of 98% nitrogen at the point of usage.

The NGP-500D utilizes nitrogen membrane technology for gas separation. Nitrogen membranes are highly effective and a cost conscious way of producing on-site nitrogen. Acting as a filter, the smaller oxygen and water vapor molecules can pass through the membrane quickly. The larger nitrogen molecules are less likely to diffuse through the separator tubes; therefore, they continue downstream to the separator outlet, through the air maintenance device and into the fire protection system. As the system fills with nitrogen, the remaining oxygen molecules in the fire protection system are exhausted by using the Potter IntelliPurge® Nitrogen Purge Valve. The Potter IntelliPurge® Nitrogen Purge Valve will periodically monitor the fire protection system to ensure high purity nitrogen is consistent throughout the sprinkler system.

### Installation

The Potter NGP-500D should be installed in a dry, clean, and well-ventilated room with ambient temperatures above 50°F at all times.

Allow access to the front for service and place the unit in a location that is conveniently located near fire sprinkler system connections and a drain.

The Potter Nitrogen Generator should always be installed in an adequately ventilated room. Nitrogen is nontoxic and largely inert. Rapid release of nitrogen gas into an enclosed space displaces the oxygen and can cause an asphyxiation hazard. Inhalation of nitrogen in excessive concentrations can result in unconsciousness without any warning symptoms.

For detailed installation and operation instructions please refer to the Potter Nitrogen Generator Manual #5401548.

### Technical Specifications

Size (HxWxD)	53" x 41" x 28"
Weight	400 lbs
Power Supply	Available in 115V (18A), 208V (7.7A), 230V (9.0A), single phase and 208V (4.5A), 230V (4.4A), 460V (2.2A) three phase
Fire Sprinkler System Connection	½" Female NPT
Mounting Holes	(4) ½" Ø
Max Operating Pressure	105 PSI
Temperature Range	50°F (10°C) to 110°F (43°C)
Air Purity	ISO Class 1.4.1 or better: Free of water 38°F (3°C) Dew Point, compressor oil (0.008 PPM or .01 mg/m <sup>3</sup> ), hydrocarbons, and particles (<0.01 µm microns)

**Dimensions**

Fig 1

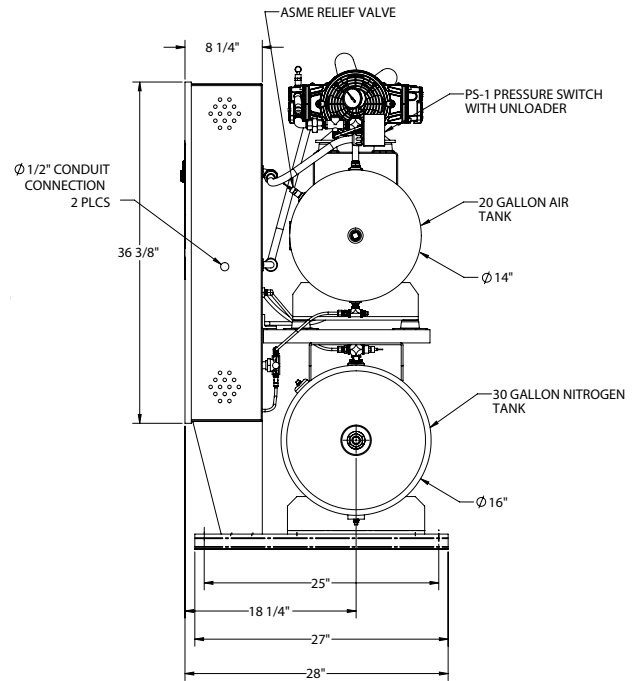
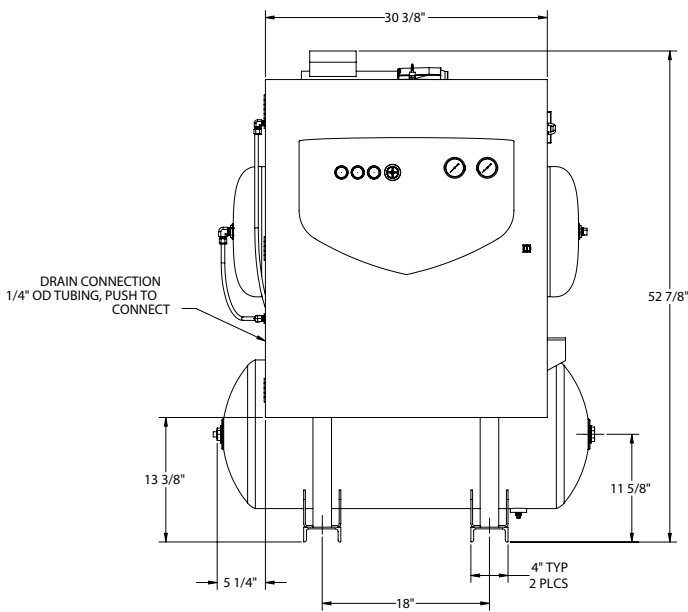
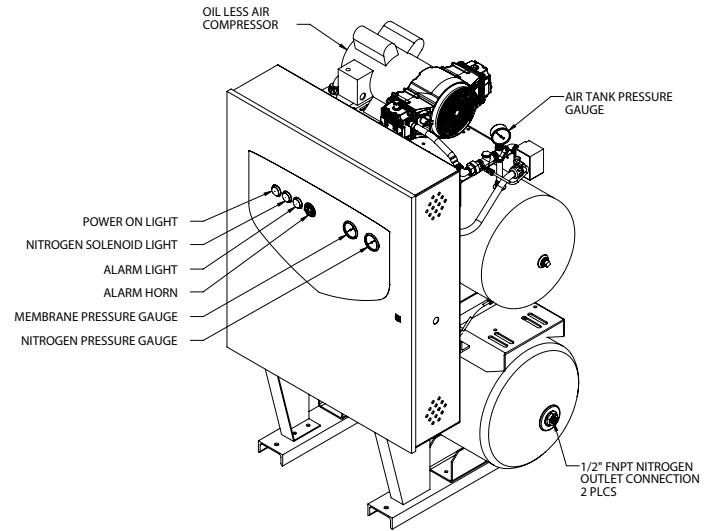
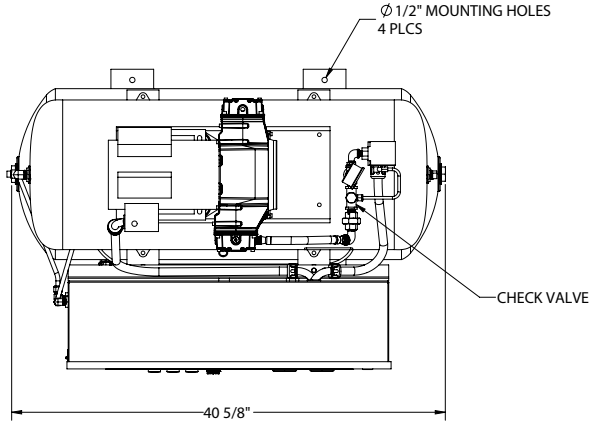

**Ordering Information**

Model	Description	Stock No.
NGP 500D-1A	SINGLE PHASE 115V	1119508
NGP-500D-2A	SINGLE PHASE 208V	1119509
NGP-500D-3A	SINGLE PHASE 230V	1119510
NGP 500D-2B	THREE PHASE 208V	1119511
NGP 500D-3B	THREE PHASE 230V	1119512
NGP 500D-4B	THREE PHASE 460V	1119513

Model	Description	Stock No.
NGP-MK2	Maintenance Kit NGP-250D/500D/M1	1119543
INS-PV	Potter IntelliPurge® Nitrogen Purge Valve	1119478
NGP-SPV	Potter Purge Valve	1119784
NGP-AMD-1	Potter Air Maintenance Device	1119787