

Features

- FM Approved for use in Class I, Division 1 and Zone 1 hazardous locations, AEX db ia IIC (T4 Gb)
- FM Approved for smoke detection performance
- IECEX Zone approved, Ex db ia IIC T4 Gb
- Trouble-free photoelectric operation
- 0-20 mA output for DCS, PLC, integration with milliamp, or relay outputs
- Self-checking circuitry ensures reliable smoke detection
- Alarm, Auxiliary and Fault relays for controlling annunciating devices or fire panel interface
- LED provides a visual indication that an alarm has occurred
- IP44 ingress protection level suitable for onshore or offshore requirements, rugged design for environmental extremes
- Supports Q5016 Duct Mount Kit accessory, able to mount on exterior of ducts
- Visual confirmation of detector alarm, detects smoldering fires
- Ideally suited for classified areas in the petrochemical, oil and gas industry
- CSA Approved, Class C481804, Ex db ia IIC T4



Description

The Det-Tronics® SmokeWatch™ U5015 Explosion Proof Smoke Detector has Division and Zone explosion-proof ratings and is suitable for industrial and commercial applications. The detector is designed to operate effectively with smoldering and rapidly growing fires and contains the ability to annunciate fault ensuring no undisclosed failures. The U5015 Smoke Detector outputs include 0-20 mA, a localized LED, and relays.

Typical applications that use the U5015 include:

- Combustible storage facilities
- Munitions manufacturing
- Volatile chemical storage
- Chemical processing plants
- Petroleum refineries
- Turbine enclosures
- Battery rooms
- HVAC applications

The hot-swappable sensor module is intrinsically safe and allows live maintenance while under power, without de-classifying the hazardous area. The integrated junction box is available in a variety of port configurations for simplified wiring and installation.

Hazard Approval - FM

Class	Division	Groups
I	1	B, C, D (T4)
I	2	A, B, C, D (T4)

Technical Specifications

Operating Draw	12-30 VDC (24 VDC nominal).
Power Consumption	3.5 watts maximum (2.75 watts at 24 Vdc).
Output Relays	Smoke alarm relay, Form C, 5 amperes at 30 Vdc: Smoke alarm relay has normally open/normally closed contacts and normally de-energized operation. Fault relay, Form A, 5 amperes at 30 Vdc: Fault relay has normally open contacts and normally energized operation. Auxiliary relay, Form C, 5 amperes at 30 Vdc: Auxiliary relay has normally open/normally closed contacts and normally de-energized operation.
Temperature Range	Operating: -20°C to +65°C (-4°F to +149°F) Storage: -55°C to +70°C (-67°F to +158°F).
Humidity Range	5 to 95% relative humidity
Ingress Protection	IP44 (Applicable to ceiling mount only).
Current Output	0-20 mA (±0.3 mA) dc current, with maximum loop resistance of 300 ohms from 12-17.9 Vdc, 500 ohms from 18 to 19.9 Vdc, and 600 ohms from 20-30 Vdc.
Terminals	UL/CSA rated for 14-18 AWG or 2.5-0.75 mm ² wire.
Smoke Density	1.5% - 2.5% obscuration per foot. (4.9% - 8.2% obscuration per meter)
Thread Options	3/4 inch NPT or M25 Multi-port models available.
Enclosure Material	Polycarbonate / ABS - Smoke Detector Copper-free aluminum (painted) - Junction Box.
Shipping Weight (Approximate)	7.85 lbs (3.56 kg).

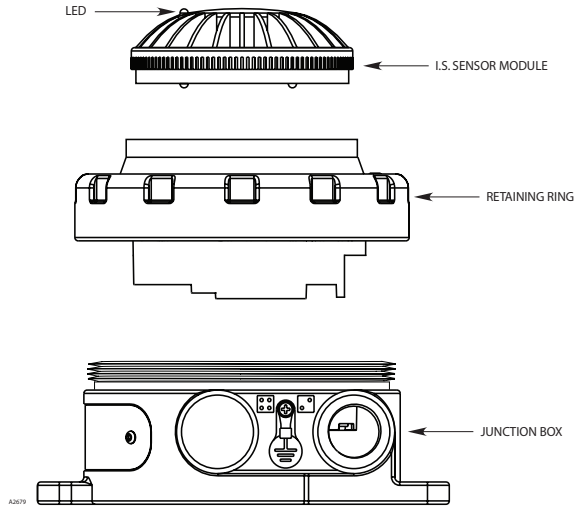

Figure 1—U5015 Components

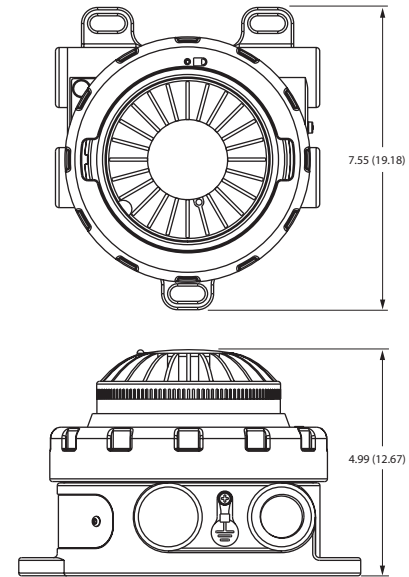

Figure 2—U5015 Dimensions in Inches (cm)

Q5016 Duct Mount Accessory Kit

The Q5016 Duct Mount Accessory is designed for use with the Det-Tronics® SmokeWatch™ U5015 Explosion-Proof Smoke Detector.

This accessory allows for the installation of the smoke detector into duct monitoring applications.

The Q5016 Duct Mount Kit and spare parts are sold separately from the SmokeWatch U5015 smoke detector. There are many different models of SmokeWatch U5015 explosion-proof smoke detector available for purchase.

- Rugged aluminum design for environmental extremes
- Designed to meet UL268A (not certified)
- Designed to meet ingress protection requirements for NEMA 250 Type 4X
- Pilot tubes allow for air velocity ranges of 300 to 4,000 ft/min (91.4 to 1219 m/min)



Ordering Information

Part Number	Ordering Part Number	Description
U5015	Call for Part Number	Explosion Proof Smoke Detector
013901-001	1430534	Q5016-1 Duct mount w/ 1 ft. (0.3 m) inlet tube
013901-003	1430535	Q5016-3 Duct mount w/ 3 ft. (0.9 m) inlet tube
013901-006	1430536	Q5016-6 Duct mount w/ 6 ft. (1.8 m) inlet tube
013901-010	1430537	Q5016-10 Duct mount w/ 10 ft. (3.0 m) inlet tube

Select the option for each Type in the matrix below to determine the complete model number for the U5015 detector.

Model	Description			
U5015	Explosion Proof Smoke Detector			
	TYPE	MATERIAL		
	A	Aluminum (AL)		
		TYPE	# OF PORTS	
		1	1 Port	
		2	2 Port	
		3	3 Port	
		4	4 Port	
		TYPE	# OF PORTS	
		N	3/4" NPT	
		M	M25	
		TYPE	OUTPUTS	
		12	0-20 mA, Relay, Non-Latching	
		13	0-20 mA, Relay, Latching	
		TYPE	APPROVAL	
		A	FM/IECEX/CSA	
		C	CSA	
		F	FM/IECEX	
		R	VNIIFTRI (Russia)	