



TOWERIQ[™]
SIGNAL WHERE IT MATTERS

Guardian4 Public Safety BDA

Guardian4 Public Safety BDA



FEATURES

- Provides improved coverage for Public Safety 700 MHz (FirstNet) and 800 MHz
- 80 dB gain for Public Safety Bands
- Features built-in TowerIQ Sentry™ remote monitoring with ethernet port
- Integrated 7-pin alarm and UPS port for external battery backup
- NEMA-4 rated amplifier housing. No additional NEMA enclosure(s) needed
- Meets the code for NFPA 1221 and IFC 510
- Dry contact 7-pin alarm, UPS and Ethernet port for remote monitoring
- Energy-saving operation allows bands to remain dormant when not in use
- Automatic gain control (AGC)
- A/C 110V or D/C 12- 20V power option
- Independently adjustable frequency attenuation for uplink and downlink (Reduce gain in -1 dBm increments)
- Industry leading 3-year warranty available

TowerIQ's Guardian4 Public Safety Band signal booster amplifies FirstNet signals for crucial communications, delivering consistent signal for First Responders and other public safety officials relying on two-way radio communication inside large buildings.

The Guardian4 is a bi-directional amplifier with a maximum gain of 80 dB on the Public Safety frequency bands, supporting 700 MHz (FirstNet Ready) and 800 MHz.

In the majority of cases, newly constructed buildings with considerable size, or existing buildings that increase capacity by expanding the building footprint are required to have signal strength of -95 dBm or better in designated critical areas – elevators, stairwells, etc. – in order to receive a certificate of occupancy. Guardian4 meets the code for NFPA 1221 and IFC 510 and features a NEMA-4 rated amplifier housing, which eliminates the need for an additional NEMA enclosure.

Additionally, the Guardian4 comes equipped with dry contact 7-pin alarming capability, UPS and Ethernet port enabled remote monitoring. The BDA features sturdy metal construction and is covered by an industry leading 3-year warranty.



Electrical Specifications

Model	Guardian4
Uplink Frequency Range (MHz)	788-805 / 806-816
Downlink Frequency Range (MHz)	758-775 / 851-861
Maximum Gain:	80 dB
Supported Standards:	Public Safety 700 and 800 MHz
Gain Adjustment:	31 dB
Noise Figure:	≤ 5 dBm
Impedance:	50Ω
VSWR:	≤ 2.0
Power Input:	DC 12- 20V; AC 110V; 60 Hz
Maximum RF Output Power:	+27 dBm (DL), +26 dBm (UL)
P1dB:	31.5 dBm
Propagation delay	0.03 Microseconds
Operation Temperature:	-4°F to +131°F
Power Consumption	35W
FCC ID:	2AXVJGuard-2QR
Certifications	FCC Part 90 / UL: 60950-1

Technical Specifications

Dimensions	25 x 19 x 9 in
DL Frequency Range	758-775/ 851-861 MHz
Gain Adjustment	31 dB
Max Gain	80 dB
Max RF Output Power	+27 dBm (DL) +26 dBm (UL)
Noise Figure	≤ 5 dB
P1dB	31.5 dBm
Power Consumption	35W
RF Connections	N Female
UL Frequency Range	788-805/ 806-816 MHz
VSWR	≤ 2.0
Weight	54 lbs

Example Building Component Layout

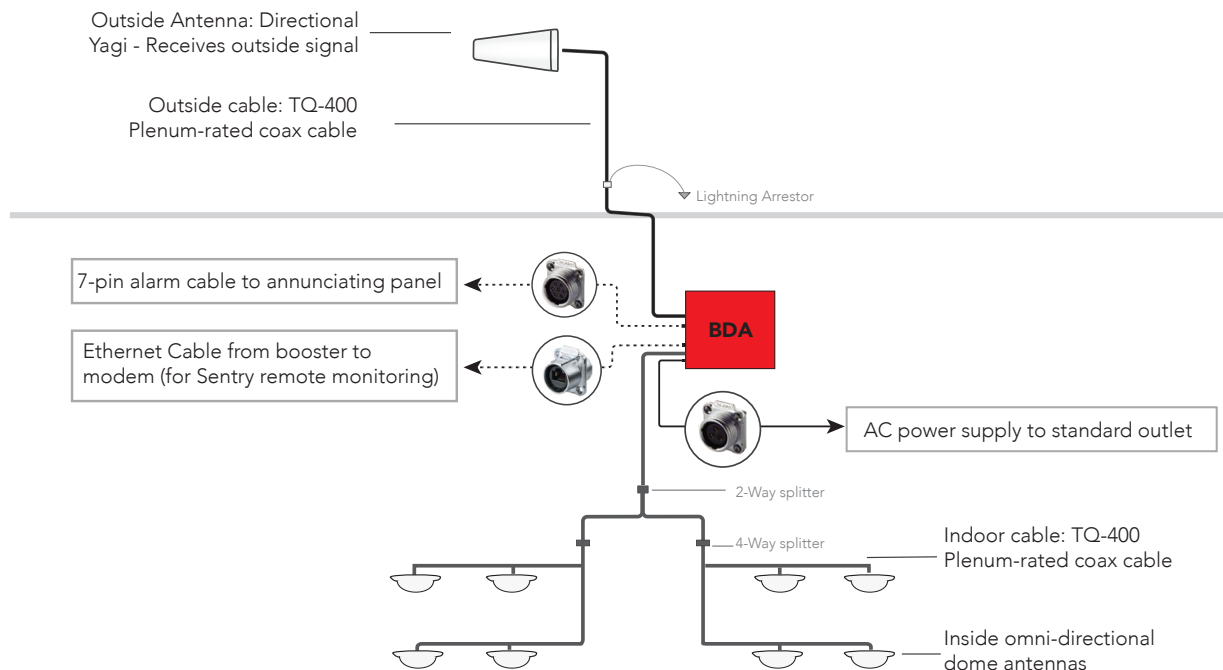



Guardian4 BDA Interface

Interface	Type	Description
A1	Grounding lug	Grounding lug
A2	OUTSIDE	N Female for OUTSIDE cable and antenna
A3	ALARM I/O	To Fire Department Control Box
A4	ETHERNET	Cat5e Standard Ethernet Cable Device
A5	POWER 110VAC	Connect to 110VAC or 110V of UPS output
A6	INSIDE	N Female for INSIDE cable and antenna
A7	USB	Used to initialize the network connection devices
A8	Alarm LEDs	Indicate an alarm condition
A9	DC 12-20V	Connect DC, voltage should be between 12-24V

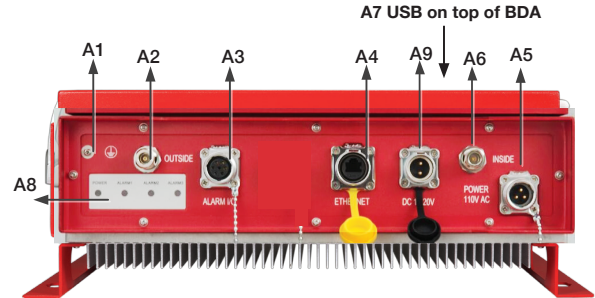

^a Outdoor Antenna Options

TQ-230W	Directional Wide Band 50 Ω Yagi Antenna (698 - 2700 MHz)	N-Female connectors	10 to 11 dBi
---------	--	---------------------	--------------

^b Inside Antenna Options

TQ-528W	Omni Wide Band Dome 50 Ω Antenna (698 - 2700 MHz)	N-Female connectors	3 to 4 dBi
TQ-248W	Directional Wide Band Panel 50 Ω Antenna (698-2700 MHz)	N-Female connectors	7 to 10 dBi

^c Splitters and Couplers

TQ-WS-2	Wide Band 2 Way Splitter
TQ-WS-4	Wide Band 4 Way Splitter

^d Plenum Cable

TQ-PL-1000	1000 ft, Ultra Low-Loss Coax Plenum Fire-Rated, Orange	Pool, no connectors
------------	--	---------------------

UL-rated for plenum ceilings (UL E473791)

Additional Required Components:

Note: Some component options are listed in table below. Not all accessories are listed.

- One External antenna ^a (directional Yagi)
- Multiple Inside antennas ^b (omnidirectional domes and/or directional panels)
- Cable splitter for inside antennas ^c
- Sufficient TQ-400 ultra-low loss interior/exterior cable, 50 ohm ^d
- Lightning protector
- Grounded surge suppressor for DC power supply

Ordering Information

Model	Description	Stock No.
Guardian4	80dB PublicSafety Band BDA Signal Booster	3996001

Included Components:

- Guardian4 bi-directional amplifier with NEMA-4 rated housing and mounting kit
- Alarm cable and connector
- Ethernet connector
- AC power cable
- DC power cable and connector

⚠ WARNING

THIS IS NOT A CONSUMER DEVICE. IT IS DESIGNED FOR INSTALLATION BY FCC LICENSEES AND QUALIFIED INSTALLERS. USERS MUST HAVE AN FCC LICENSE OR THE EXPRESS CONSENT OF AN FCC LICENSEE TO OPERATE THIS DEVICE. USERS MUST REGISTER CLASS B SIGNAL BOOSTERS (AS DEFINED BY 47 CFR 90.219) ONLINE AT: WWW.FCC.GOV/SIGNAL-BOOSTERS/REGISTRATION.

UNAUTHORIZED USE MAY RESULT IN SIGNIFICANT FORFEITURE PENALTIES, INCLUDING PENALTIES IN EXCESS OF \$100,000 FOR EACH CONTINUING VIOLATION.

Part 90 Signal Boosters. THIS IS A 90.219 CLASS B DEVICE.