

Features

- Isolator integrated into base
- Self restoring
- Red LED indication of short circuit
- Terminals accept 22 to 12 AWG wire sizes
- Supports Class A, Class X and Class B wiring
- Does not require SLC Loop address
- UUKL Listed for Smoke Control

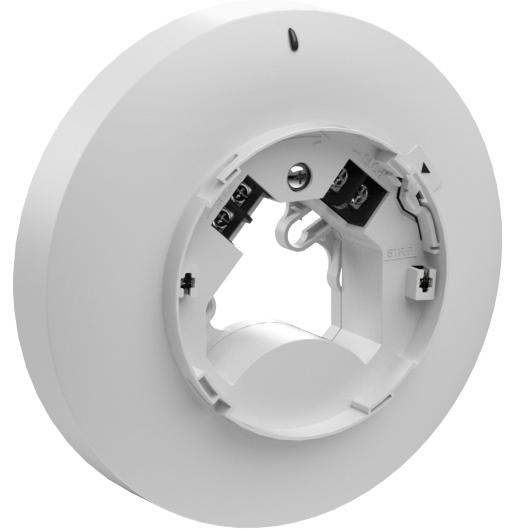

Description

The Isolator Base 6" (PAD300-IB) comes with an integrated isolator module included. The base has a locking feature for the detector that may be used or removed in the field. Once the head is removed, the isolator is accessible in the bottom of the unit.

The isolator will open the Signaling Line Circuit down stream when a short circuit is detected. This will provide devices between the control panel and the isolator to continue to operate. The short is indicated by a steady red LED and once the short is removed the unit will return to normal operation.

Technical Specifications

SLC Voltage	24 VDC
SLC Standby Current	300 μ A
Alarm LED Current	1.4mA
Installation Temperature Range	32°F to 150°F (0°C to 66°C)
Operating Humidity Range	< 93% (Non-condensing)
Dimensions	6.4 in (162 mm)
Weight	195 g (6.88 oz)
Height	1.57 in (40 mm)

Detector Base Mounting

PAD300-IB should be mounted directly on the electrical box. The mounting holes are configured for a single gang, 3-1/2" octagon, 3-1/2" square, double gang, 4" octagon, 4" square, 50mm c/c, 60mm c/c and 70mm c/c boxes. See Fig 1.

Fig. 1

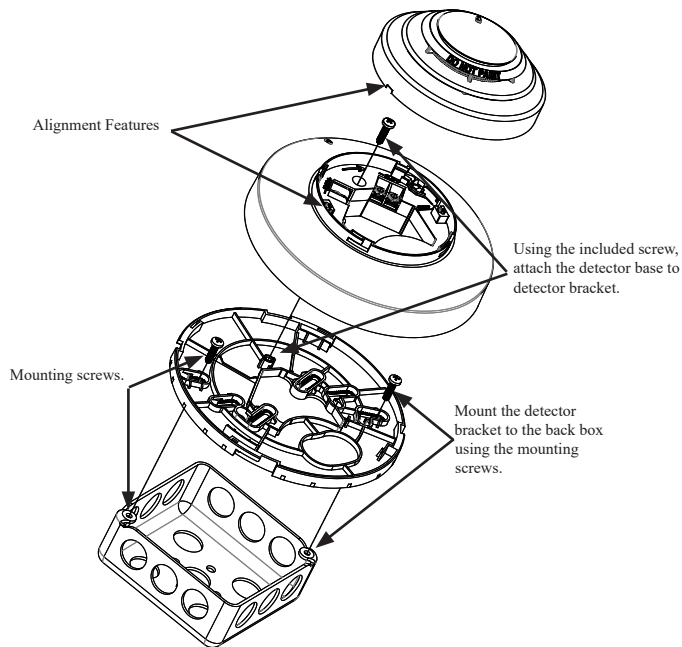

Locking Feature

Eliminate the Locking Feature

PAD300-IB include a locking feature that prevents removal of the detector and removal of the base cover without using a tool.

1. To enable this feature, break off the locking tab (refer to Figure 2), and then install the detector. See Fig. 2.

Fig. 2

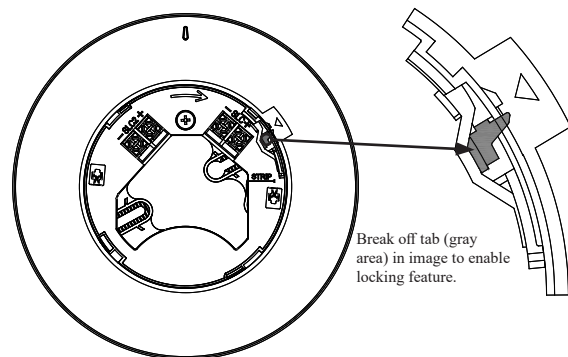

Removing of Detector Head from Base

2. To remove the detector from the base once the locking feature has been activated, insert a small screwdriver into the slot on the base to push the plastic tab while simultaneously turning the detector head counter-clockwise. See Fig. 3.

Fig. 3

Insert small screwdriver into slot to remove detector from base.

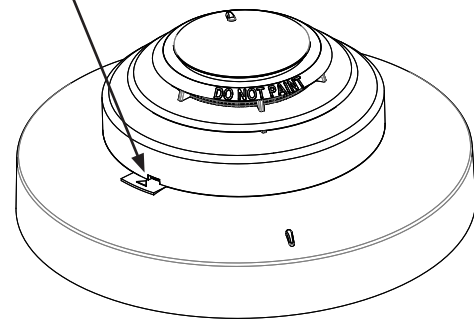

3. To remove the base cover from the lower enclosure once the locking feature has been activated, insert a small screwdriver into the slot on base to push the plastic tab while simultaneously turning the detector head counter-clockwise.

Ordering Information

Model	Description	Stock No.
PAD300-IB	Isolator Base	3992783