

End To End Optical Beam Smoke Detector

User Guide

EN

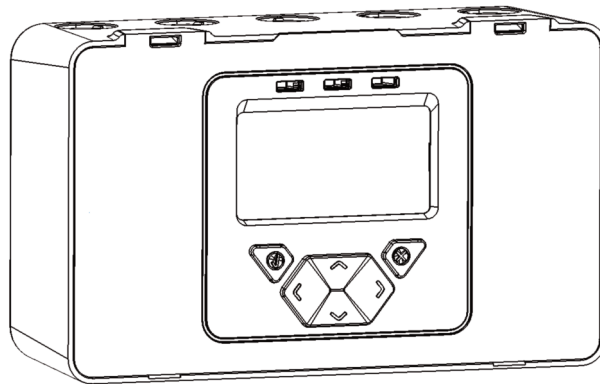
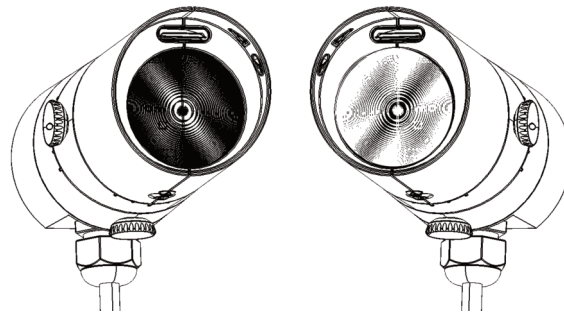

1. General Information

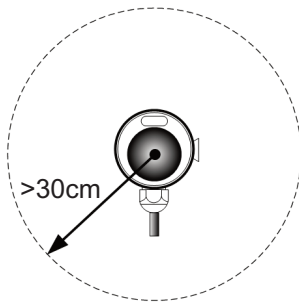

Ensure clear line of sight from Receiver to Transmitter

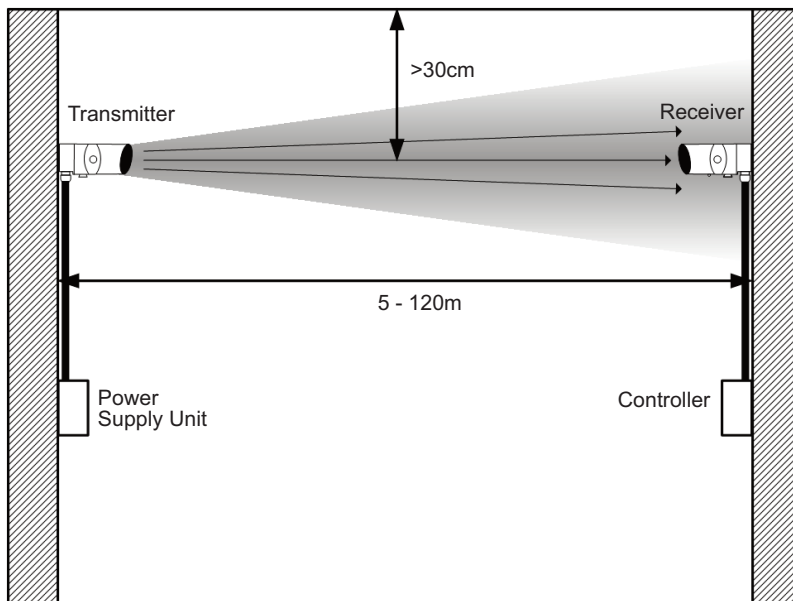

- **IMPORTANT NOTE: The infrared beam path MUST be kept clear of obstructions at all times! Failure to comply may result in the system initiating a Fire or Fault signal.**
- All installations should comply with local regulations
- For installations approved to UL 268 refer to NFPA 72 for installation guidance. In such installations, it is advised that the maximum distance of Transmitter and Receiver from the ceiling must be 10% of the distance between floor and ceiling
- Ensure a clear line of sight from Receiver to Transmitter
- Mount on solid surfaces (structural wall or girder) and ensure fixing is rigid
- Position beam as high as possible, but with a minimum distance of 30cm from Receiver/Transmitter to ceiling
- Mount Receiver and Transmitter directly opposite each other
- Do NOT position where personnel or objects can enter the beam path
- Do NOT install the Transmitter or Receiver in environments where condensation or icing are likely to occur

2. Wiring Diagrams

Wiring two Receivers onto two zones:

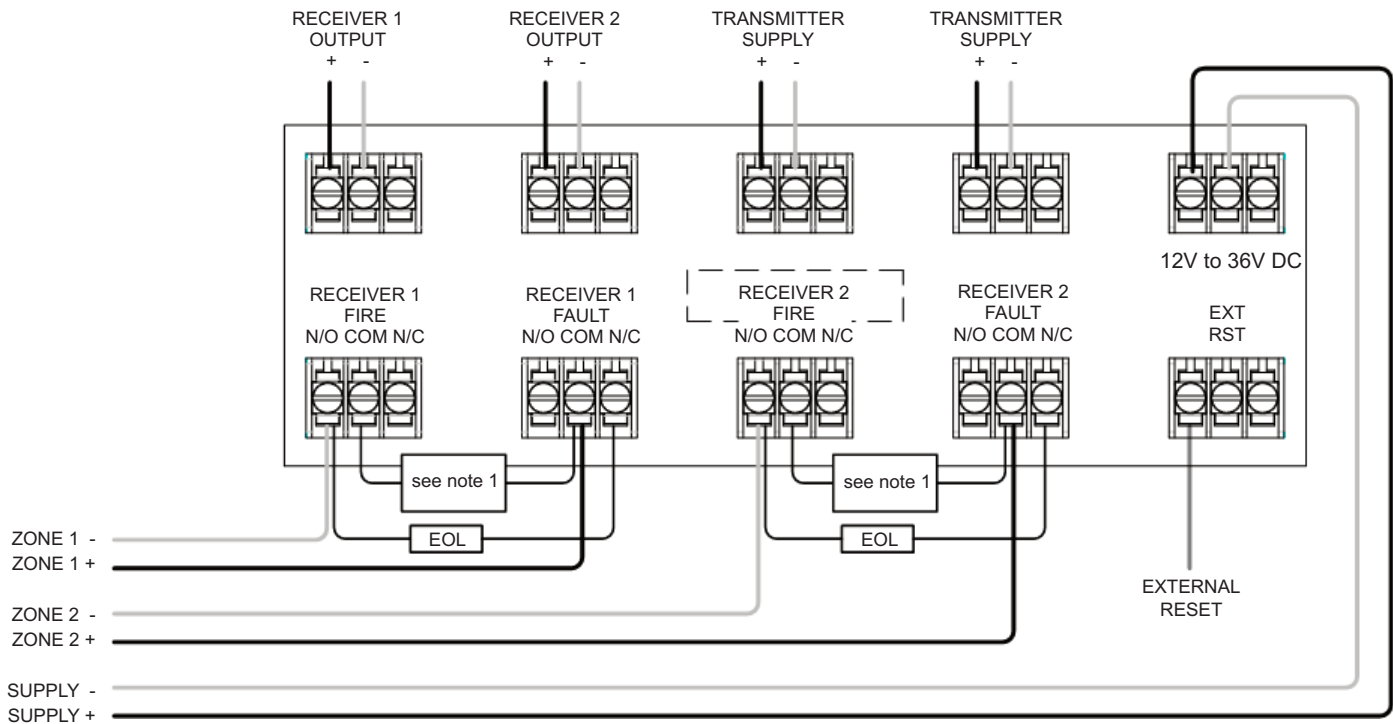

For connection of two Receivers to one zone:

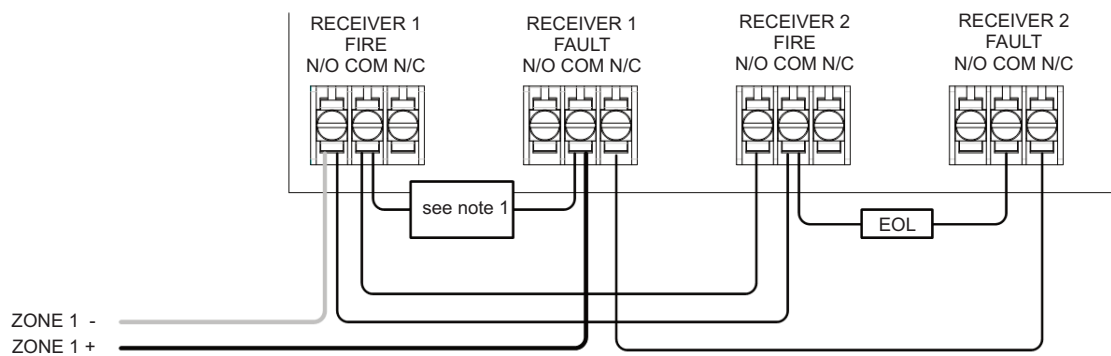

- Note 1: This component is the fire resistor. Its value is specified by the Fire Control Panel manufacturer. For U.S. installations it is typically a short circuit
- ALWAYS use a separate 2-core cable for each Receiver head
- CAUTION: For system monitoring - Do not use looped wire under any terminals. Break wire run to provide monitoring of connections
- Components not supplied:
 - End Of Line ('EOL') component - supplied by Fire Control Panel manufacturer
 - Fire Resistor
- After installation, check operation of Fire and Fault connection on Fire Panel
- Apply a voltage of 5V to 40V to 'EXT RST' contact for at least 2 seconds to clear a latched fire condition
- For wiring to other types of Fire Control Panel, or to wire multiple Controllers onto one Zone, refer to additional installation instructions supplied with the product

3. Fitting the Product

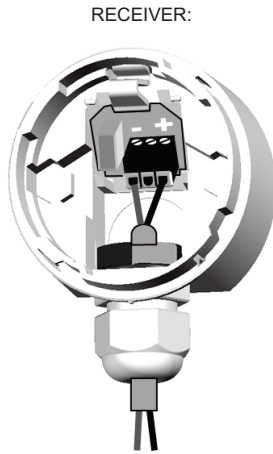
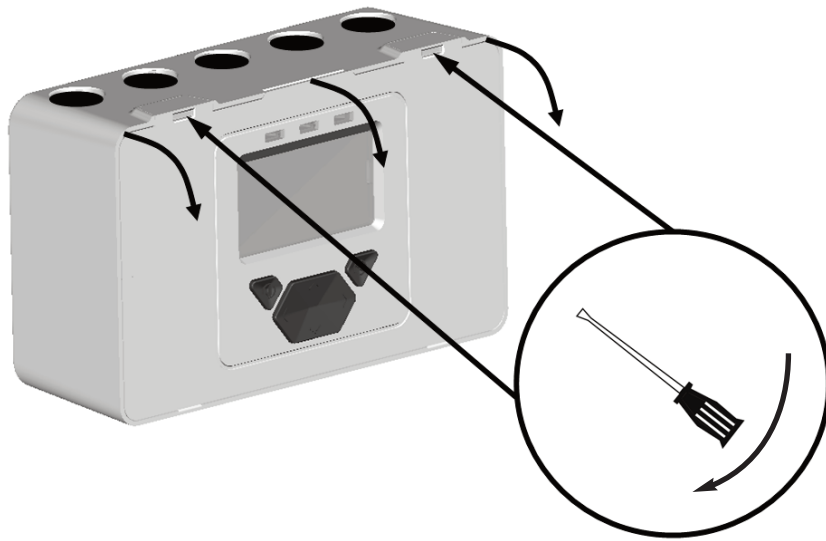

- +
TO 'RECEIVER
OUTPUT' ON
CONTROLLER
BOARD

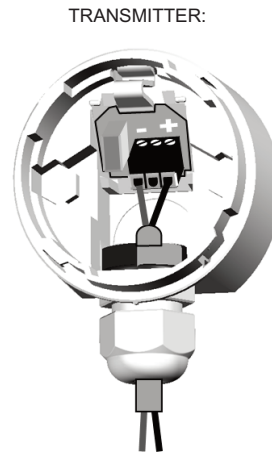

- +
TO
12 to 36V SUPPLY OR
'TRANSMITTER SUPPLY'
ON CONTROLLER
BOARD

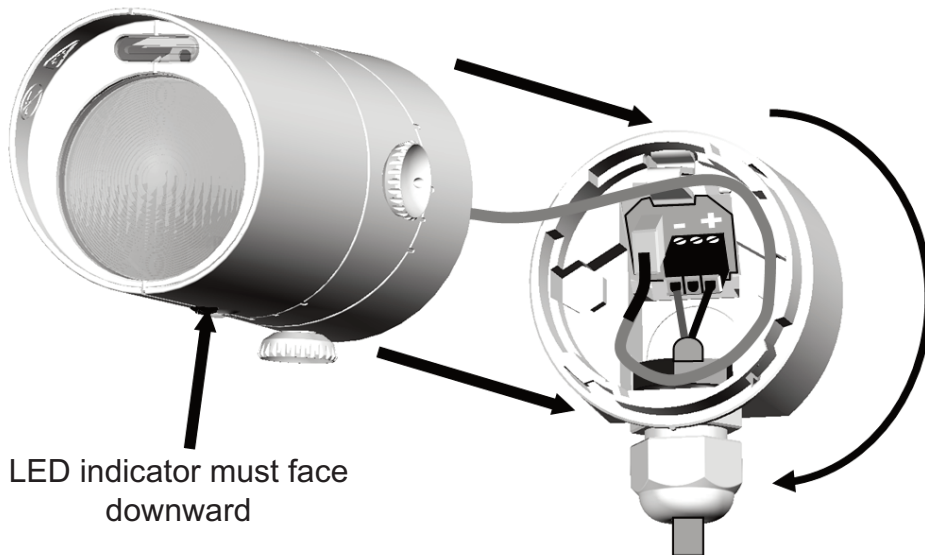

LED indicator must face
downward

4. Apply Power

NOTE: One System Controller can be used to control and monitor up to two Receiver heads. The '#' symbol in this guide is used to represent the number of the Receiver currently selected (1 or 2).

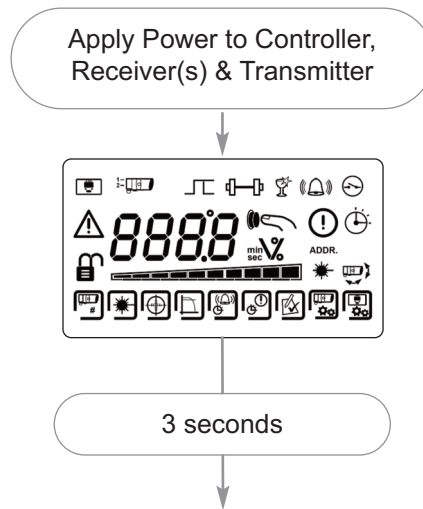

- Receivers are not found (normal at this stage):

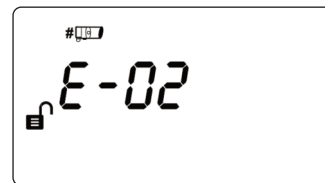

- Commissioned System:

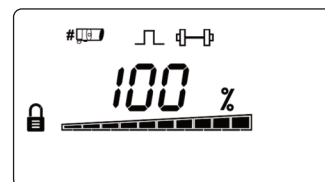

- Receivers have been found but not commissioned:

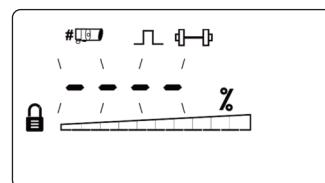

- Communications fault, or no Receiver connected:

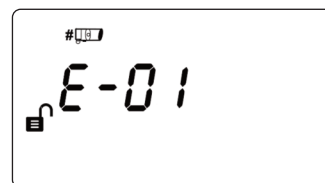

5. Enter Pass Code to Access Engineering Menu

Press ✓ to enter PASS CODE SCREEN in USER MENU

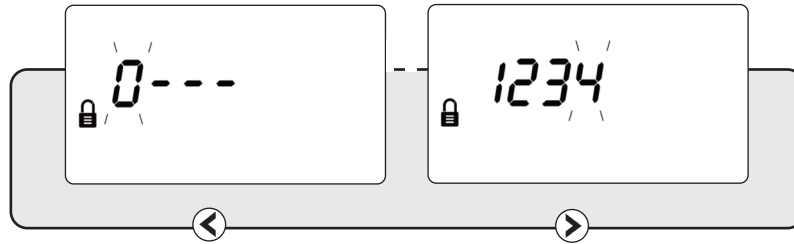

Default Pass Code: 1 2 3 4

- ⬆ ⬇ Change digit
- ⬅ ➡ Move between digits
- ✓ Accept

- An incorrect Pass Code will return the display to the Pass Code entry screen
- Three incorrect attempts will lock access for three minutes

6. Finding Receivers

- Perform 'Find' during initial installation, or when adding or removing Receivers

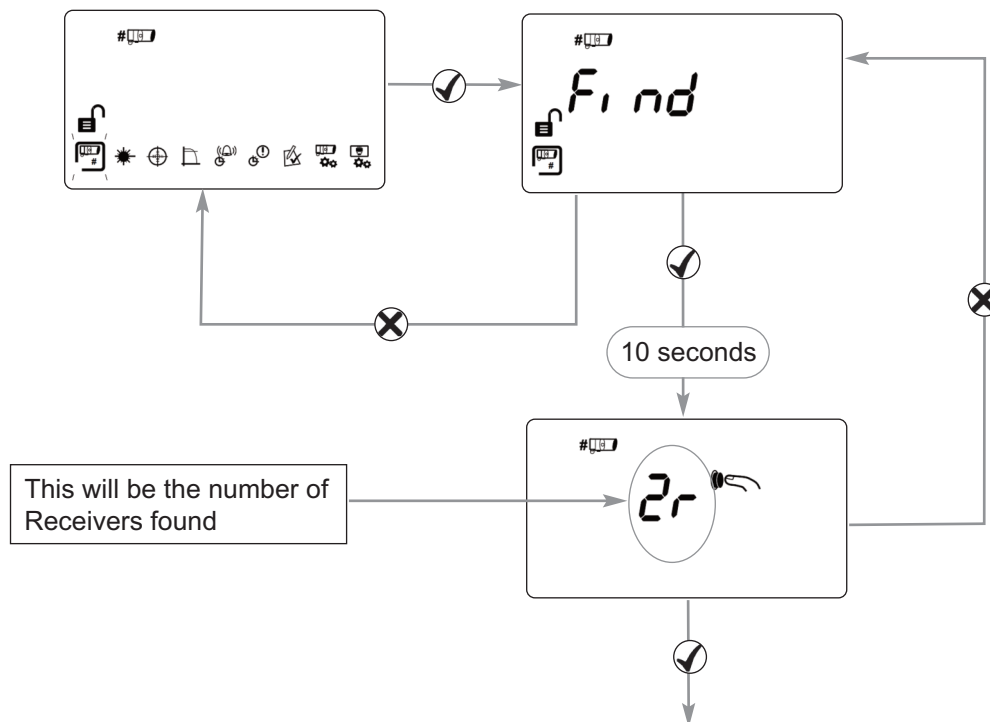

- Press ✓ to enable 'Found' Receivers
- Any unused Receiver channels are switched off
- Press ✗ to re-scan if the number is incorrect

7. Select Receiver to be Accessed

- All Receivers need to be aligned separately
- Steps 8 and 9 explain how to align individual Receivers

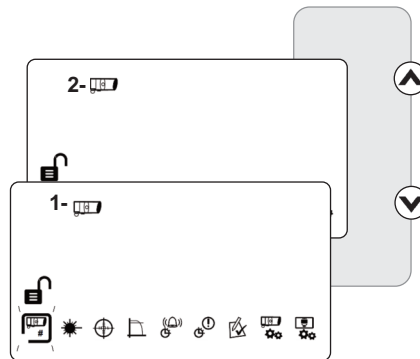

8. LASER Targeting

- The LASER in the Receiver head is used to align the Receiver with the Transmitter.
- The LASER can be activated using the button on the Receiver head whilst in Engineering Menu, or via the LASER icon in the ENGINEERING MENU as shown below.
- Move the LASER as close to the Transmitter as possible, by moving the Receiver's thumbwheels
- The system will signal Fault while in this mode

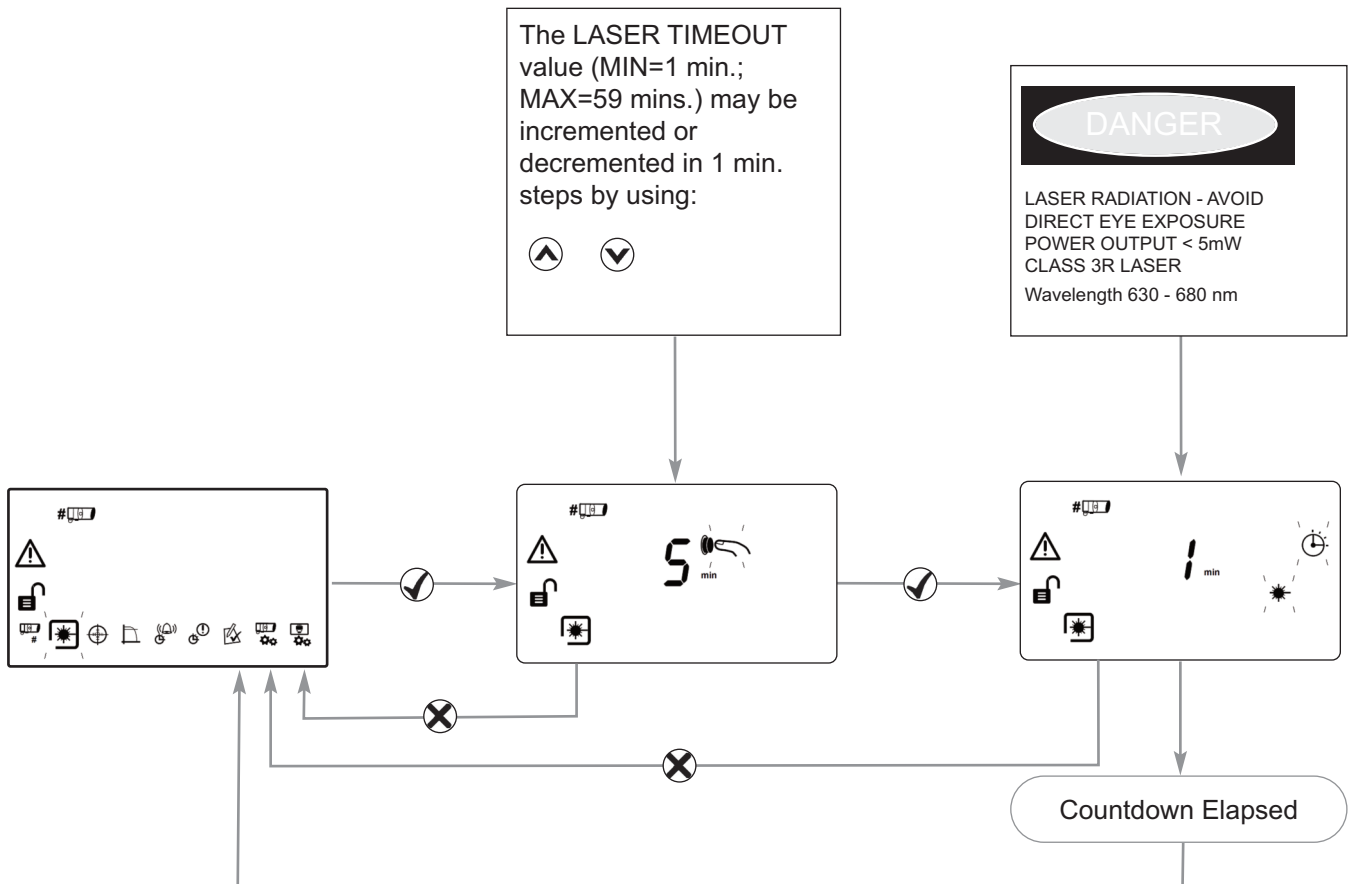

If it is not possible to see the LASER because of the installation environment (for example, if there is high ambient light) then align the Receiver by eye so that it is pointing at the Transmitter.

9. Alignment

Step 1

In installation mode you are centring the Transmitter beam onto the Receiver and the system is adjusting its power for optimum signal.

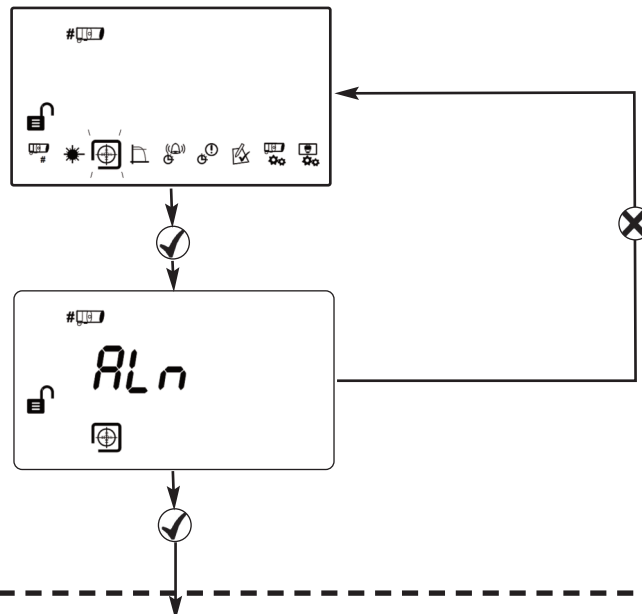

Step 2

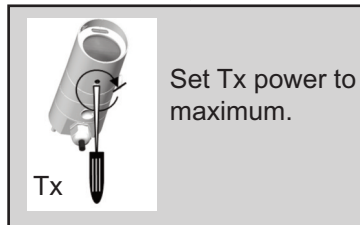

NOTE 1: Value can be between 2 and 178. A higher value means a better alignment.

Step 3

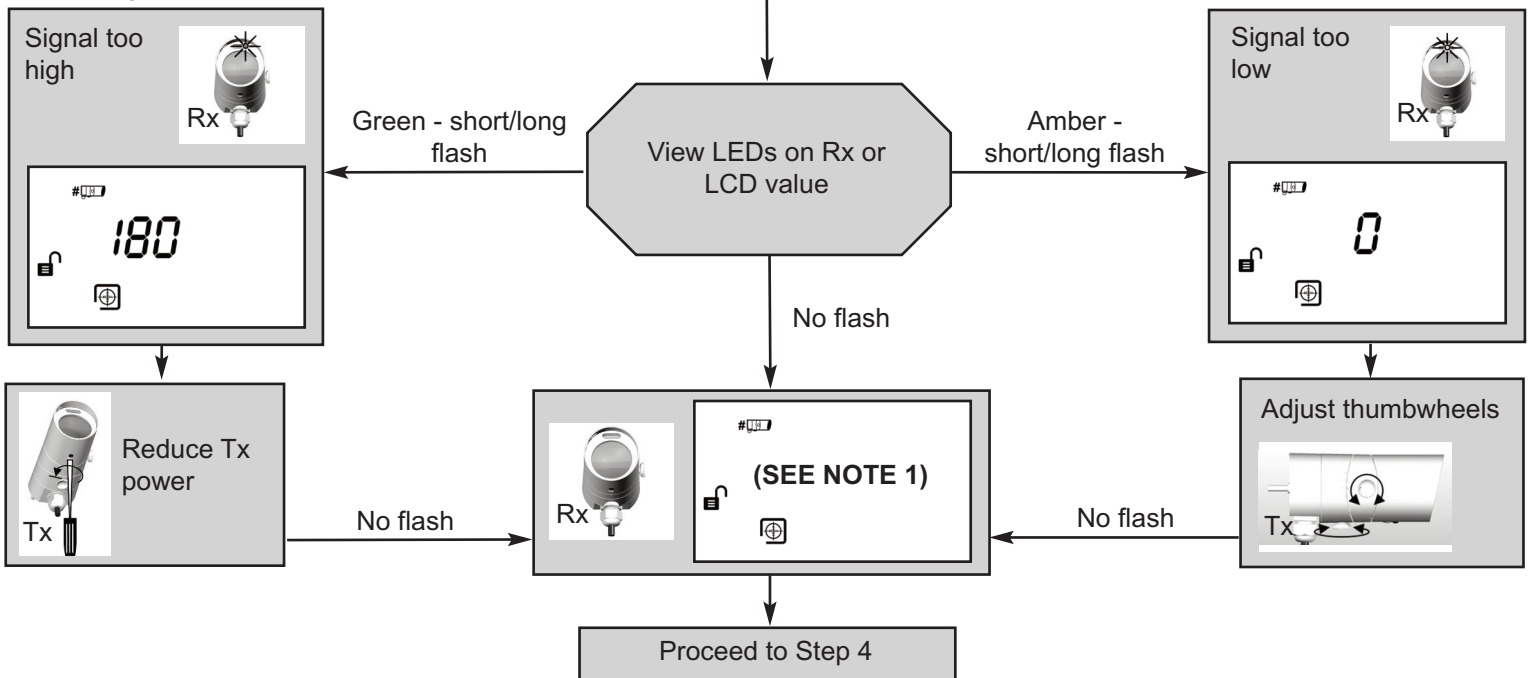

Step 4

From Step 3

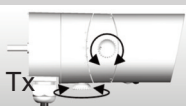

Adjust one thumbwheel by 1/4 turn.

NOTE 1: Value can be between 2 and 178. A higher value means a better alignment.

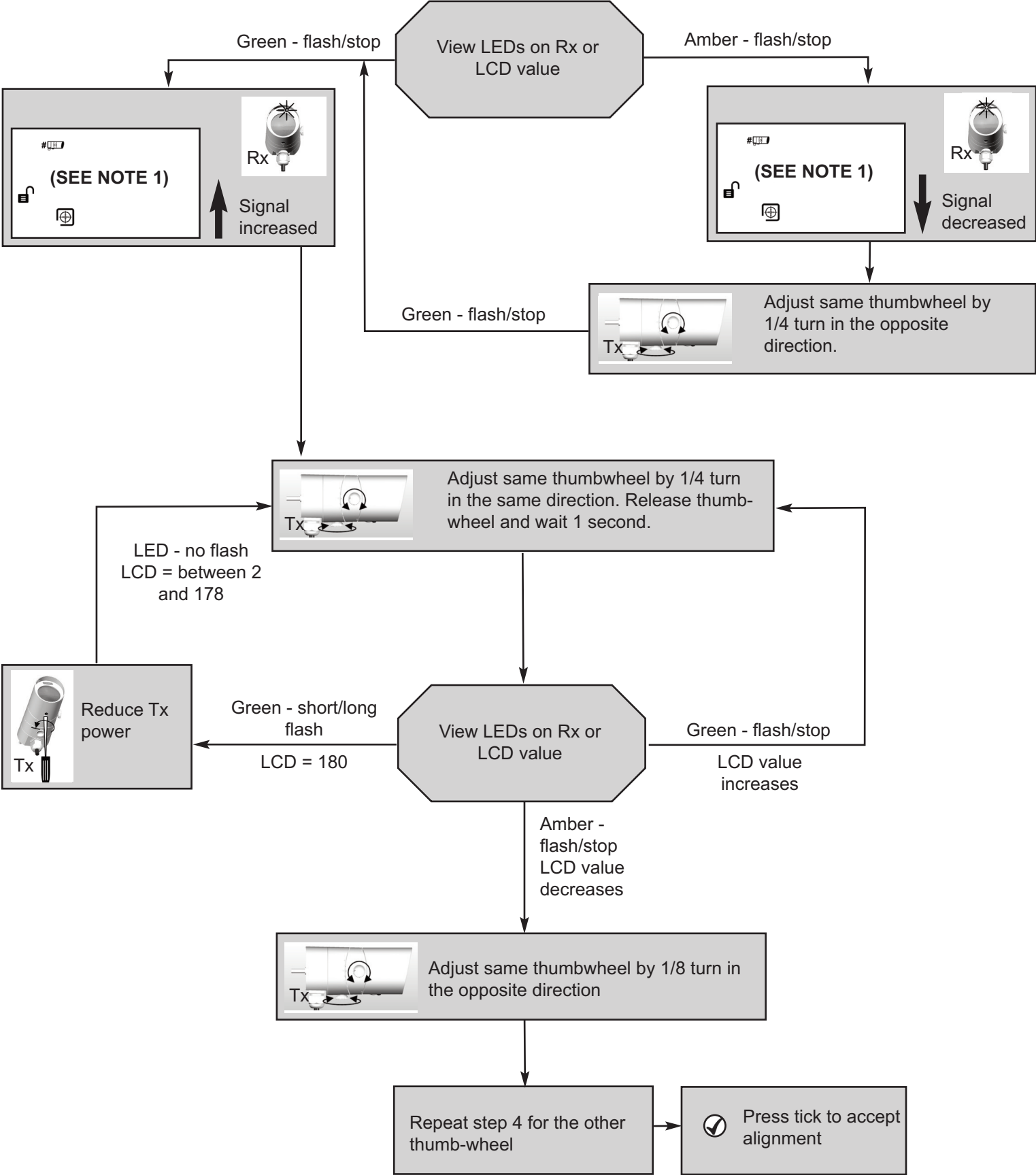

10. Manual Fire and Fault Tests

After installation or cleaning, it is recommended that a Manual Fire and Fault test is performed:

Fire Test: Slowly half-cover the Receiver. The Controller will indicate Fire after the Fire Delay Time.

Uncover the Receiver. The Controller will return to Normal state after approximately 5 seconds.

Fault Test: Completely cover the Receiver taking less than 2 seconds to do so. The Controller will indicate Fault after the Fault Delay time.

Uncover the Receiver. The Controller will return to Normal state after approximately 5 seconds.

11. Remote Fire Test

The Remote Fire Test allows the user to perform a Fire Test from the System Controller.

The Remote Fire Test is acceptable for Fire Authority Acceptance and Routine Maintenance per UL 268-5.

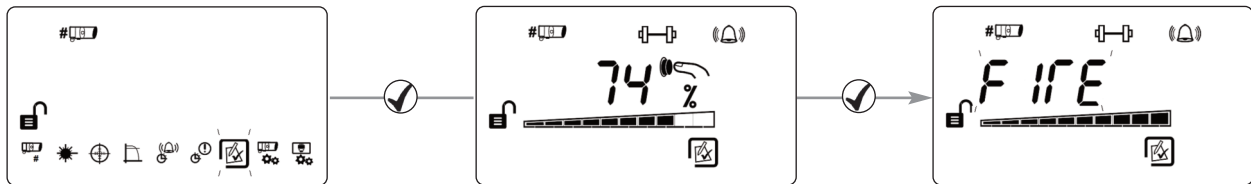

Receiver Fire LED Test

The Receiver will signal 'Fire', the System Controller will stay Normal.

Press **X** to exit without performing the test.

Relay / Controller Wiring Test

The System Controller signals 'Fire' to the Fire Control Panel. Press **✓** or **X** to exit.

12. Fire Threshold

This setting is the threshold at which the Receiver will detect a fire. Default factory setting=35%. (Set for each Receiver).

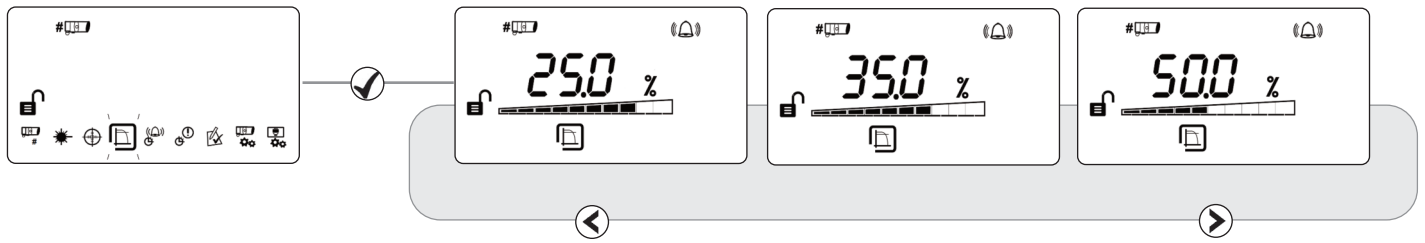

- Sensitivity can be adjusted in 1% steps by pressing up or down keys
- Press ✓ to accept setting

UL268 Fire Threshold Ranges:

Distance between Transmitter and Receiver	Fire Threshold Range
5 - 10m (16.4 - 32.8 ft)	25%
10 - 20m (32.8 - 65.6 ft)	25 - 30%
20 - 40m (65.6 - 131.2 ft)	25 - 45%
40 - 60m (131.2 - 196.8 ft)	35 - 60%
60 - 80m (196.8 - 262.5 ft)	45 - 60%
80 - 100m (262.5 - 328.1 ft)	55 - 60%
100 - 120m (328.1 - 393.7 ft)	60 %

EN Approved Sensitivity Ranges:

Complies with EN54-12 for sensitivity levels between 25% and 35%, with a maximum delay to fire of 20 seconds

13. Delay To Fire

This setting is the delay the System Controller uses before signalling a FIRE condition to the Fire Control Panel. Default factory setting=10 seconds.

(Set for each Receiver).

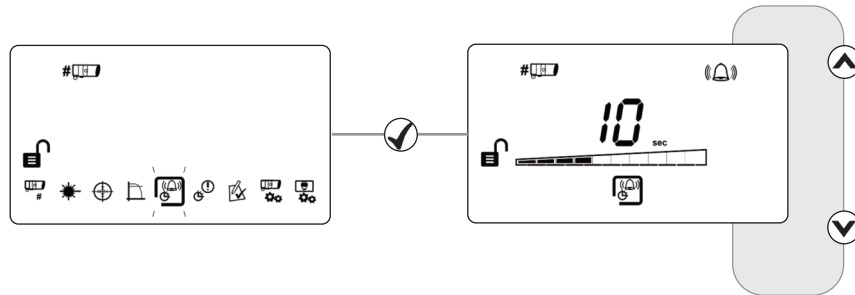

14. Delay To Fault

This setting is the delay the System Controller uses before signalling a FAULT condition to the Fire Control Panel. Default factory setting=10 seconds.

(Set for each Receiver).

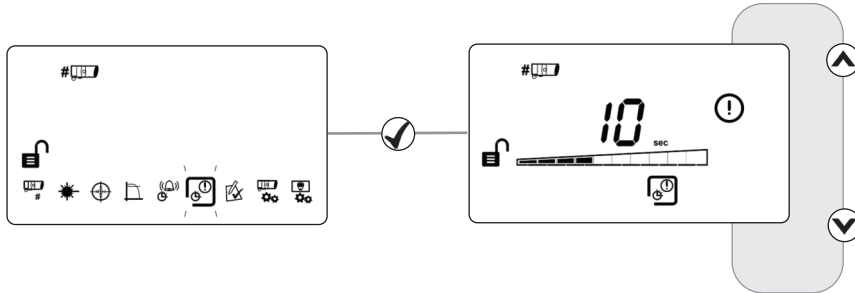

15. Latching/Non-Latching Mode

In Latching Mode the system will stay in Fire condition after the fire clears. In Non-Latching Mode the system will automatically return to normal condition after the fire clears

Default factory setting=Non-Latching (Set for each Receiver).

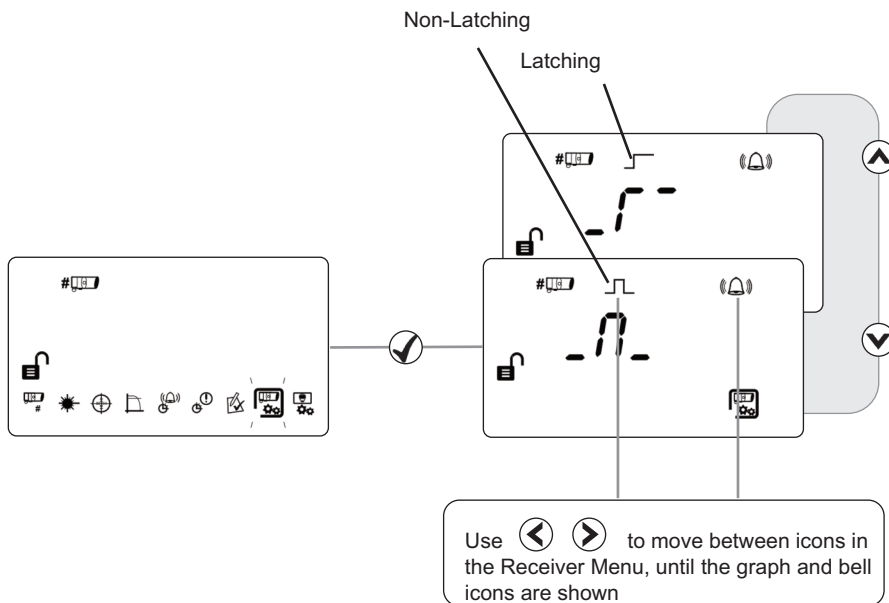

To clear a latched fire, apply 5-40V to the External Reset terminal, enter the passcode, or power cycle for 20s.

16. Cleaning The System

The system will automatically compensate for dust build-up by changing the Compensation Level. However, it is recommended that the Receiver lenses are cleaned periodically with a soft lint-free cloth.

The system should be isolated from the Fire Control Panel before cleaning takes place. After cleaning, verify that the system is operating normally by following the Alignment procedure and the Fire and Fault Tests described in this User Guide.

17. Troubleshooting

E-00	AIM not recognised	Refer to manufacturer for further technical assistance
E-01	Receiver Communications Fault	Check wiring between Controller and Receiver
E-02	'Find' not successfully executed	Follow 'Find' process
E-03	Compensation limit reached	Clean and re-align system
E-04	Receiver missed too many readings, or lost sync with the Transmitter	Ensure clear line of sight from Transmitter to Receiver
E-05	Receiver is not aligned	Follow alignment procedure
E-06	Rapid Obscuration Fault	Ensure clear line of sight from Transmitter to Receiver
E-07	Signal High Fault	Ensure there is no stray light from another source
E-15	Signal too low at end of alignment	Ensure clear line of sight from Transmitter to Receiver. Ensure alignment of Transmitter AND Receiver. Do not exit whilst alignment status LEDs are still flashing
E-16	Signal too high at end of alignment	Follow alignment procedure again. Do not exit whilst alignment status LEDs are still flashing
E-18	Short circuit detected on communications between Controller and Receiver	Check wiring between Controller and Receiver
E-19	IR signal integrity fault	Check there are no strong sources of light near the Receiver, or direct sunlight
E-20	Ambient light fault	Check there are no strong sources of light near the Receiver, or direct sunlight
E-21	Power too low fault	Check power supply to Controller

18. Technical Specifications

Parameter	Value
Operating Distance between Transmitter and Receiver	5 - 120m
Operating Voltage Range	12 to 36V DC +/- 10%
Transmitter Current	8mA
Quiescent Current (Controller with 1 or 2 Receivers)	14mA
Alarm Current (Controller with 1 or 2 Receivers)	14mA
Fault Current (Controller with 1 or 2 Receivers)	14mA
Power Down Reset Time	>20 seconds
Fire and Fault Relay Contacts	VFCO 2A@ 30 Volts DC, resistive
Maximum Cable Length (Controller to Receiver)	100m
Cable Gauge	24 - 14 AWG 0.5 - 1.6mm
Operating Temperature	-10°C to +55°C (non-condensing)- EN -20°C to +55°C (non-condensing)- UL
Storage Temperature	-40°C to +85°C (non-condensing)
Receiver Tolerance to Beam Misalignment at 25% sensitivity	± 2.5°
Transmitter Tolerance to Beam Misalignment at 25% sensitivity	± 0.7°
Fire Threshold Range	0.45 - 3.98 dB 10 - 60%
Delays to Fire and Fault	2-30s, individually selectable
Optical Wavelength	850nm
Rapid Obscuration Fault Threshold	85%
LED Indications - Control Unit	Red = Fire (one for each Receiver) Amber = Fault (one for each Receiver) Green = System OK
LED Indications - Receiver	Red = Fire. Green and Amber indication LEDs for single-person alignment
IP Rating	IP54
Relative Humidity (Max.)	93%, (non-condensing)
CPD Reference	0786-CPD-21162
UL File	S3417 (volume 6)
Housing Construction (Controller/Transmitter/Receiver)	UL94 V0 PC

Dimensions	Width, mm (in)	Height, mm (in)	Depth, mm (in)	Weight, kg (lb)
Control Unit	202.7 (7.98)	124 (4.9)	71.5 (2.82)	0.606 (1.34)
Transmitter & Receiver	77.6 (3.05)	77.6 (3.05)	160 (6.3)	0.207 (0.46) inc. brackets

End To End Optical Beam Smoke Detector

Additional Information

EN

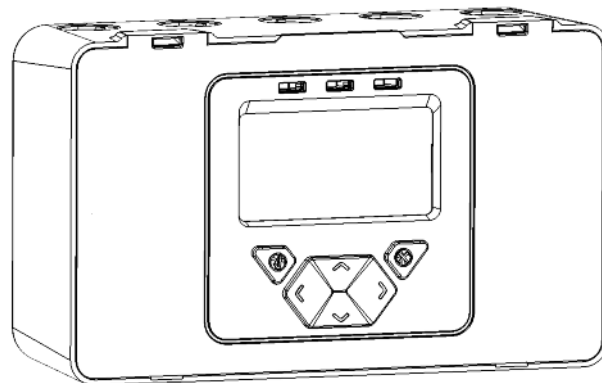
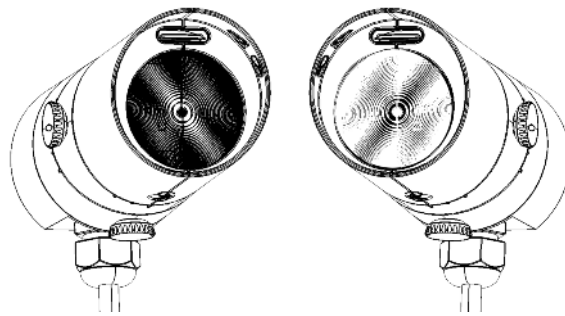

1. Multiple Zone Wiring

When using more than one System Controller on a single zone of a conventional Fire Control Panel (FCP), it is important to choose the correct method of wiring. Incorrect wiring may result in a Controller isolating subsequent devices on that zone if it enters a Fault condition, and may prevent these subsequent devices signalling a Fire condition back to the FCP.

If the FCP monitors for point detector removal, it is possible to use the following wiring diagrams which use diodes to provide zone continuity in the event of a Fault state on any Controller.

Two Receivers connected to Controller:

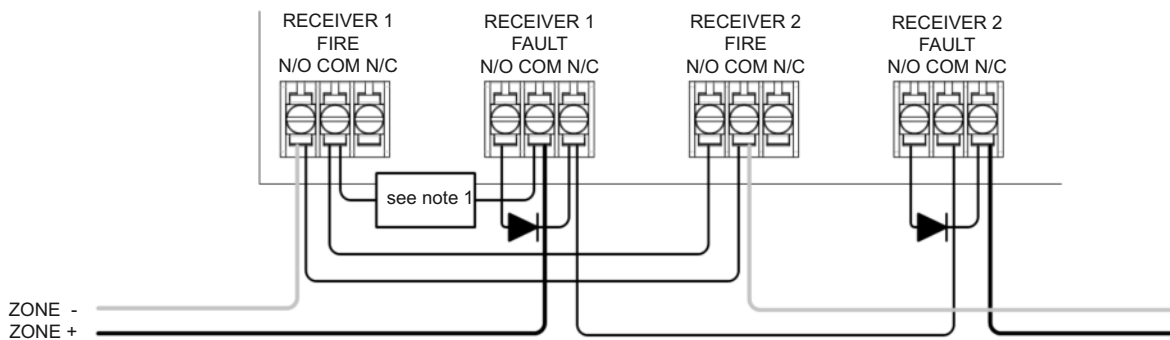

Single Receiver connected to Controller on "Receiver 1":

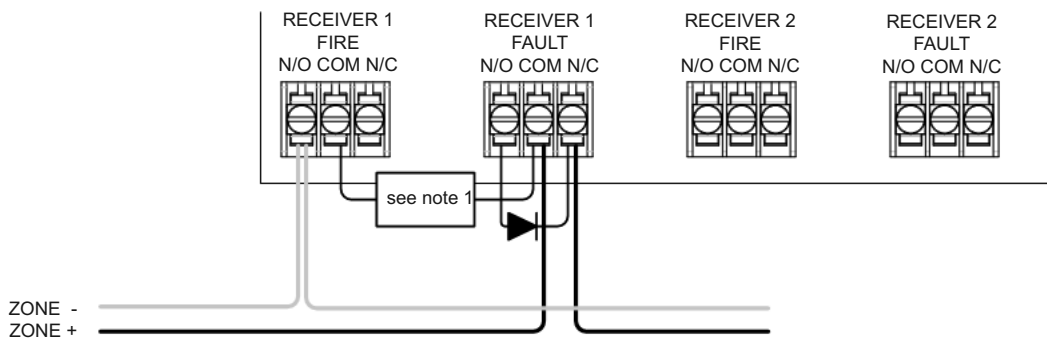

Note 1 - This component is the Fire Resistor. Its value is specified by the FCP manufacturer, and is not supplied with the System Controller. For U.S. installations it is typically a short circuit.

Note 2 - Recommended diode type: Schottky, 60Volt, 1Amp; must be UL listed for installations meeting NFPA72.

1. Multiple Zone Wiring (continued)

If the FCP does not monitor for detector removal, it is recommended that the following wiring diagram be used. For installations conforming to UL268 and NFPA72, the following diagram MUST be used when wiring multiple Controllers onto one zone.

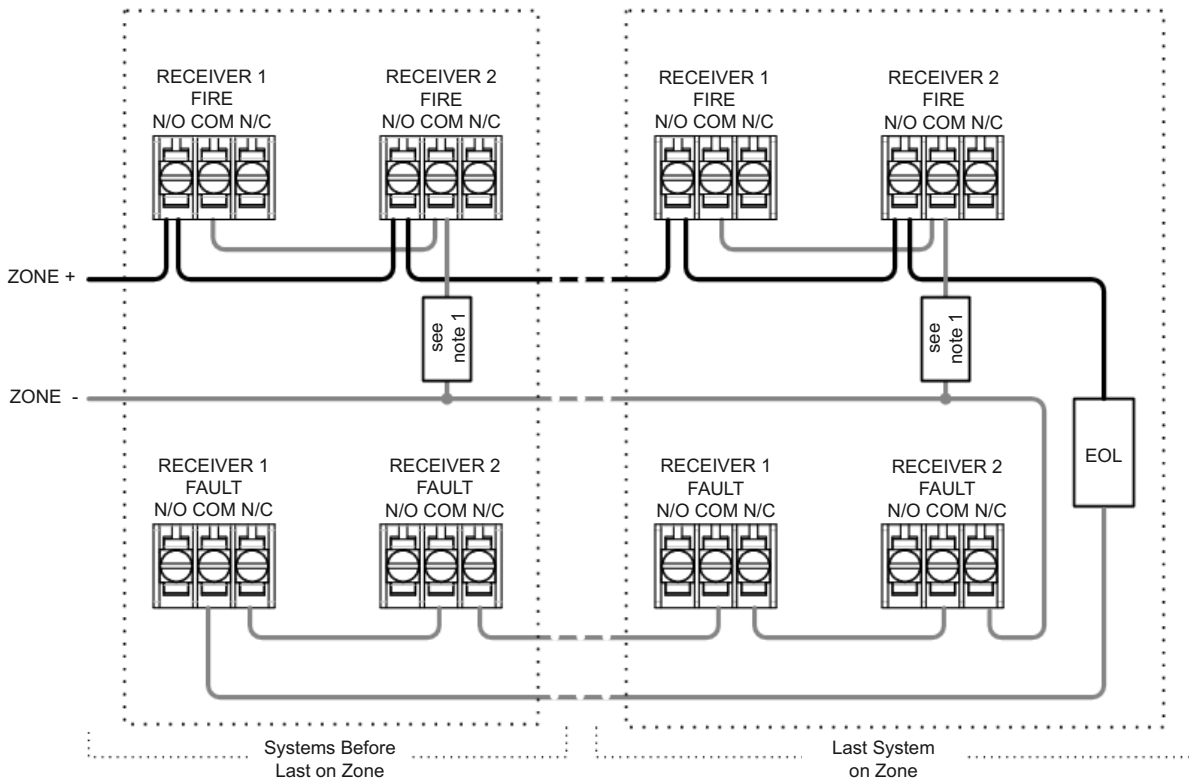

Note 1 - This component is the Fire Resistor. Its value is specified by the FCP manufacturer, and is not supplied with the System Controller. For U.S. installations it is typically a short circuit.

EOL - End of Line component. This is supplied with the FCP, and not supplied with the System Controller.

Do NOT wire to any unused relay pairs.

2. Display and Indicators

2.1 LCD Icon Layout

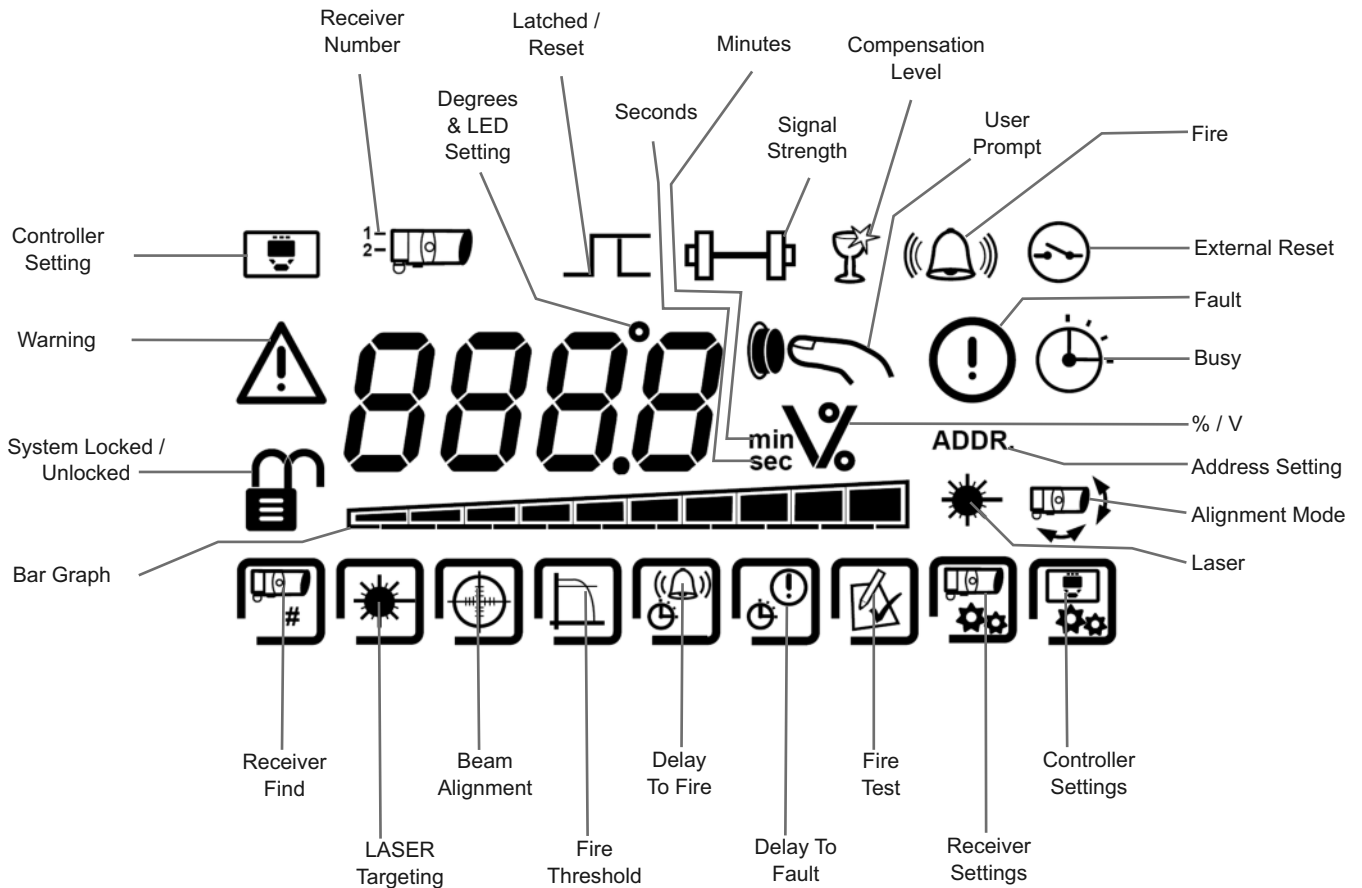

2.2 Receiver Status Indicators

The Green and Amber LEDs flash during alignment to indicate alignment status. Refer to alignment procedure for further information.

The Red LED will flash every 10 seconds when a fire is detected during normal operation.

2.3 Controller Status Indicators

Condition	(LEFT HAND LED) RECEIVER 1 STATUS LED	(MIDDLE LED) RECEIVER 2 STATUS LED	FIRE RELAY STATE	FAULT RELAY STATE
Normal	No Flash	No Flash	Open	Closed
Fault (Trouble)	Flashes AMBER every 10 seconds	Flashes AMBER every 10 seconds	Open	Open
Fire (Alarm)	Flashes RED every 10 seconds	Flashes RED every 10 seconds	Closed	Closed

System Controller Status LED (Right-hand LED) flashes green every 10 seconds.

3. User Menu

3.1 User Menu Overview

The USER MENU allows system settings to be viewed only.

The USER MENU will timeout 15 minutes after the last key press.

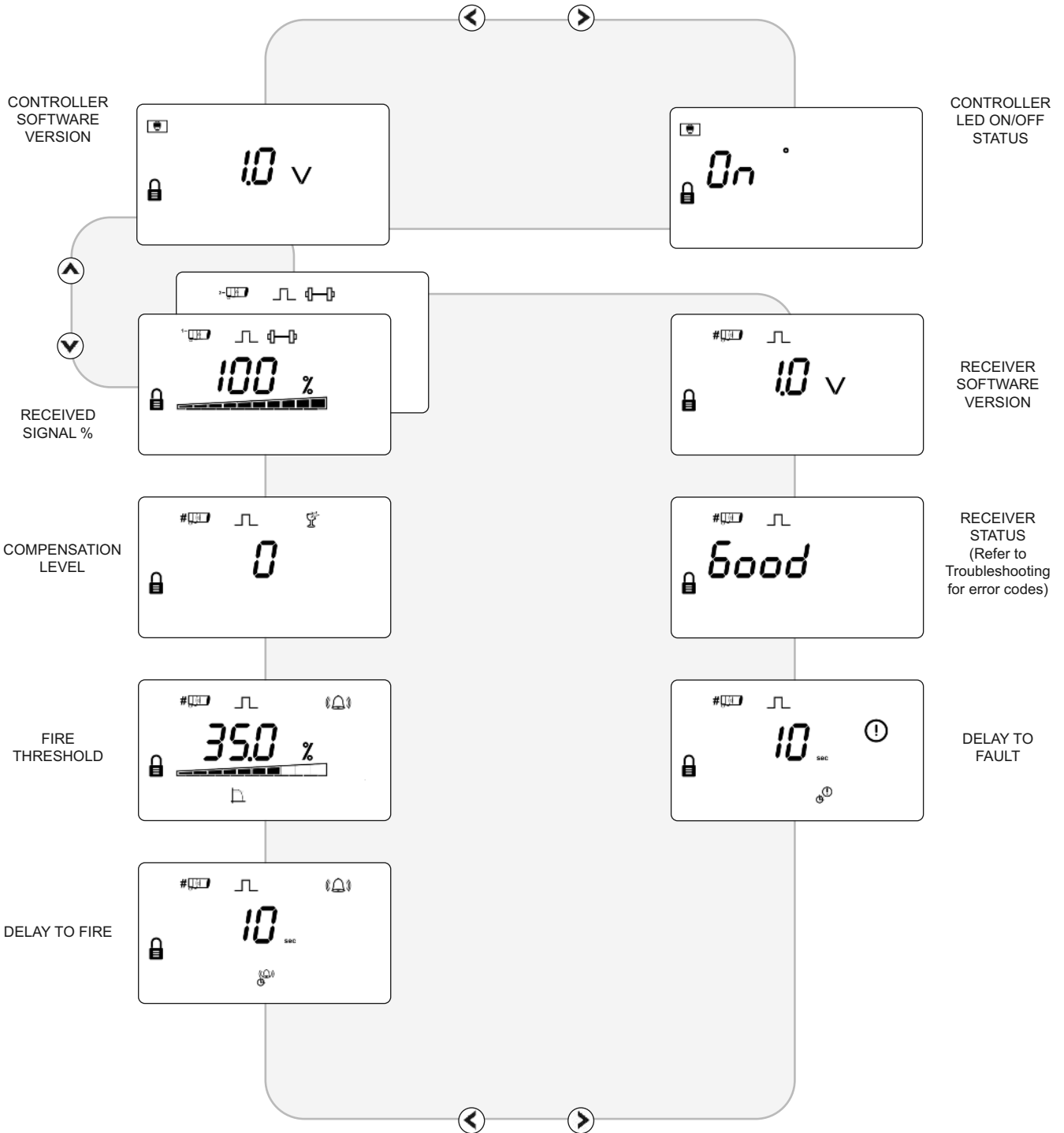

4. Engineering Menu

4.1 Engineering Menu Overview

The ENGINEERING MENU allows system settings to be changed.

The ENGINEERING MENU will timeout 60 minutes after the last key press.

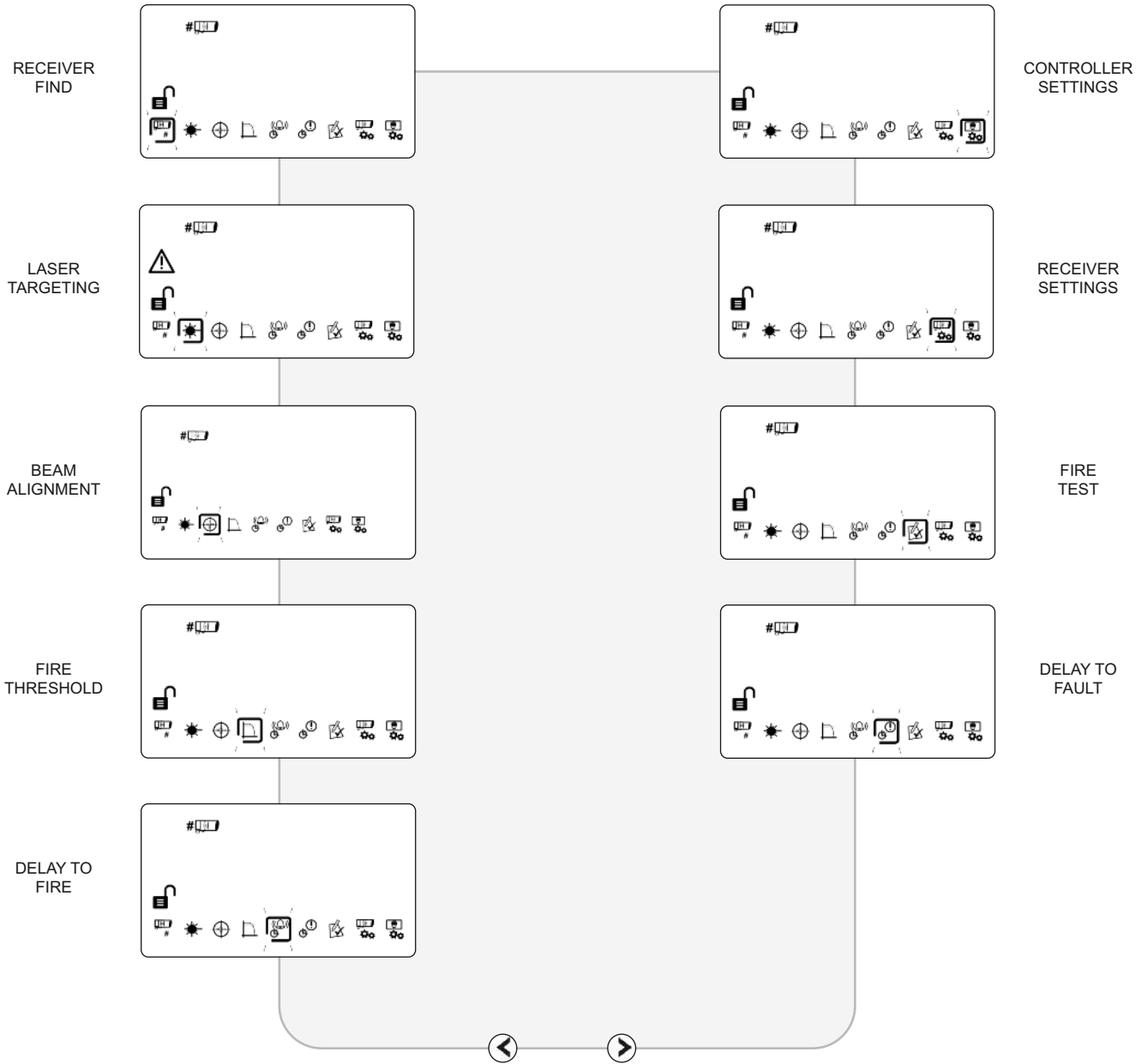

4.2 Receiver Settings

4.2.1 Receiver Settings Overview

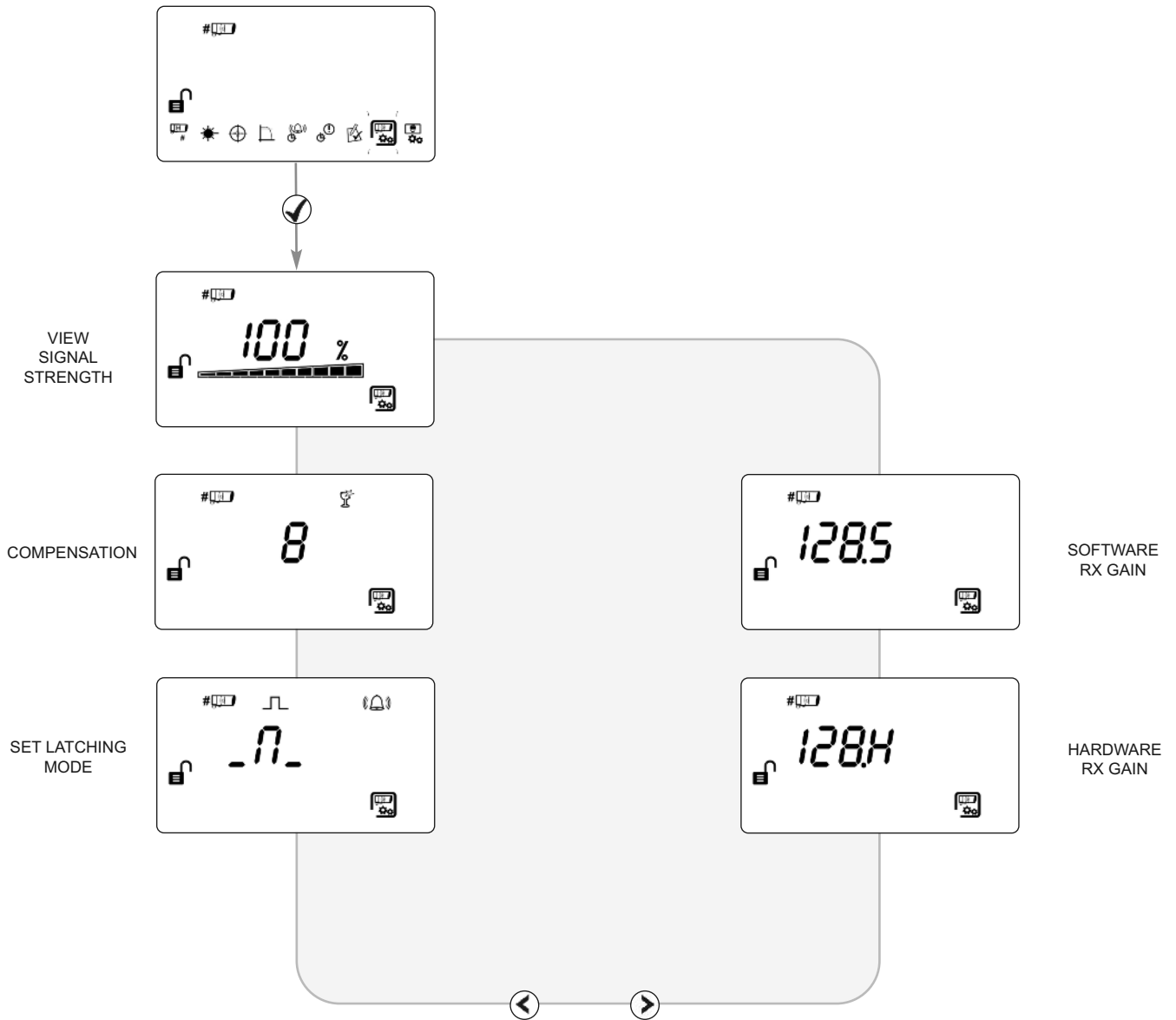

4.3 Controller Settings

4.3.1 Controller Settings Overview

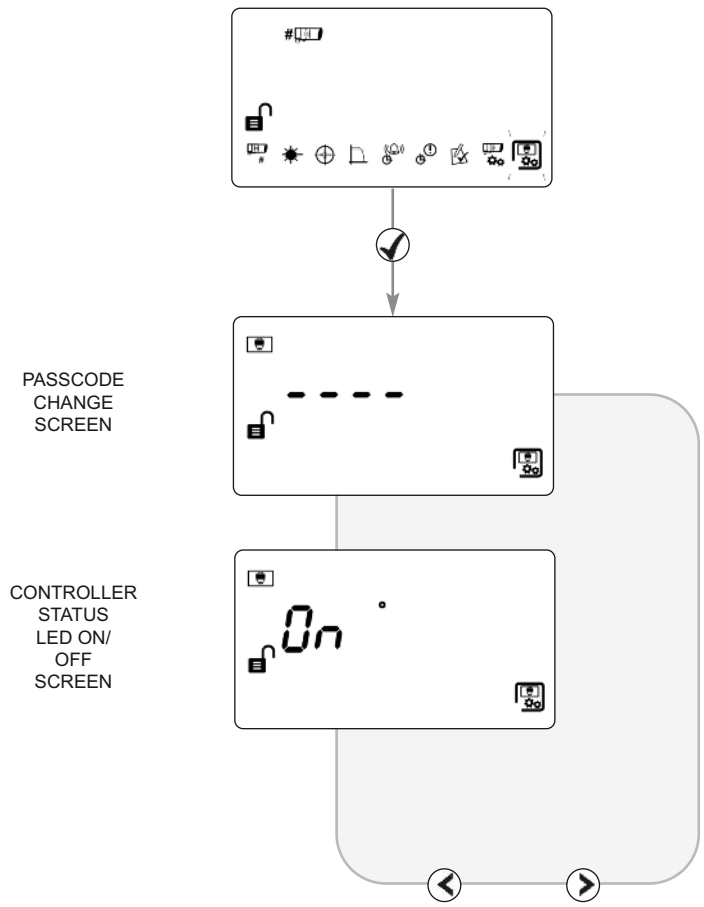

4.3.2 Passcode Change Screen

- This screen allows the user to change the Pass Code used to access the ENGINEERING MENU.

NOTE: The number being altered flashes. A partial passcode (ie. with dashes in it) will not be accepted.

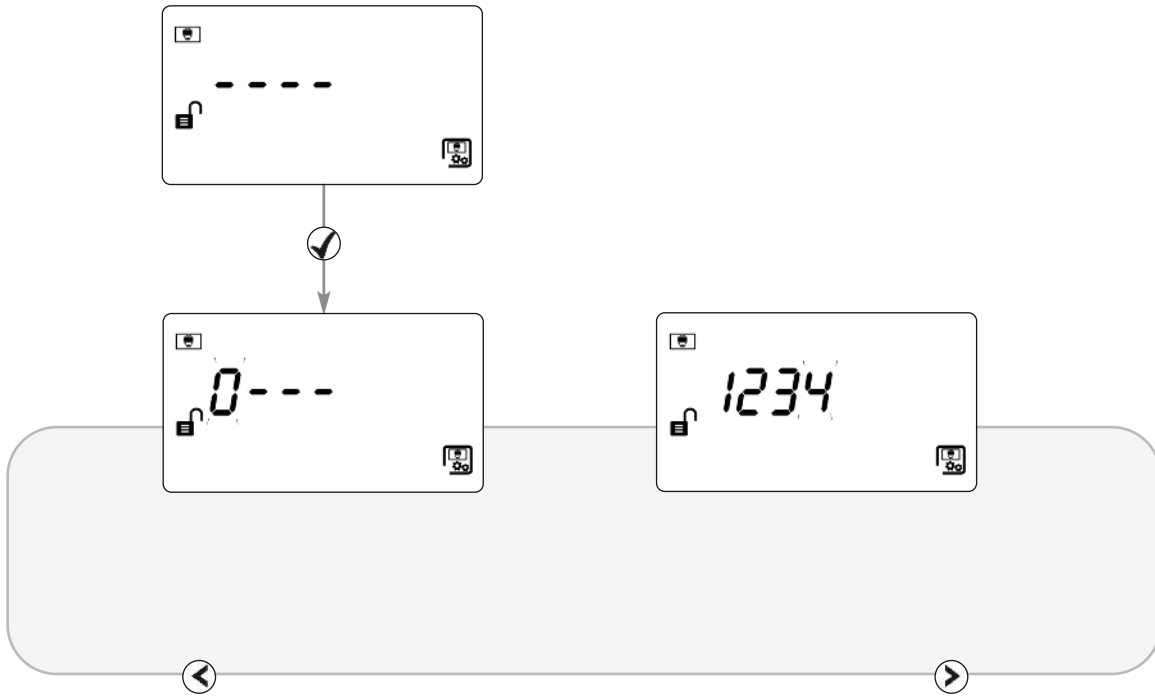

Default Pass Code: **1 2 3 4**

- ⬆ ⬇ Change digit
- ⬅ ➡ Move between digits
- ✔ Save new Pass Code
- ✘ Abort change

4.3.3 Controller Status LED ON/OFF Screen

This setting controls whether the System Controller Status LED will flash.

- OR Toggle ON or OFF
- Confirm setting
- Abort change

