

INSTALLATION INSTRUCTIONS
POTTER HORN STROBE, HORN AND STROBE WITH PRE-WIRE/PRE-TEST CEILING MOUNT (CLEAR AND AMBER LENS)

Use this product according to this instruction manual. Please keep this instruction manual for future reference.

GENERAL:

The Potter Electric series PE-HNC horn, PE-STC multi-candela strobe, and PE-HSC horn/strobe appliances are designed for easy installation with a pre-wire capable mounting plate. All models are for 24V operation. The PE-HNC horn is also for 12V operation. PE-STC and PE-HSC are designed for ceiling mounting only. PE-HNC may be mounted on the wall or ceiling.

The Potter PE series meets NFPA 2016 20 millisecond light pulse duration code requirements. The maximum number of PE series devices per NAC is determined by dividing the maximum current rating of the FACP NAC by the total current rating of one PE series device, with a maximum of 105 PE series strobe devices per NAC. Refer to FACP installation instructions for more detail.

The Potter PE series Multi-Candela Strobes provides a synchronized strobe appliance when used in conjunction with an FACP or power supply that incorporates the Wheelock Sync protocol.

CAUTION: Do not change factory applied finishes. "DO NOT PAINT".

ATTENTION: Ne pas modifier les finitions appliquées en usine. "NE PAS PEINTURER"

IMPORTANT: PLEASE READ THESE INSTRUCTIONS CAREFULLY. FAILURE TO COMPLY WITH ANY OF THE FOLLOWING INSTRUCTIONS COULD RESULT IN IMPROPER APPLICATION, INSTALLATION AND/OR OPERATION OF THESE PRODUCTS IN AN EMERGENCY SITUATION, WHICH COULD RESULT IN PROPERTY DAMAGE AND SERIOUS INJURY OR DEATH TO YOU AND/OR OTHERS.

SPECIFICATIONS:

Models	PE-STC (Strobe), PE-HSC (Horn-Strobe), PE-HNC (Horn), PE-xxC-A (Amber)
Agency	Horn: UL464, ULC-S525-16 Strobe: UL1638, UL1971, CAN/ULC-S526-16
Input Voltage	DC or FWR, 24V Regulated. 16 to 33V (All models) DC or FWR, 12V Regulated. 8 to 17.5V (PE-HNC only)
Horn Settings	Non-Sync: Continuous, Code 3 (field selectable) Wheelock Sync: Code 3 Sync, or T3/T4 Sync (selectable w/Wheelock Sync) Coded Operation: Use Continuous Setting on PE-HNC Horn Only Model
Horn Sound Output	High (H), Low (L). (field selectable)
Strobe Candela	15, 30, 75, 110, 150, 177cd (field selectable)
NAC Characteristics	Max. line resistance: 35Ω
Environmental	Indoor Use Only. 0° C - 50° C (32° F - 122° F) 93% R.H.

*UL1638 is an on axis rating where the following applies: effective candela rating per UL1971.

Horn Setting	Reverberant dBA at 10Ft per UL464		Anechoic dBA at 10 Ft per ULC-S525	
	PE-HNC at 12V	PE-HNC/PE-HSC at 24V	PE-HNC at 12V	PE-HNC/PE-HSC at 24V
CONT, T3, T3/T4 (H)	80	80	85	91
CONT, T3, T3/T4 (L)	78	78	79	86

-3dB	+/- 80 Degrees Horizontal, +/- 80 Degrees Vertical
-6dB	+/- 90 Degrees Horizontal, +/- 90 Degrees Vertical

Candela Setting	Regulated 24DC (16-33VDC)			Regulated 24FWR (16-33VRMS)		
	15cd	30cd	75cd	110cd	150cd	177cd
DC	0.022	0.030	0.060	0.086	0.125	0.185
FWR	0.036	0.050	0.092	0.142	0.196	0.274

When calculating the total strobe current: Use Table 3 to determine the highest value of "RMS Current" for an individual appliance, then multiply these values by the total number of appliances; be sure to add the currents for any other appliances powered by the same source and include any required safety factors.

Make sure that the total RMS current required by all appliances that are connected to the system's PRIMARY and SECONDARY power sources, NAC circuits, Sync Modules or Potter Power Supplies does not exceed the power sources' rated capacity or the current ratings of any fuses on the circuits to which these appliances are wired.

Check the minimum and maximum output of the power supply and standby battery, and subtract the voltage drop from the circuit wiring resistance to determine the applied voltage to the appliance.

Input	Horn Setting	Strobe Candela Setting					
		15cd	30cd	75cd	110cd	150cd	177cd
DC	CONT, T3, T3/T4 (H)	0.037	0.046	0.077	0.109	0.146	0.208
FWR	CONT, T3, T3/T4 (L)	0.030	0.039	0.070	0.102	0.139	0.201
DC	CONT, T3, T3/T4 (H)	0.064	0.078	0.130	0.180	0.230	0.310
FWR	CONT, T3, T3/T4 (L)	0.057	0.071	0.123	0.173	0.223	0.303

Input	Horn Setting	Regulated 12V (8-17.5V)	Regulated 24V (16-33V)
		DC	CONT, T3, T3/T4 (H)
FWR	CONT, T3, T3/T4 (L)	0.020	0.021
DC	CONT, T3, T3/T4 (H)	0.045	0.048
FWR	CONT, T3, T3/T4 (L)	0.035	0.038

WIRING DIAGRAMS:

Figure 1: PE-STC, PE-HSC, or PE-HNC

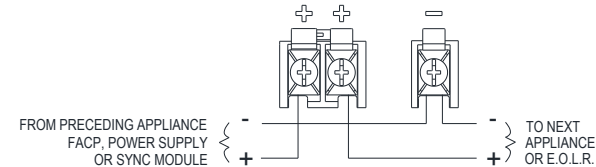

*Refer to Potter power supply or sync module instructions for additional information.

Figure 2:



1. This model has in-out wiring terminals that accept #12 to #18 American Wire Gauge (AWG) wires at each screw terminal. Strip leads 3/8 inches and connect to screw terminals.
2. Break all in-out wire runs on supervised circuits to assure integrity of circuit supervision as shown in Figure 2. The polarity shown in the wiring diagrams is for operation of the appliances. The polarity is reversed by the FACP during supervision.

NOTES:

1. Horn and Strobe settings will determine the current draw of the product.
2. The strobe will produce 1 flash per second over the "Regulated Voltage" range.
3. Strobe is not designed to be used on coded systems in which the applied voltage is cycled on and off.
4. The maximum number of PE series strobes on a single notification appliance circuit shall not exceed 105.
5. Amber strobes are not to be used as a Visual Public Mode alarm notification appliance.
6. These appliances are UL Listed as "Regulated". They are intended to be used with FACP's whose notification circuits are UL Listed as "Regulated." Refer to the FACP instructions for special application and strobe synchronization compatibility.
7. These appliances were tested to the regulated voltage limits of 16.0-33.0 Volts. Do not apply voltage outside of this range. Check the minimum and maximum output of the power supply and standby battery and subtract the voltage drop from the circuit wiring resistance to determine the applied voltage to the strobes. The max wire impedance between strobes shall not exceed 35 ohms.
8. Make sure that the total RMS current required by all appliances that are connected to the system's primary and secondary power sources, notification appliance circuits, sync modules, or Potter power supplies does not exceed the power sources rated capacity or the current ratings of any fuses on the circuits to which these appliances are wired.
9. The Code 3 temporal pattern (1/2 second on, 1/2 second off, 1/2 second on, 1/2 second off, 1/2 second on, 1-1/2 off and repeat) is specified by ANSI and NFPA 72 for standard emergency evacuation signaling. Code 3 Horn shall be used only for fire evacuation signaling and not for any other purpose.
10. The Code 4 temporal pattern (100 ms on, followed by 100 ms off, for 4 cycles, followed by 5 seconds of silence and repeat), is specified by ANSI and NFPA 720 for carbon monoxide emergency signaling.
11. The effect of shipping and storage temperatures shall not adversely affect the performance of the appliance when it is stored in the original cartons and not subjected to misuse or abuse.

SETTINGS: To set candela or horn, slide the selector switch to the desired setting. See Figure 3.

Figure 3: Settings (Set from rear)
Factory Setting is 15cd and T3(H).

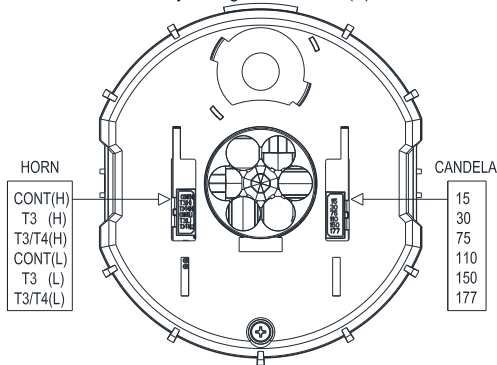

Strobe device has only one mounting orientation. LED light element should be oriented toward the floor

NFPA 72/ANSI 117.1 provide means for determining equivalent illumination using fewer, higher intensity strobes within the same area.

Application Notes: T3/T4 Operation with Wheelock Sync

T3/T4 Sync Selectable operation requires Wheelock Sync (using Silence/Resound Commands). All appliances must be set to T3/T4. Code 4 (T4) operation occurs with Wheelock Sync Resound Mode (No Silence). Code 3 (T3) operation occurs with Wheelock Sync Silence Mode (Audible Silence function is available only when using Continuous or T3 setting). A Wheelock DSM-12/24-R sync module may be used to facilitate T3/T4 operation.

Figure 5: Grille Removal **

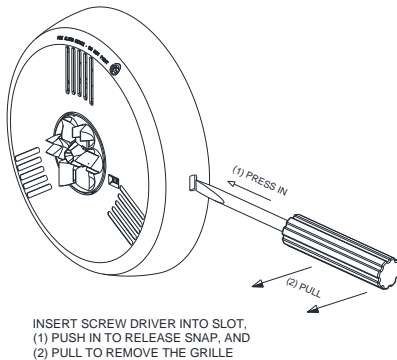

INSERT SCREW DRIVER INTO SLOT.
(1) PUSH IN TO RELEASE SNAP, AND
(2) PULL TO REMOVE THE GRILLE

**** Grille removal:** 1) Insert Screwdriver into slot, and push to release snap. 2) Remove the grille.

Check the installation instructions of the manufacturers of other equipment used in the system for any guidelines or restrictions on wiring and/or locating Notification Appliance Circuits (NAC) and notification appliances. Some system communication circuits and/or audio circuits, for example, may require special precautions to assure immunity from electrical noise (e.g. audio crosstalk).

This equipment has been tested and found to comply with the limits for a Class A digital device, pursuant to part 15 of the FCC Rules. These limits are designed to provide reasonable protection against harmful interference when the equipment is operated in a commercial environment. This equipment generates, uses, and can radiate radio frequency energy and, if not installed and used in accordance with the instruction manual, may cause harmful interference to radio communications. Operation of this equipment in a residential area is likely to cause harmful interference in which case the user will be required to correct the interference at his own expense.

This Class A digital apparatus meets all requirements of the Canadian Interference-Causing Equipment Regulations. Cet appareil numérique de la classe A respecte toutes les exigences du Règlement sur le matériel brouilleur du Canada.

Figure 4: Strobe Light Distribution

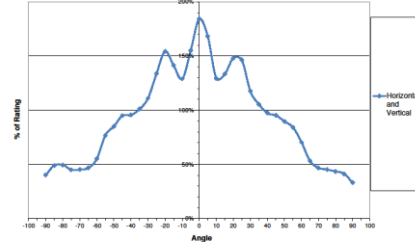

MOUNTING OPTIONS:

The following figures (A thru C) show the maximum number of field wires (conductors) that can enter the backbox used with each mounting option. If these limits are exceeded, there may be insufficient space in the backbox to accommodate the field wires and stresses from the wires could damage the product.

Check that the installed product will have sufficient clearance and wiring room prior to installing backboxes and conduit, especially if sheathed multiconductor cable or 3/4" conduit fittings are used.

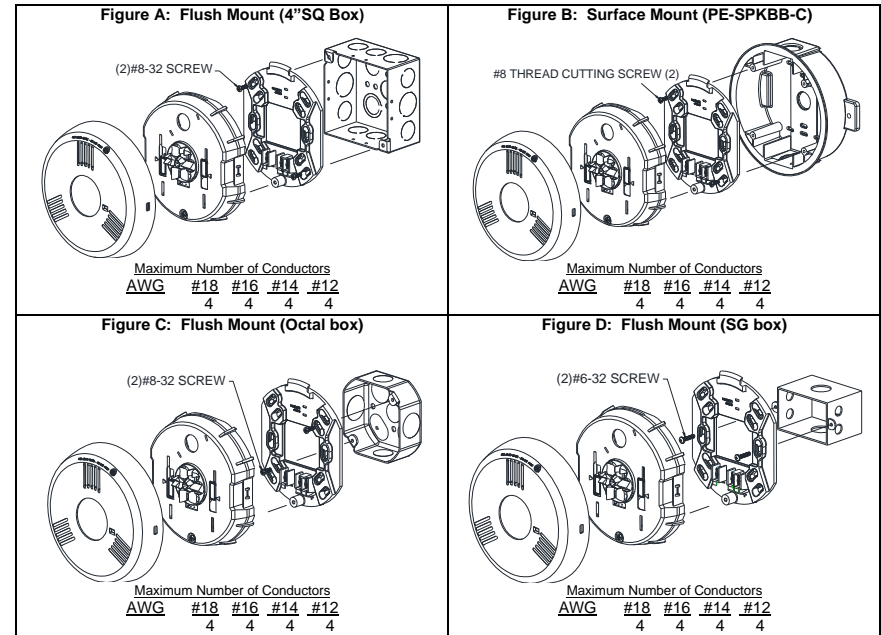

All installations shall be in accordance with:

- 1) In the United States, the National Electrical Code, NFPA 70, and the National Fire Alarm and Signaling Code, NFPA 72.
- 2) In Canada, CSA C22.1, Canadian Electrical Code, Part I, Safety Standard for Electrical Installations, Section 32; and the Canadian Standard for the Installation of Fire Alarm Systems - CAN/ULC-S524.

MOUNTING PROCEDURES:

1. Select a mounting option and install the backbox. Conduit entrances to the backbox should be selected to provide sufficient wiring clearance for the installed product. Do not pass additional wires (used for other than the signaling appliance) through the backbox. Such additional wires could result in insufficient wiring space for the signaling appliance.
2. Install the Mounting Plate on the backbox. Use 8-32 screws for 4" SQ or Octal; 6-32 screws for SG; or hi-lo screws for surface mount.
3. **Pre-Wire:** Connect field wires to terminals on mounting plate (reference Figure 1 and 2). Use care and proper techniques to position the field wires in the backbox so that they use minimum space and produce minimum stress on the product. This is especially important for stiff, heavy gauge wires and wires with thick insulation or sheathing. When terminating field wires, do not use more lead length than required. Excess lead length could result in insufficient wiring space for the signaling appliance.
4. **Pre-Test:** Mounting Plate contains a SHUNT between adjacent "+" terminals to facilitate testing before device is attached. Note: Shunt will open permanently when device is installed on mounting plate.
5. Verify appliance settings are correct for your application. Settings are shown in Fig. 3. Factory settings are 15cd and T3(H).
6. Place the appliance over the mounting plate. Engage TOP hook on mounting plate, then secure with screw at the bottom. Use care to prevent damage when driving the screw.
7. Align cover to the appliance with strobe opening over LED lens. Then, snap the cover in place.
8. To remove the appliance, insert a small flat-bladed screwdriver into the bottom opening 1/2" as shown in Figure 5. Then remove grille.

Important: Do not fully back out terminal screws. Do not over tighten screws or terminals. Excessive torque may affect operation. When using power tools, ensure the torque is set to the lowest setting available.

NOTE: Final acceptance is subject to Authorities Having Jurisdiction.

Any material extrapolated from this document or from Potter manuals or other documents describing the product for use in promotional or advertising claims, or for any other use, including description of the product's application, operation, installation and testing is used at the sole risk of the user and Potter will not have any liability for such use. IN NO CASE WILL SELLER'S LIABILITY EXCEED THE PURCHASE PRICE PAID FOR A PRODUCT.