

PIR-TECT 2

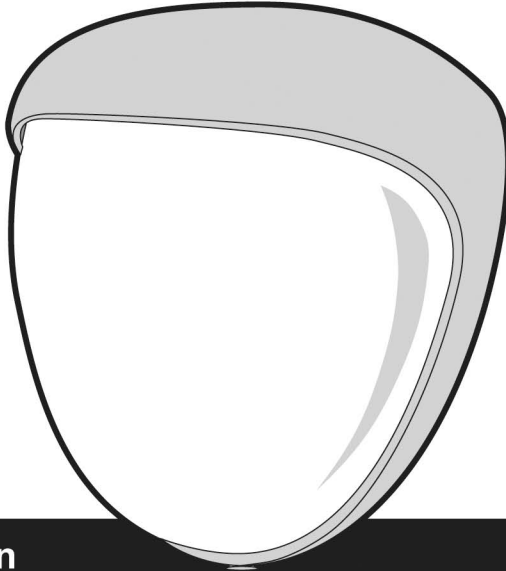

Movement Detector

Installation & Set Up Guide



Introduction

- A CCTV event trigger utilizing two independent passive infrared detectors combined in a T05 package and a microwave sensor. Both PIR sensors and the microwave have to trigger before the detector signals an alarm. This high precision, very reliable presence detector has been designed for use within CCTV installations.

Programmable parameters include a pulse count feature and a choice of detection ranges from 10 to 30 metres (33 to 98ft).

- Additionally, independent front and rear tamper circuits are combined to provide volt free tamper alarm contact.
- The integral dual axis tilt sensor allows 180° of pan and 90° tilt. This increases the speed of the outdoor installation and provides incredibly accurate aiming of the detection pattern. The electronics module is acrylic coated for additional component stability. It is encased in a vandal-resistant high impact zinc alloy housing with a UV stabilized translucent front cover ensuring the sensor is impervious to and unaffected by weather conditions. Additionally, the combination of precision electronics, digital white light filter and double shielding eliminates false alarms from the sun and other visible light sources.

The **PIR-TECT 2** design gives a neat and professional appearance with no visible indication of the orientation of the detector head, and completely hides the wiring.



Installation & Set Up Guide

PIR-TECT QUICK INSTALLATION

Apply supply voltage to the unit, the blue led flashes 3 times

The detector takes approximately 2-3 minutes to settle

The walk test LED is factory set to OFF. Pressing the program button once will enable the walk test led for 5 minutes.

THE FRONT COVER MUST BE FITTED WHEN WALK TESTING

FACTORY SETTINGS ARE:-

- 1 RANGE 98 FT.
- 2 PULSE COUNT 1
- 3 LED OFF

When enabled the **PIR-TECT 2** has three LED indicators.
Green - Microwave detection

Installation & Set Up Guide



Stage 1 – Mounting the unit

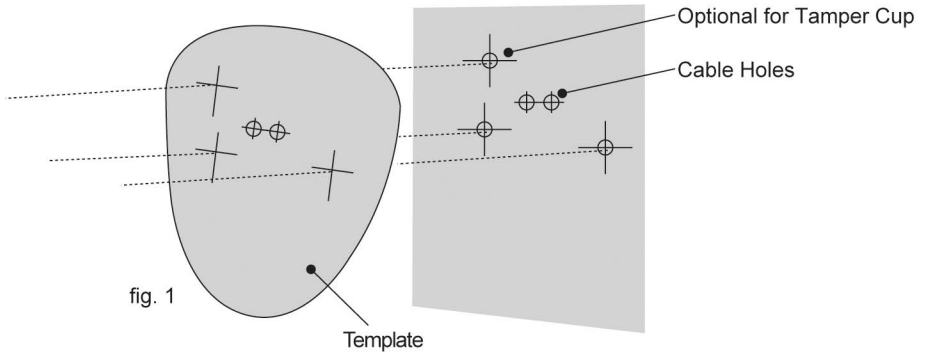

- During installation the electronics must be protected against water. Trapped moisture can affect or damage the unit.

1) Using the template provided drill the wall to accept the two fixing screws, the cable entry and the tamper cup (if used).

See fig. 1 and 2.

Note: We recommend using the tamper cup on uneven wall surfaces.

2) Remove the cover assembly by loosening the locking screw using the allen key provided. The cover hinges from the top and lifts out of the location slot.

See fig. 3.

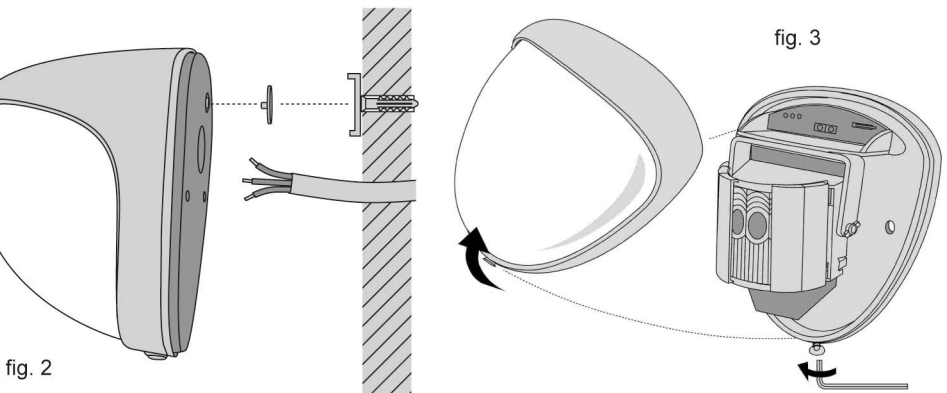

Installation & Set Up Guide



Stage 1 – Mounting the unit (Cont.)

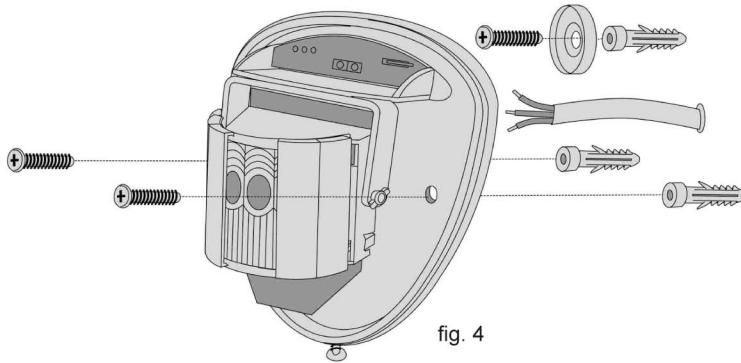

3) Feed standard unshielded twisted four pair alarm cable into the cable entry; bare the wires and connect to the removable terminal block as shown in fig. 7. Screw the unit to the wall ensuring that the tamper pin is correctly located and that the tamper microswitch is closed. **See fig. 4 and 5.** To aid installation, two spare tamper feet are provided. One is 0.04 inches longer and the other is 0.08 inches longer than the tamper foot originally fitted. The tamper foot is a push fit and can be removed by carefully pulling it from the pin. **See fig. 2.**

4) Always ensure when replacing the electronics module that the LED is facing forward to ensure correct alignment of the beam pattern. (Refer to section titled "Multibeam Alignment & Masking")

5) When the detector has been aligned to suit the installation, replace the front cover and lock as shown. **See fig. 6.**

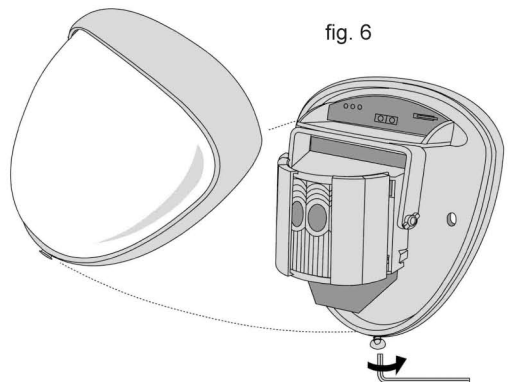
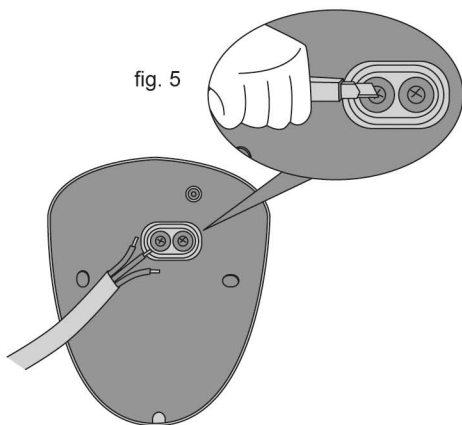

Installation & Set Up Guide



Stage 2 – Connecting the Unit

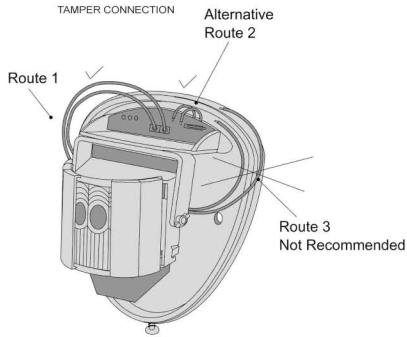

fig. 7

Stage 3 – Multibeam Alignment & Masking

- The multifunction lens fitted to the **PIR-TECT 2** detector produces 7 long range beams and 7 medium to short range curtain beams. Movement across the beams produces the best response and range for the PIRs, while movement towards the detector produces the best response for the microwave sensor. The unit detects the changes in heat and movement in the beam pattern. Items such as trees, shrubs, ponds, boiler flues and animals should be considered when positioning the detector.

- The detector module is fitted with two sliding shutters to reduce the detection angle. An additional set of curtains is provided should the beam pattern need to be narrowed even further, e.g. if the minimum detection angle of 10 degrees is required.

The curtains are fitted to the pan and tilt module as indicated in fig. 8 below. Each section or the detector's lens gives a coverage pattern of approximately 10 degrees.

See fig. 8.

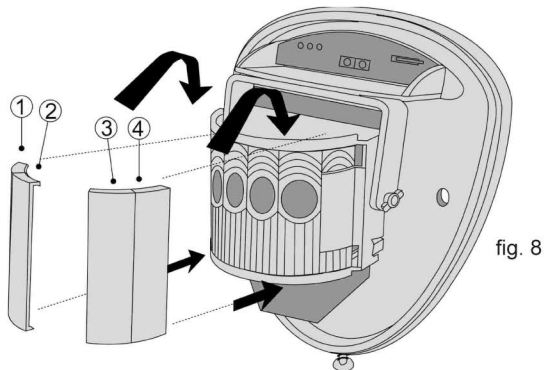

fig. 8

Installation & Set Up Guide



Stage 3 – Multibeam Alignment & Masking (Cont.)

- When mounting higher than boundary fences rotate the module and mask off any beams (vertically or horizontally), that fall outside the area being covered.

Use portions of the self-adhesive silver mask supplied to the rear, smooth side, of the lens as shown in the diagrams on the next page. Always replace the lens the correct way up to ensure exact beam pattern coverage (the top of the Fresnel lens is marked - TOP).

See fig. 9.

MULTIBEAM - OPTIMUM
 HEIGHT: 10 FEET
 RANGE: MAXIMUM
 MODULE TILT: 0 DEGREE

MULTIBEAM
 HEIGHT: 20 FEET
 RANGE: MAXIMUM
 MODULE TILT: 9 DEGREE

PET IMMUNITY
 HEIGHT: 5 FEET
 RANGE: MAXIMUM
 MODULE TILT: -2 DEGREE

CURTAIN COVERAGE
 HEIGHT: 20 FEET
 RANGE: MAXIMUM
 MODULE TILT: 45 DEGREE

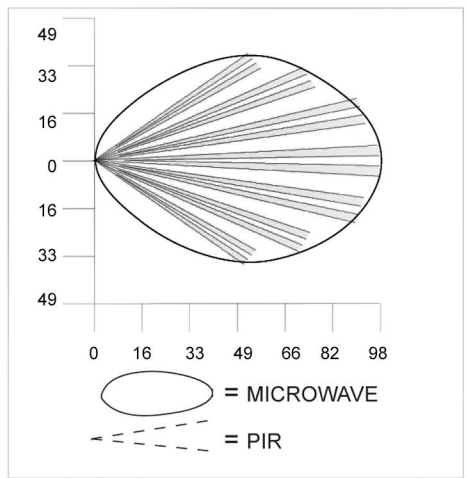

6

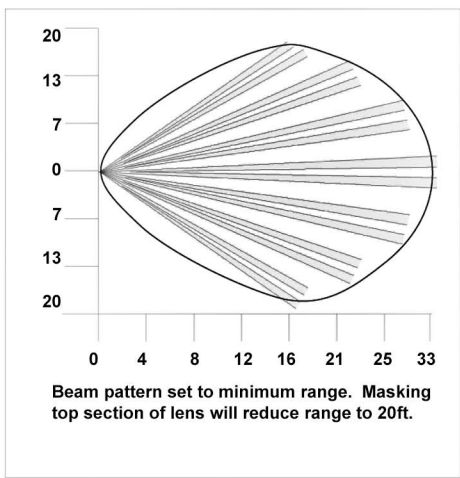

6

Installation & Set Up Guide



Stage3 – Multibeam Alignment & Masking (Cont.)

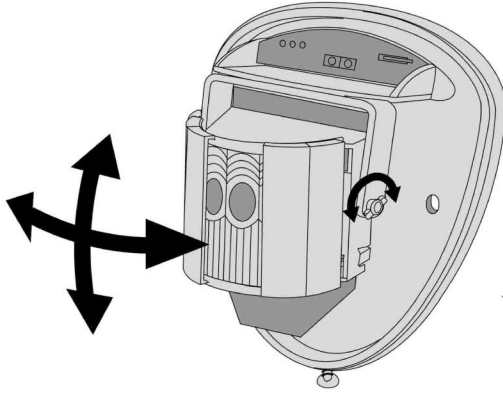

fig. 9

Stage 4 – Programming

- The user can individually program a number of configurable settings as illustrated in the programming chart. Factory settings are shown as shaded boxes. Changes to the existing settings can easily be made. To reset the factory settings simply remove power from the detector, press and hold the program button (fig. 10) while temporarily applying power to the detector either before installation, with a 9 Volt battery, or by applying 12 Volts to the unit on site.

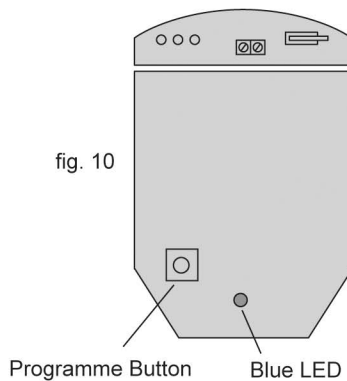

fig. 10

Installation & Set Up Guide



Stage 4 – Programming (Cont.)

PROGRAMMING CHART

		SETTING			
		1	2	3	
OPTIONS	1	RANGE FEET	33	66	98
	2	PULSE COUNT	1	2	
	3	LED	OFF	ON	

To change any of the **PIR-TECT 2** settings: -

- 1) Press the program button as shown in fig. 10 for the number of the Option to be changed i.e. once for range, twice for pulse count, three times for LED.
- 2) Wait four seconds until the blue LED indicator goes off.
- 3) The indicator will then flash out the existing setting.
- 4) To change the setting for that option, press the button the number of times required for the new setting.
- 5) The indicator blinks twice and the changes are stored.

Installation & Set Up Guide



Stage 4 – Programming (Cont.)

Any alterations made to the **PIR-TECT 2** settings are stored in the detector's non volatile memory.

EXAMPLE

To change the LED Setting from OFF to ON.

- 1) Press the program button three times and release the button.
- 2) Wait until the indicator goes off.
- 3) The indicator will now flash once.
- 4) Press the program button twice and release the button.
- 5) The indicator flashes twice showing that the option has been stored and the detector returns to normal operation.

Stage 5 – Walk Test

- The range of the detector increases without the front protective cover. Therefore the front cover must be fitted to establish the correct beam pattern alignment and when testing the outputs. Use the program table on page 8 to adjust the range as necessary and pan and tilt the lens module over the field of view to obtain the correct coverage area.

- When the 'program' button is pressed momentarily the blue indicator lights and pulse count '1' is automatically selected. The unit can then be aligned. The blue indicator will light on the **PIR-TECT 2** every time a detection takes place. This test mode will automatically cancel five minutes after last detection. Alternatively, remove the power and then re-apply.

Installation & Set Up Guide



Stage 6 – OPTION Definitions

PULSE COUNT

- This is the number of times the unit has to detect on both of its sensors before signalling an output. Pulse count of 1 is recommended for long-range applications. Pulse Count of 2 is recommended for short-range applications.

LED MONITOR

LED Off - LED disabled

LED On - LED signals a detection

N / OPEN & N / CLOSED

- These are magnetically immune volt free relay contacts used to trigger alarm inputs on connected equipment

The contacts are rated at a maximum of 24V AC/DC @ 50 mA.

ACCESSORIES

Amseco is able to supply the following accessories to aid installations:

PIR-305 Conduit cable entry adaptor ring

PIR-306 Pole mount clamp

PIR-307 Walk tester

Installation & Set Up Guide



INSTALLATION NOTES

PIR-TECT 2 Technical Specification



Detection Area	Programmable between 33 & 98 ft.	
Coverage	10-70 degrees detection angle, 98ft x 79ft coverage max.	
Adjustment	180 degree pan + 90 degree tilt.	
Fresnel Lens	28 zones for each Pyro pair, which can be masked with the curtain sliders.	
Customized Optics	Double silicon shielded quad element eliminates 50,000 lux of white light	
Microwave Module	Operating Frequency 10.525 GHz	
Outputs	Silent solid state magnetically immune.	
No.1	N /OPEN	Volt free relay signal contact 24VAC/DC @ 50mA Alarm time 5 seconds.
No.2	N / CLOSED	Volt free relay signal contact 24VAC/DC @ 50mA Alarm time 5 seconds
Power input	9 to 15 VDC.	
Current	15mA (12V nominal).	
Pulse Count	1 - 2.	
Temp. Compensation	Digital sensitivity adjustment.	
Control	Digital microprocessor - non volatile memory.	
Walk Test	Output test mode with LED indication.	
Operating Temp.	-4 to +131 Fahrenheit Conformal coated electronics for increased stability.	
Housing	High impact zinc alloy.	
Protection Rating	IP 55.	
Dimensions	5.71 x 4.72 x 4.52 inches	
Weight	25.46 Ounces NET, 21 Ounces GROSS.	
Mounting Height	Variable up to 20 ft - optimum height 10 ft.	
Cable < 200m	Utilizing all three outputs (incl. tamper) – unshielded twisted four pair AWG 24.	
Cable < 500m	Utilizing all three outputs (incl. tamper) – unshielded twisted four pair AWG 20.	
CE Mark	CE	

01105

Potter Electric Signal Co., LLC
5757 Phantom Drive.
Suite 125
St. Louis, Missouri 63042

Tel: 866-240-1870
Fax: 800-768-8377
www.pottersignal.com

