

Features

- Potter’s IntelliGen™ Controller (Patent Pending)
 - Fully automates the air fill and nitrogen fill procedure
 - Advance leak rate detection
 - Integrated Bypass alarm
 - Web Enabled – system can be monitored anywhere there is internet connectivity
 - Automatically e-mails trouble alerts and maintenance reminders
- Integrated 1 HP oil-less air compressor included to meet NFPA 13 required 30 minutes fill for 500 gallon system at 40 PSI.
- Handles up to 1,850 gallons of total sprinkler system capacity (based on NFPA 13 allowable leak rate of 1.5 PSI per 24 hours for a new sprinkler system).
- Skid mounted unit – easy plug and play installation.
- 20 gallons air tank and 20 gallon nitrogen tank.
- Form C dry contacts for Building Management System (BMS) notification.
- FM Approved per Approval Standard 1035, Nitrogen Generators.



Description

Potter’s IntelliGen™ Series of Nitrogen Generators are specifically designed to generate on-site, 98%+ purity nitrogen for use in fire protection sprinkler systems. When used as a supervisory gas in fire sprinkler systems, nitrogen slows corrosion, improves the life of your system, and lowers maintenance costs.

The INS-500 utilizes nitrogen membrane technology for gas separation. Nitrogen membranes are highly effective and a cost conscious way of producing on-site nitrogen. Acting as a gas filter, the nitrogen membrane separates the oxygen and water vapor molecules in the air from the nitrogen molecules. The high purity nitrogen gas is then piped through the air maintenance device and into the fire protection system. As the system fills with nitrogen, the remaining oxygen molecules in the fire protection system are exhausted by using the Potter IntelliPurge® Nitrogen Purge Valve. The Potter IntelliPurge® Nitrogen Purge Valve monitors the fire protection system to ensure high purity nitrogen is consistent throughout the sprinkler system.

The INS-500 is a fully assembled package ready to be connected to a new or existing fire sprinkler system. This turn-key system includes an integrated air compressor, nitrogen membrane, all air filtration equipment, tanks and the Potter IntelliGen™ Controller.

The Potter IntelliGen™ Controller ensures the contractor the easiest setup and operation of any nitrogen generator system in the industry. Each unit is designed to be turned on and walk away. The built-in monitoring capabilities will make corrections and alert you to any necessary changes.

Technical Specifications

Size	54" H x 42" W x 32" D
Weight	400 lbs
Power Supply Available in:	115VAC (10.4A) 230VAC (5.2A) single phase
Fire Sprinkler System Connection	½" Female NPT
Mounting Holes	(4) Ø 9/16"
Rated Working Pressure	105 PSI
Temperature Range	50°F (10°C) to 110°F (43°C)

Installation

The Potter INS-500 should be installed in a dry, clean, and well ventilated room with ambient temperatures above 50°F at all times. Allow access to the front for service and place the unit in a location that is conveniently located near fire sprinkler system connections, a drain, and a dedicated electrical connection. The Potter IntelliGen™ Nitrogen Generator should always be installed in an adequately ventilated room. Rapid release of nitrogen gas into an enclosed space displaces the oxygen and can cause an asphyxiation hazard. For detailed installation and operation instructions please refer to the Potter IntelliGen™ Nitrogen Generator Manual #5403645.

Dimensions

Fig 1

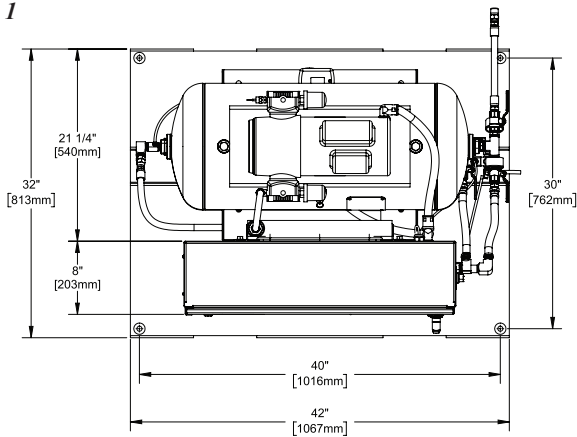

Fig 2

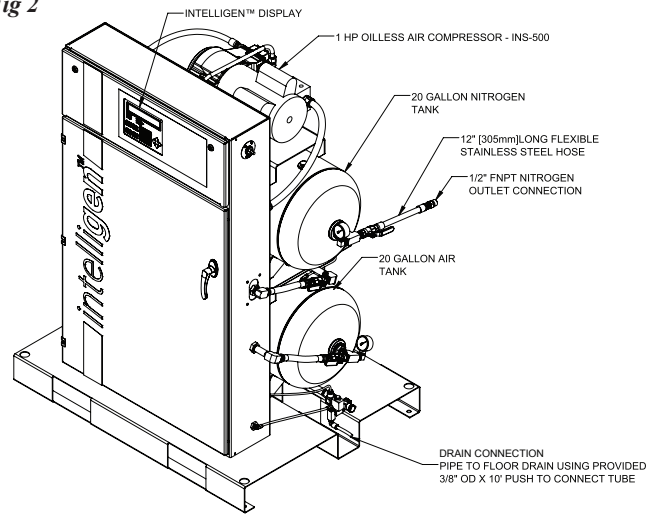

Fig 3

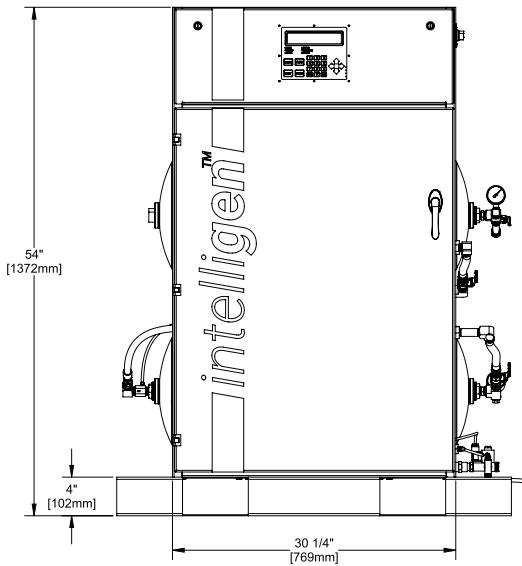
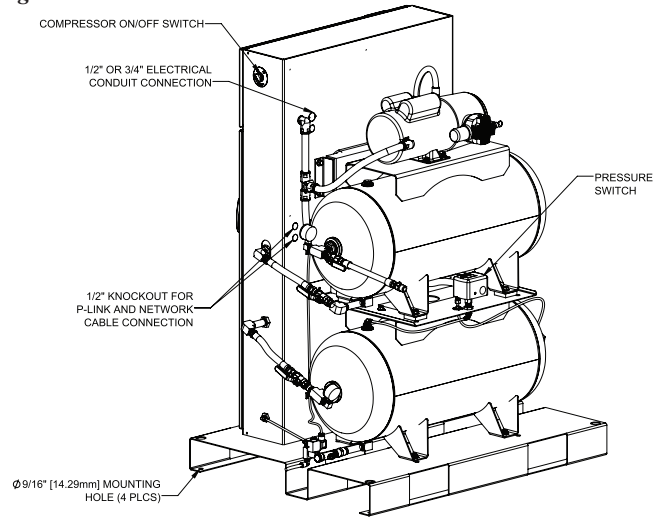

Fig 4



Ordering Information

Part Number	Model	Description
1119607	INS-500, 115VAC 1PH 60 HZ	IntelliGen™ Nitrogen System-500, 115VAC Single Phase
1119608	INS-500, 230VAC 1PH 60 HZ	IntelliGen™ Nitrogen System-500, 230VAC Single Phase
1119478	INS-PV	IntelliPurge® Nitrogen Purge Valve
1119784	NGP-SPV	Potter Purge Valve
1119660	NAMD	Potter Air Maintenance Device
1119504	PNA	Portable Nitrogen Analyzer