

Features

- Potter's IntelliGen™ Controller (Patent Pending)
 - Fully automates the air fill and nitrogen fill procedure
 - Advance leak rate detection
 - Integrated Bypass alarm
 - Web Enabled – system can be monitored anywhere there is internet connectivity
 - Automatically emails trouble alerts and maintenance reminders
- 7.5 HP lubricated tank mounted air compressor included to meet NFPA 13 required 30 minutes fill for 9030L (2,385 Gals.) system at 2,76 BAR (40 PSI) (276 kPa).
- Handles up to 90850 L (24,000 Gals.) of total sprinkler system capacity (based on NFPA 13 allowable leak rate of 0,103 BAR (1.5 PSI) (10,3 kPa) per 24 hours for a new sprinkler system).
- Three individual skids – 303 L (80 Gals.) tank mounted air compressor, nitrogen cabinet and Qty (2) 270 L (71 Gal) nitrogen tanks.



Description

Potter's IntelliGen™ Series of Nitrogen Generators are specifically designed to generate on-site, 98%+ purity nitrogen for use in fire protection sprinkler systems. When used as a supervisory gas in fire sprinkler systems, nitrogen slows corrosion, improves the life of your system, and lowers maintenance costs.

The INS-2500 (EU) utilizes nitrogen membrane technology for gas separation. Nitrogen membranes are highly effective and a cost conscious way of producing on-site nitrogen. Acting as a gas filter, the nitrogen membrane separates the oxygen and water vapor molecules in the air from the nitrogen molecules. The high purity nitrogen gas is then piped through the air maintenance device and into the fire protection system. As the system fills with nitrogen, the remaining oxygen molecules in the fire protection system are exhausted by using the Potter IntelliPurge® Nitrogen Purge Valve.

Note: The Potter IntelliPurge® Nitrogen Purge Valve is not CE Marked, CE Pending.

The Potter IntelliPurge® Nitrogen Purge Valve monitors the fire protection system to ensure high purity nitrogen is consistent throughout the sprinkler system.

The INS-2500 (EU) is to be connected to a new or existing fire sprinkler system. This system includes an air compressor, nitrogen membrane, all air filtration equipment, tanks and the Potter IntelliGen™ Controller.

The Potter IntelliGen™ Controller ensures the contractor the easiest setup and operation of any nitrogen generator system in the industry. Each unit is designed to be turned on and walk away. The built-in monitoring capabilities will make corrections and alert you to any necessary changes.

Technical Specifications

Compressor Package Size	1880mm (74") H x 940mm (37") W x 610mm (24") D
Nitrogen Cabinet Size	1778mm (70") H x 766mm (31") W x 314mm (13") D
Nitrogen Tank Size	1808mm (51 3/8") H x 508mm (20") Ø
Compressor Package Weight	300 kg (600 lbs)
Nitrogen Cabinet Weight	118 kg (260 lbs)
Nitrogen Tank Weight	159 kg (350 lbs) (2 required)
Air Compressor Power Supply* Available in:	380-415 VAC (11.1A) three phase 50 Hz
Max Operating Pressure	10,00 BAR (145 PSI) (1,000 kPa)
Temperature Range	10°C (50°F) to 43°C (110°F)

***Note:** Requires two (2) 220 V 50 Hz connections for nitrogen cabinet and air tank blow-down solenoid.

Installation

The Potter INS-2500 (EU) should be installed in a dry, clean, and well ventilated room with ambient temperatures above 50°C at all times. Allow access to the front for service and place the unit in a location that is conveniently located near fire sprinkler system connections, a drain, and a dedicated electrical connection. The Potter IntelliGen™ Nitrogen Generator should always be installed in an adequately ventilated room. Rapid release of nitrogen gas into an enclosed space displaces the oxygen and can cause an asphyxiation hazard. For detailed installation and operation instructions please refer to the Potter IntelliGen™ Nitrogen Generator Manual #5403681.

Cabinet Dimensions

Fig 1

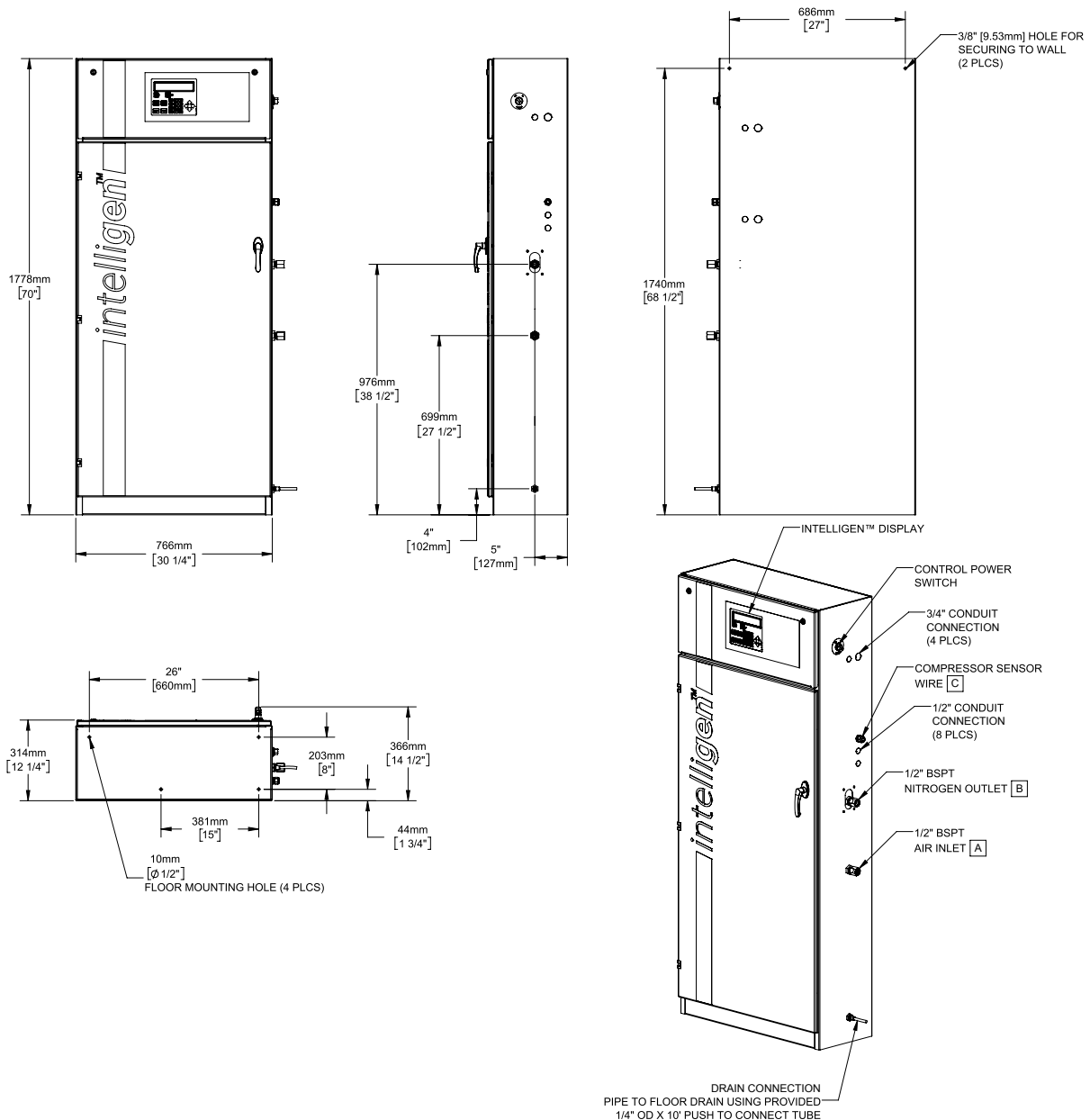

Tank Dimensions

Fig 2

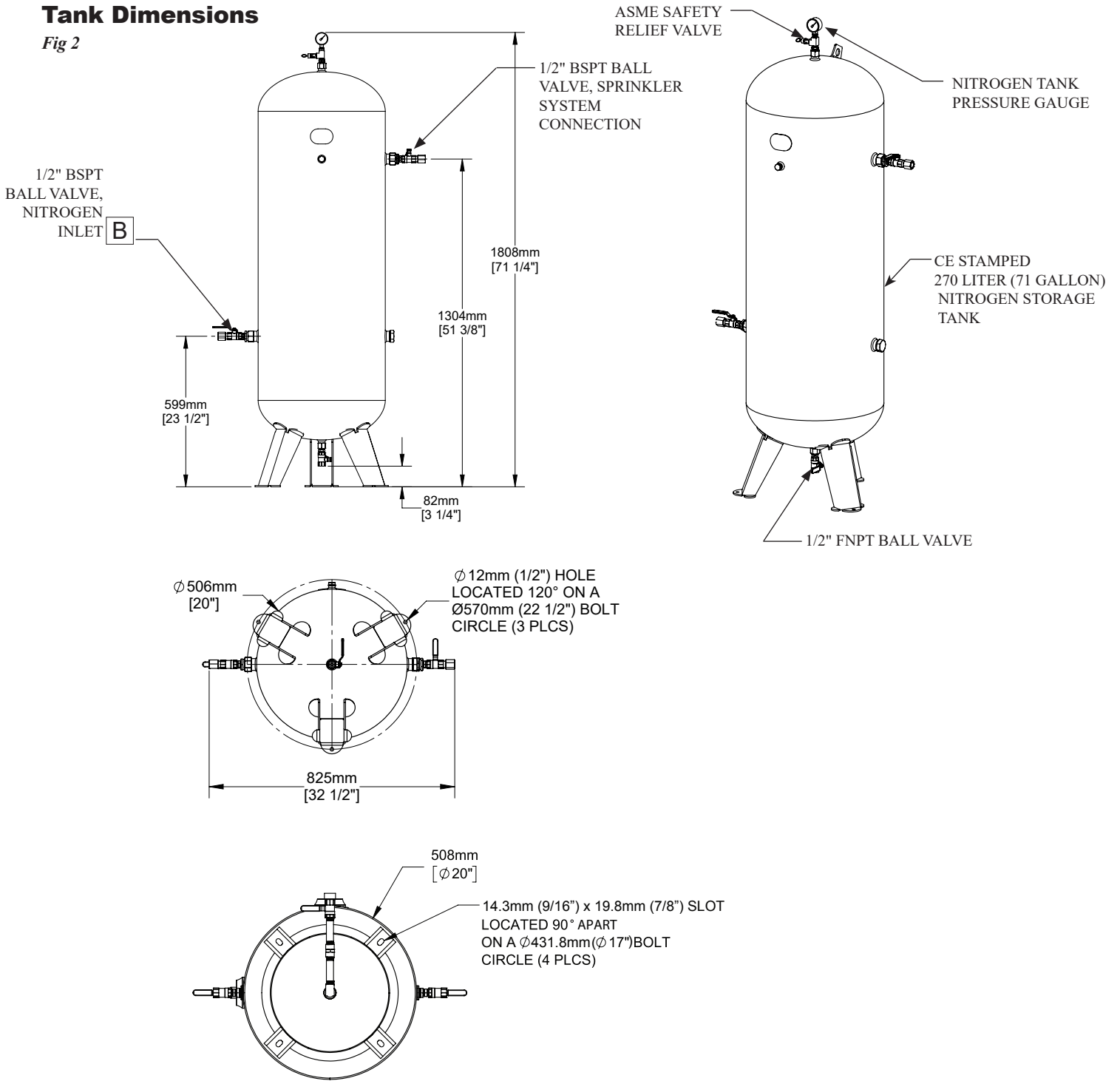

Alternate Tank

Note: INS-2500 (EU) requires two 227 L (60 Gals.) tanks.

Compressor Dimensions

Fig 3

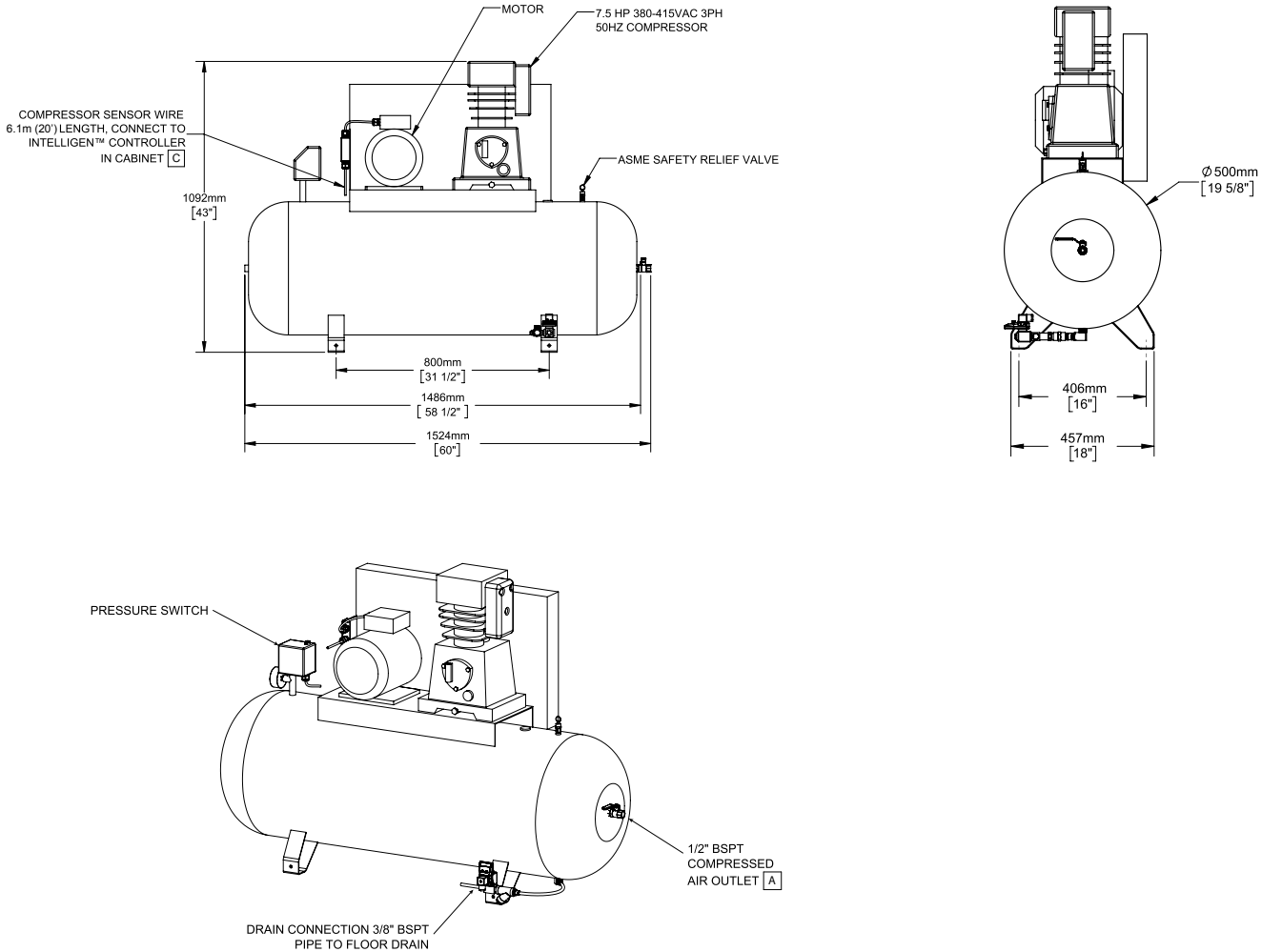

Ordering Information

Part Number	Model	Description
1119654	INS-2500 (EU), 380-415VAC 3PH 50 HZ	IntelliGen™ Nitrogen System-2500 (EU) , 380-415VAC Three Phase
1119478	INS-PV	IntelliPurge® Nitrogen Purge Valve*
1119784	NGP-SPV	Potter Purge Valve
1119621	NGP-AMD-1	Potter Air Maintenance Device
1119504	PNA	Portable Nitrogen Analyzer

* **Note:** The Potter IntelliPurge® Nitrogen Purge Valve is not CE Marked, CE Pending.