

Features

- Allows for Peer-to-Peer networking via Ethernet (CAT5)
- Up to 200 panels can be networked together
- Any RA-6500 remote annunciator can be set as a global annunciator
- NCE-1000 and NCF-1000 are interoperable and both types can be used within a network
- Allows for a single panel to act as the host communicator
- Five year warranty included

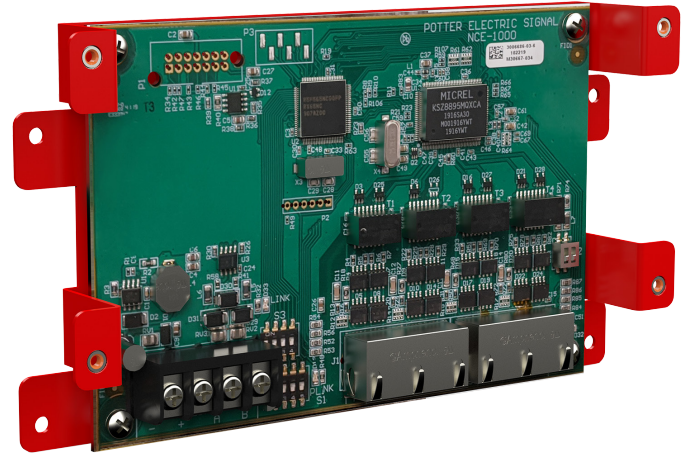

Description

The NCE-1000 is used to network the fire alarm panels using CAT5 Ethernet cable. It is fully supervised and is capable of Class B and Class A operation. The NCE-1000 may be mounted in either the control panel cabinet, the PSN-1000/E, the AE-2, AE-8 or AE-14. When wiring Class A or B, the connection between the FACP and the module shall be limited to 20 feet and enclosed in conduit or equivalently protected against mechanical injury.

Each card is mounted to the exclusive Stacker Bracket for secure and accessible mounting. A maximum of 31 NCE-1000s can be installed per panel, with a maximum of 200 panels per network.

Technical Specifications

Standby Current	50 mA
Alarm Current	50 mA
Operating Temperature Range	32° to 120°F (0° to 49° C)
Operating Humidity Range	10%-93% (non-condensing)
Operating Voltage Range	24 VDC
Max no. of NCE-1000	31
Dimensions (WxHxD)	4" x 6" x 1 5/8"
Max Wire Length for Ethernet Cable	300 ft
Wire Gauge P-Link	12 AWG - 18 AWG
Compatible Panels	IPA/AFC Series Addressable PFC-4064 Conventional

Installation

The NCE-1000 is connected to the fire control panels using a 4-wire RS-485 connection and Ethernet cable that connects to panel's P-Comm port.. The connection is power limited and supervised. The NCE-1000 can be mounted in either the control panel cabinet, intelligent power supply, the AE-2, AE-8 or AE-14. Each card is mounted to the exclusive Stacker Bracket for secure and accessible mounting. The connection between the FACP and the module shall be limited to 20 feet.

Fig 1

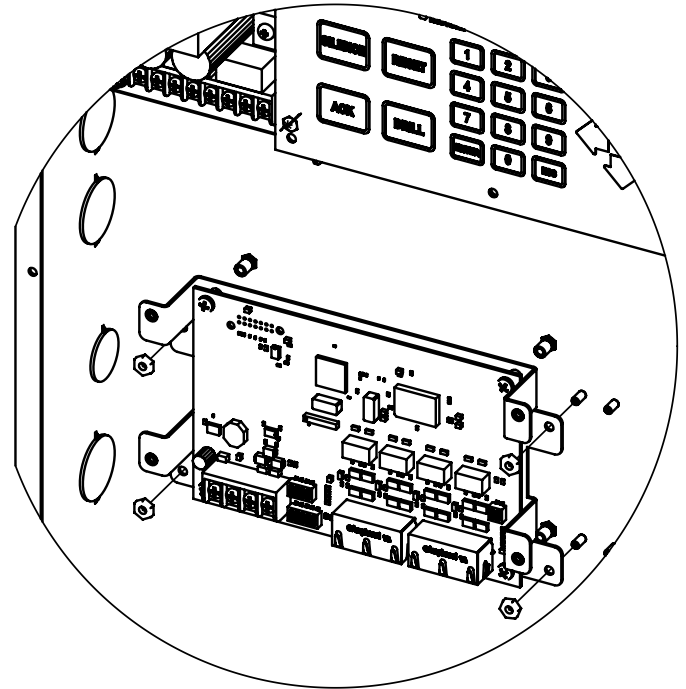

Class B Wiring

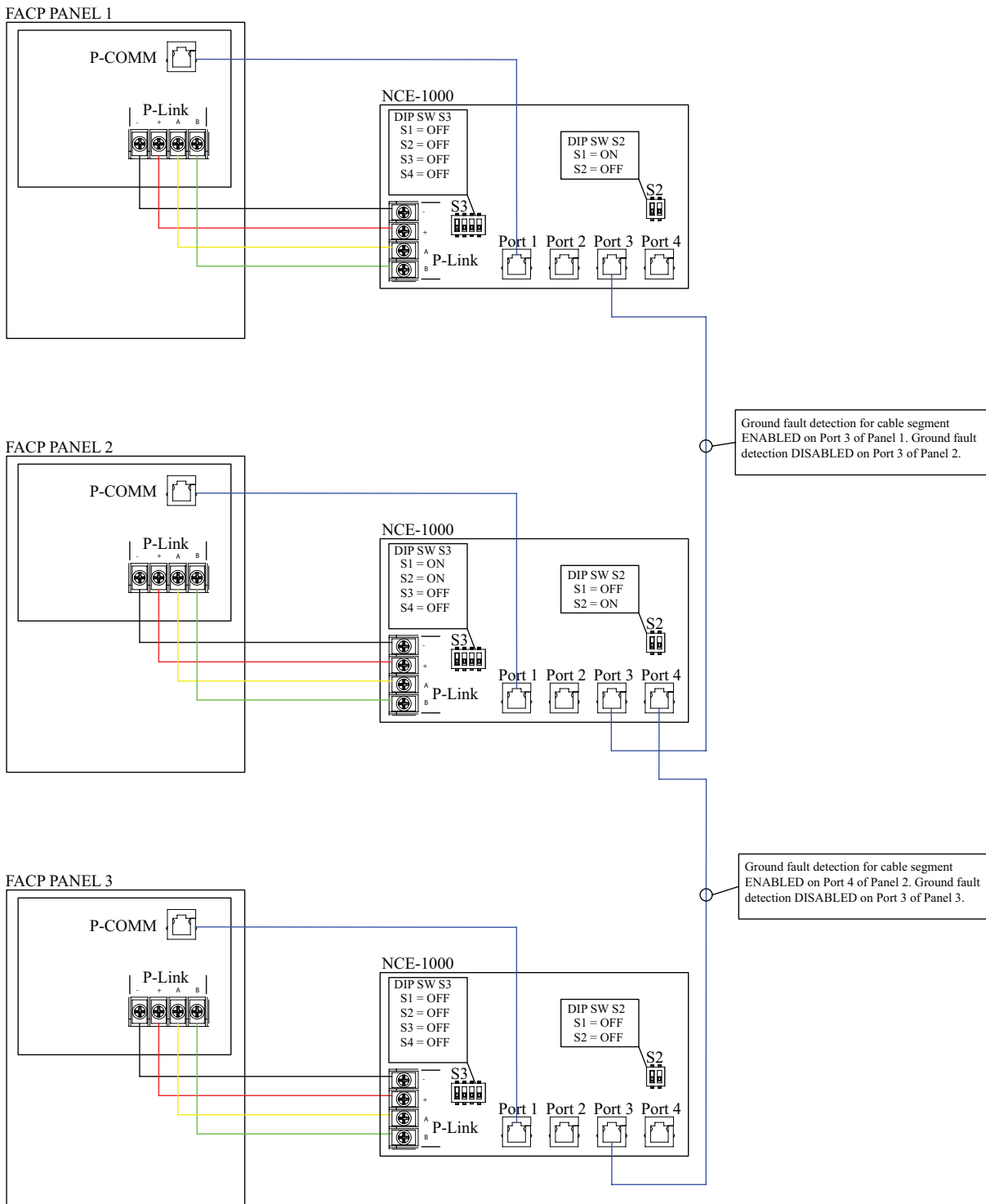

Class A Wiring with Return

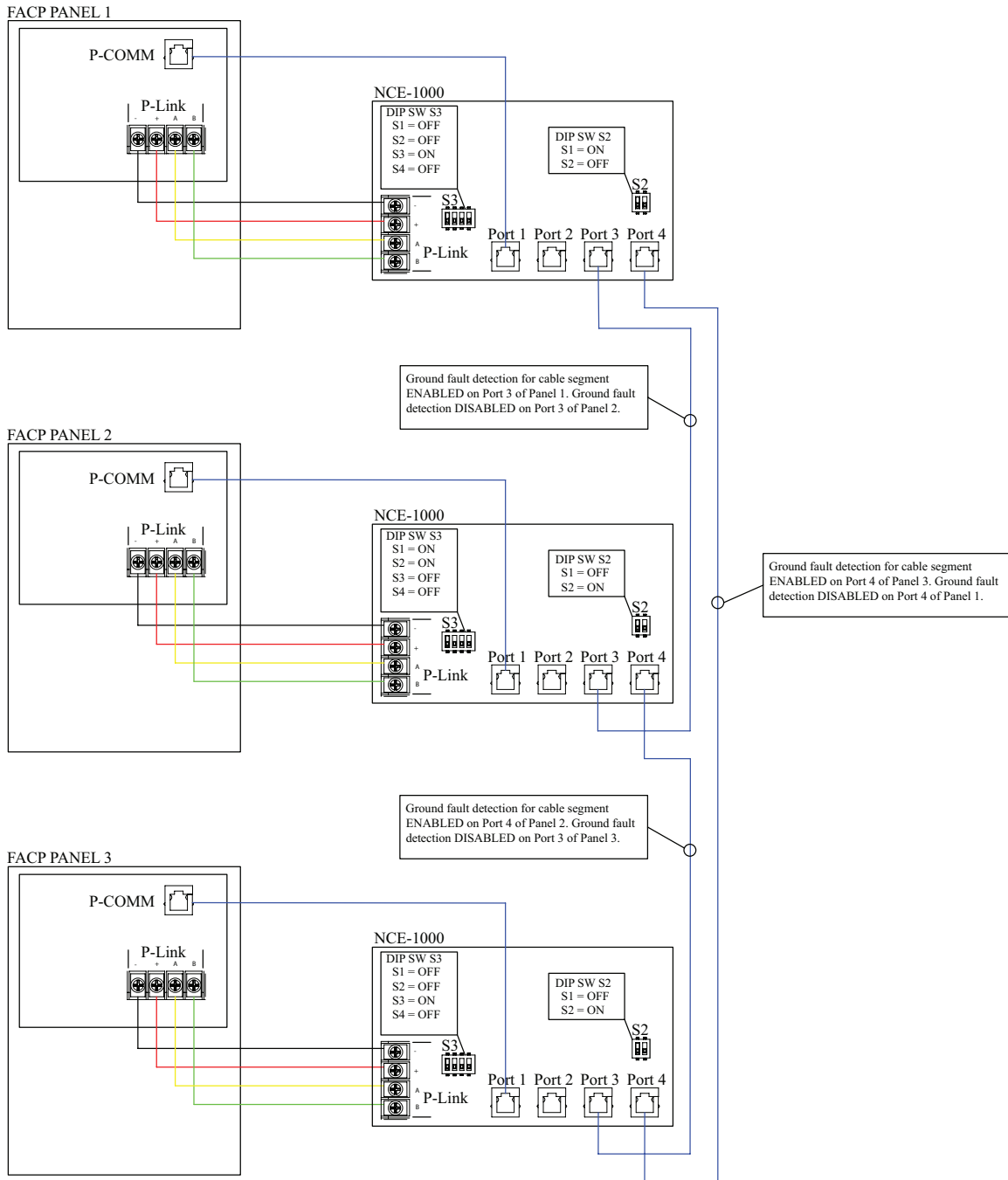

Ordering Information

Model	Description	Stock No.
NCE-1000	Network Card-Ethernet	3992788

Note: For additional wiring diagrams and schematics, please reference the Potter 8830161 Peer to Peer Networking Guide.