

# NGP-1000D-M1/M2/M3

## Installation, Operation, & Service Manual



Potter Electric Signal Company, LLC

St. Louis, MO

Customer Service: (866) 240-1870 • Technical Support: (866) 956-1211 • Fax: (314) 595-6999

[www.pottersignal.com/corrosion](http://www.pottersignal.com/corrosion)

Manual #5401549–Rev. A

9/15



**Table of Contents**

**Safety .....4**

**System Overview .....6**

**Before Going to the Job Site.....9**

**Uncrating and Inspection .....10**

**Installation of Nitrogen Generator .....11**

**Wiring of NGP-1000D-M1/M2/M3.....12**

**Installation of Nitrogen Purging System.....13**

**Standard Air Filling Method.....14**

**Nitrogen Purging Procedure .....17**

**Nitrogen Control Module .....20**

**Nitrogen Generator Alarms/Troubleshooting .....21**

**Nitrogen Generator Leak Check Method .....23**

**Air Side Leak Check Method.....24**

**Nitrogen Membrane Check.....25**

**Sprinkler System Leak Check .....26**

**NGP-1000D-M1/M2/M3 Maintenance.....27**

**Normal Operating Parameters of the NGP-1000D-M1/M2/M3 .....29**

**Nitrogen Analyzer Instructions.....30**

**Wiring Diagrams.....33**

**Technical Specifications and Drawings .....35**

**Warranty.....39**

# 1. Safety

## Safety Guidelines

This manual contains safety information that is important to know and understand. This information is provided for the safety of installers, operators, and users of the Potter Nitrogen Generator. To help recognize this information, observe the following symbols.



Danger indicates an imminently hazardous situation which, if not avoided, WILL result in death or serious injury.



Warning indicates a potentially hazardous situation which, if not avoided, COULD result in death or serious injury.



Caution indicates a potentially hazardous situation which, if not avoided, MAY result in minor or moderate injury.



Notice indicates important information, that if not followed may cause damage to equipment or property.

## Important Notice to Users

The Installation and Owner’s Manual supplied with each unit must be read thoroughly and completely understood before installation and operation of the Potter Nitrogen Generator. All appropriate safety standards for handling of gases as determined by local or national laws and regulations should be followed at all times.

## Unpacking

After unpacking unit, carefully inspect all parts and equipment for any damage that may have occurred during transit. Make sure to tighten fittings, bolts, etc. before putting unit into service.



## General Safety Information

Important: Read all of the safety information in this manual before operating this equipment. Use of the equipment in a manner not specified within this manual may impair the protection provided by the generator and could result in an unplanned release of pressure, which may cause serious injury or damage. Only competent personnel, who have been trained, qualified, and approved by Potter Electric Signal Company should perform commissioning, servicing, and repair procedures.

When handling, installing, or operating this equipment, personnel must employ safe engineering practices and observe all related local regulations, health, and safety procedures, and legal requirements for safety.

Ensure that the equipment is depressurized and electrically isolated, before carrying out any of the scheduled maintenance instructions specified in this manual.

The warnings in this manual cover the most known potential hazards, but by definition cannot be all-inclusive. If the user employs an operating procedure, item of equipment, or a method of working that is not specifically recommended by Potter Electric Signal Company, the user must ensure that the equipment will not be damaged or become hazardous to persons or property.

Nitrogen is not a poisonous gas. However, in a concentrated form, there is a risk of asphyxiation. The generator produces a flow of nitrogen and oxygen enriched air which quickly disperses in the atmosphere. However, do not directly inhale the output gas from the outlet pipe.

The generator is classified as non-hazardous for transportation purposes and as non-flammable for fire regulations. This equipment is for indoor use only. Do not operate outdoors.

## **WARNING**

Operation of the nitrogen membrane separator above the rated design pressure may be hazardous. Do not connect it to compressed air sources that can exceed its maximum rated pressure without installing appropriate pressure controls and safety relief devices in the compressed air supply line.

Specific procedures must be developed for maintenance of the equipment on which the membrane separator is located. Appropriate labels must be continuously displayed in all areas where personnel might be exposed to a nitrogen atmosphere under normal or upset condition.

## **NOTICE**

Do not attempt to disassemble the nitrogen membrane separator. Equipment damage may occur and cause the system to function incorrectly.

## 2. System Overview

The Potter Nitrogen Generator operates using membrane technology. The smaller oxygen and water vapor molecules can pass through (permeate) the membrane quickly. The larger nitrogen molecules are less likely to diffuse through the separator tubes; therefore, they continue downstream to the separator outlet. The permeated molecules are discharged to the atmosphere through a vent in the separator casing.

The Potter Nitrogen Generator is specifically designed to provide clean, dry, high purity nitrogen for use in fire protection sprinkler systems. The generator is a fully assembled package ready to be connected to a new or existing fire sprinkler system using a factory pre-engineered air compressor. These turn-key systems include all air filtration equipment required to keep the generator operating at peak efficiency.

Figure 1: NGP-1000D-M1/M2/M3 System Diagram

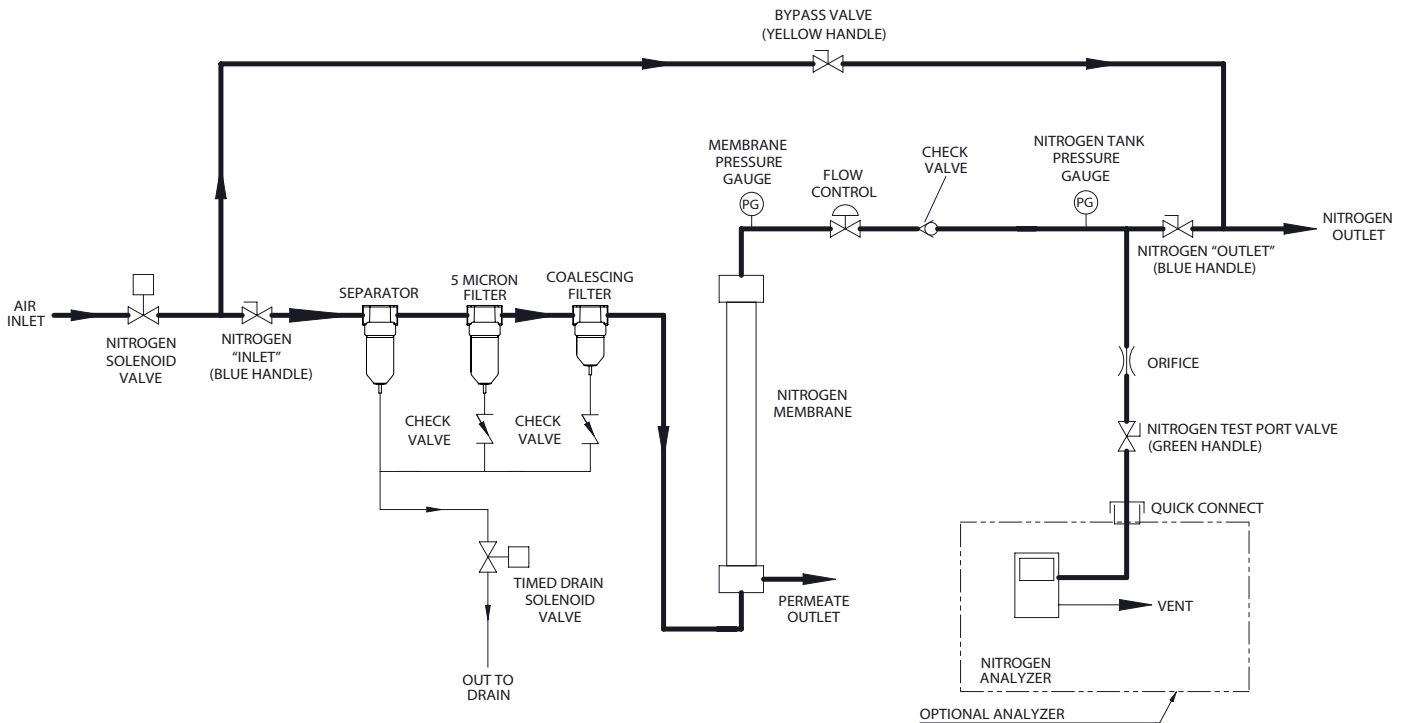
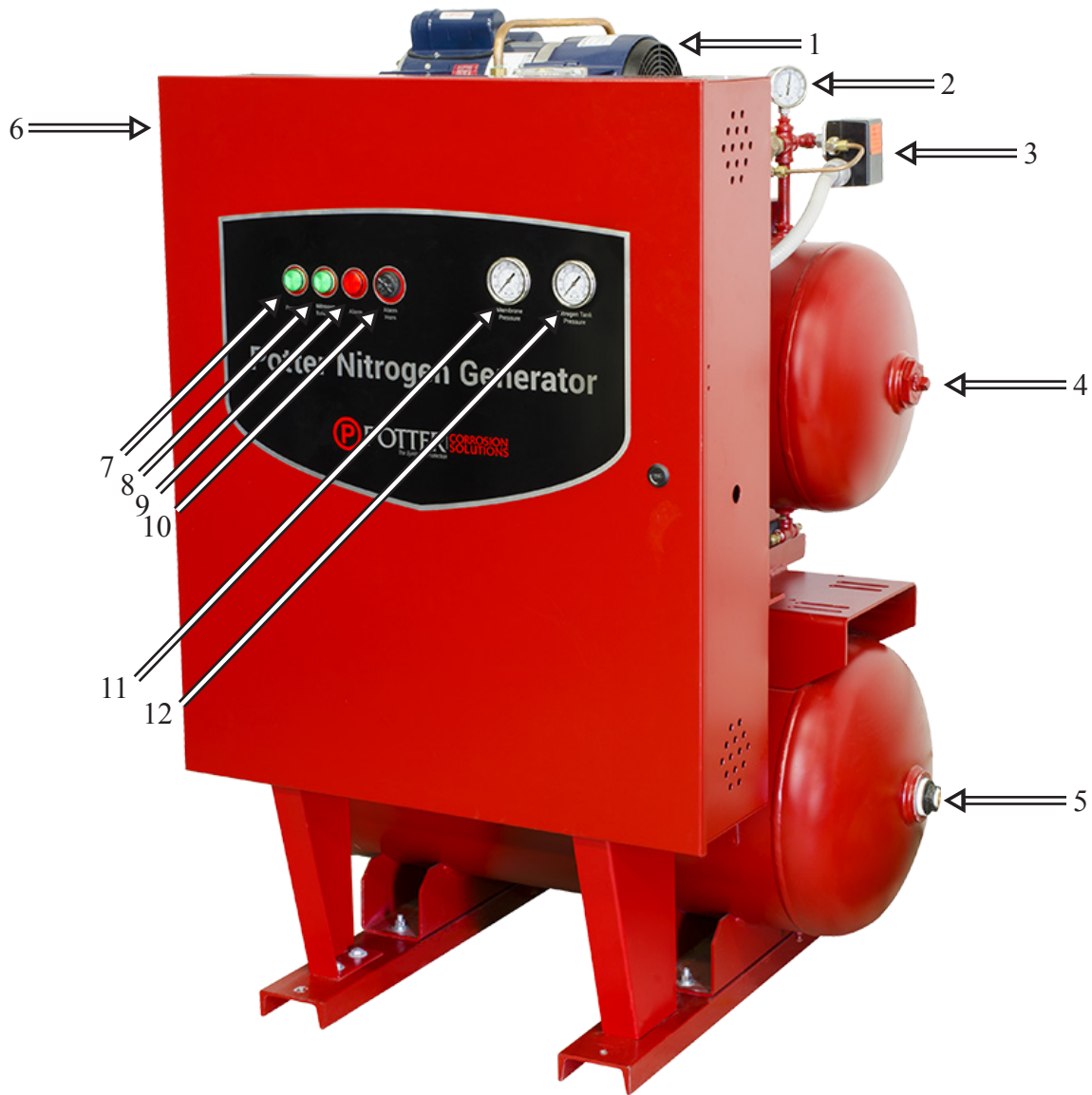
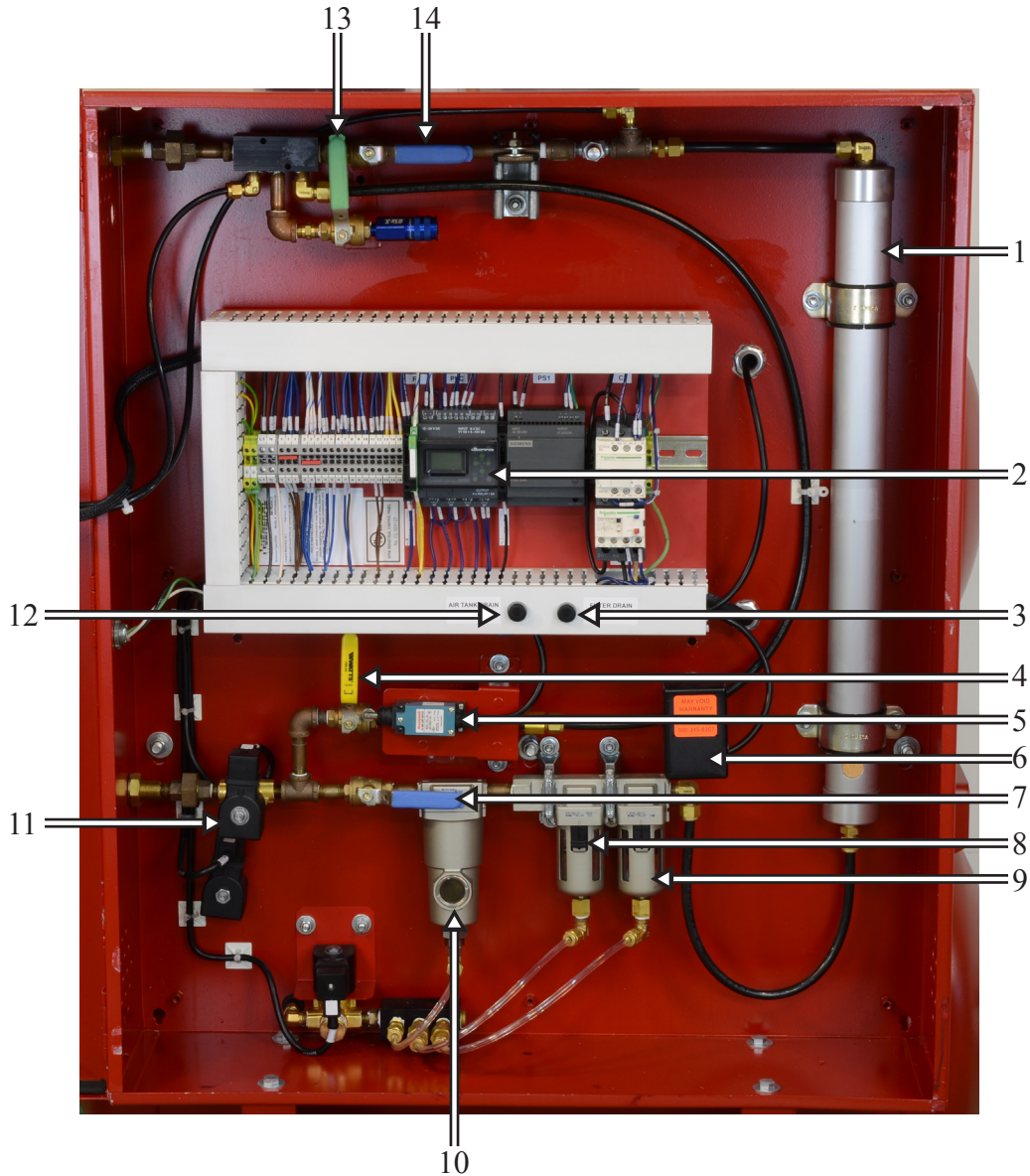

Figure 2: Typical NGP-1000D-M1/M2/M3 External View



- |                             |                                  |
|-----------------------------|----------------------------------|
| 1. Air Compressor           | 7. Power On Light                |
| 2. Air Tank Pressure Gauge  | 8. Nitrogen Solenoid Light       |
| 3. Air Tank Pressure Switch | 9. Alarm Light                   |
| 4. Air Storage Tank         | 10. Alarm Horn                   |
| 5. Nitrogen Storage Tank    | 11. Membrane Pressure Gauge      |
| 6. Nitrogen Cabinet         | 12. Nitrogen Tank Pressure Gauge |

Figure 3: Typical NGP-1000D-M1/M2/M3 Internal View



- |   |   |
|---|---|
| 1. Nitrogen Membrane                    | 8. 5 Micron Filter                          |
| 2. Nitrogen Control Panel               | 9. Coalescing Filter                        |
| 3. Filter Drain Solenoid Test           | 10. Separator                               |
| 4. Bypass Valve (Yellow Handle)         | 11. Nitrogen Solenoid Valve                 |
| 5. Bypass Alarm Switch                  | 12. Air Tank Drain Solenoid Test            |
| 6. Nitrogen Tank Pressure Switch        | 13. Nitrogen Test Port Valve (Green Handle) |
| 7. Nitrogen "Inlet" Valve (Blue Handle) | 14. Nitrogen "Outlet" Valve (Blue Handle)   |



### 3. Before Going To The Jobsite

1. Find a location for the nitrogen generator to be installed meeting these requirements:

Dimensions 62" x 44" x 33" (H x W x D)	
Dry, clean, and well-ventilated	
Ambient temperatures above 50° F at all times	
Access to front for service	
Conveniently located near fire sprinkler system connections	
Conveniently located near drain	

#### **WARNING**

The Potter Nitrogen Generator creates a 30% to 40% oxygen stream which may pose a flammability problem in an oxygen-sensitive environment. Pipe per installation requirements and ensure the area surrounding the nitrogen generator is adequately ventilated.

The Potter Nitrogen Generator should always be installed in an adequately ventilated room. Nitrogen is nontoxic and largely inert. Rapid release of nitrogen gas into an enclosed space displaces the oxygen and can cause an asphyxiation hazard. Inhalation of nitrogen in excessive concentrations can result in unconsciousness without any warning symptoms.

2. Run a dedicated electrical circuit with an electrical disconnect switch to sprinkler room.

Part #	Model	Phase	Amperage	Voltage
1119514	NGP-1000D-M1-2A	SINGLE	11.6	208V
1119515	NGP-1000D-M1-3A	SINGLE	11	230V
1119516	NGP-1000D-M1-2B	THREE	9.2	208V
1119517	NGP-1000D-M1-3B	THREE	9.2	230V
1119518	NGP-1000D-M1-4B	THREE	4.6	460V
1119519	NGP-1000D-M2-2A	SINGLE	11.6	208V
1119520	NGP-1000D-M2-3A	SINGLE	11	230V
1119521	NGP-1000D-M2-2B	THREE	9.2	208V
1119522	NGP-1000D-M2-3B	THREE	9.2	230V
1119523	NGP-1000D-M2-4B	THREE	4.6	460V
1119524	NGP-1000D-M3-2A	SINGLE	11.6	208V
1119526	NGP-1000D-M3-3A	SINGLE	11	230V
1119527	NGP-1000D-M3-2B	THREE	9.2	208V
1119528	NGP-1000D-M3-3B	THREE	9.2	230V
1119529	NGP-1000D-M3-4B	THREE	4.6	460V

## 4. Uncrating and Inspection

1. On arrival, do a full inspection by checking all packages and crates in the shipment for damage. If damage is found, sign for the damage or refuse the shipment. Contact the carrier immediately and file a shipping damage claim with the carrier.
2. Check to ensure all components are contained and no visible damage has occurred during shipping.

### ⚠ CAUTION

Important: Read all of the safety information in this manual before installing or operating this equipment.

#### NGP-1000D-M1/M2/M3 crate checklist:

Item	
Nitrogen cabinet	
Air storage tank (top tank)	
Nitrogen storage tank (bottom tank)	
Oil-less air compressor	
Nitrogen membrane (inside cabinet)	
Manual (inside cabinet)	
10 ft. 1/4" condensation drain tubes (inside cabinet)	

3. Each nitrogen generator requires a minimum of one Air Maintenance Device and one Nitrogen Purge Valve per system (Model NGP-SPV or INS-PV). Check to see these components have arrived.

#### NGP-1000D-M1/M2/M3 required accessories:

Item	
Air Maintenance Device (One per riser)	
NGP-SPV or INS-PV(One per riser)	
Nitrogen Analyzer (One per job)	



AMD-1



INS-PV

#### Required items supplied by sprinkler contractor:

Item	
4 anchor bolts (fit 1/2" holes on frame)	
NPT piping from generator to system (1/2" or greater)	
Dedicated electrical circuit with electrical disconnect	
1/4" drain tubing if more than 10 ft. are needed	
1/2" ball valve for isolation	

## 5. Installation of Nitrogen Generator

1. Anchor the unit to a level surface using the (4) ½” diameter holes on the frame. It is recommended practice to use vibration isolation kit to prevent excess vibration. See Figure 4.

Figure 4

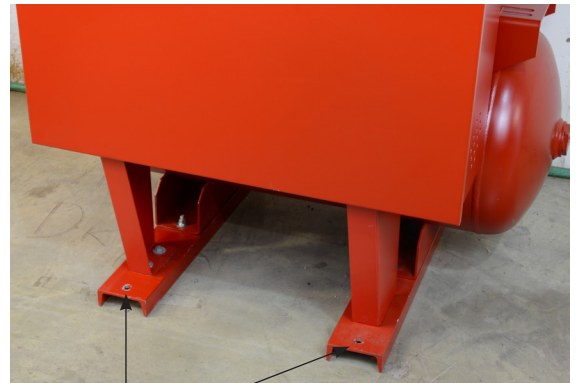

Mounting Holes

2. Install a ½” ball valve at the nitrogen storage tank outlet connection. The nitrogen storage tank comes with one ½” female NPT connection located on each side. Choose the one that is most convenient. Plug the opposite tank connection. See Figure 5.
3. Close the ½” ball valve.
4. Install ½” NPT piping from ½” ball valve on the nitrogen storage tank to the sprinkler system Air Maintenance Device using standard accepted installation practices. A flex hose can be used to prevent excess vibration.

Figure 5



Contractor Provided  
½” NPT Ball Valve

5. Install the included drain tube at the drain union tee on the back of the nitrogen cabinet. See Figure 6.
6. Install the second included drain tube at the separator located next to compressor aftercooler.  
**NOTE:** Tubing will need to be restrained as air pressure from the drain valve may cause the tubing to be displaced from the drain.

Figure 6

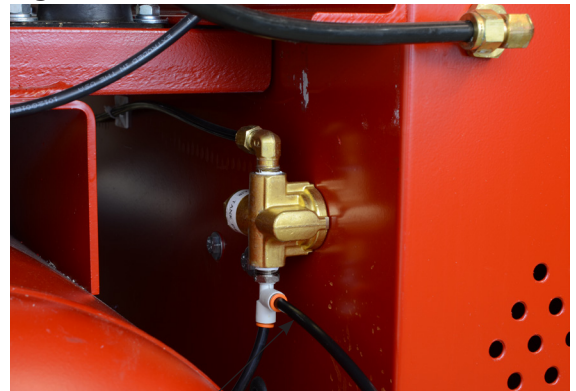

¼” Drain Tubing

7. Install ½” NPT pipe (or larger) from the Air Maintenance Device (AMD) to the sprinkler system using standard accepted installation practices. Additional system components may be required. See Figure 7.

Figure 7

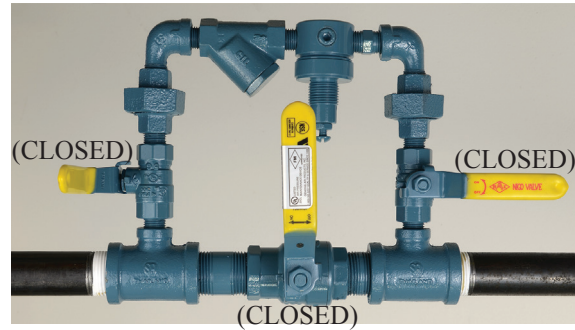

**NOTE:** AMD shown in closed position.

## 6. Wiring of NGP-1000D-M1/M2/M3

Wire the NGP-1000D-M1/M2/M3. All wiring should be performed by a licensed electrician and conform to NEC and all applicable local standards. For wiring instructions refer to the Wiring Diagram on page 34. Wiring location is in the nitrogen cabinet. See Figure 8.

Figure 8

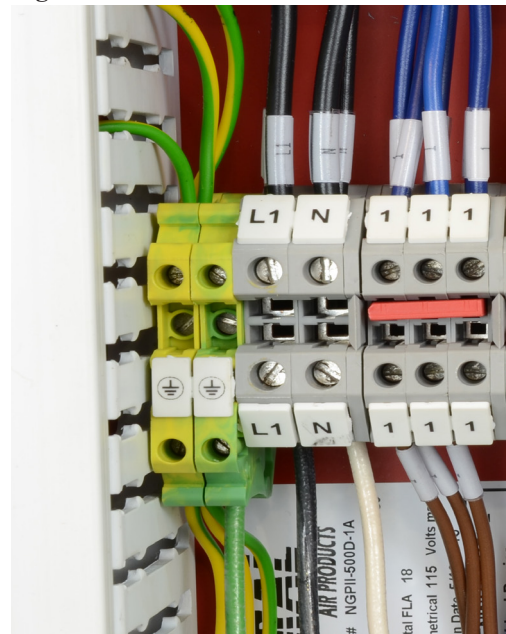

## 7. Installation of Nitrogen Purging System

Each riser requires a minimum of ONE Nitrogen Purge Valve to be installed prior to implementing the Nitrogen Purging Procedure.

For installation instructions, refer to the Model NGP-SPV Bulletin (#5401520) or Model INS-PV Manual (#5401532) supplied with each purge valve.



NGP-SPV  
(Potter Purge Valve #1117984)



INS-PV  
(Potter IntelliPurge Nitrogen Purge Valve #1119478)

### **CAUTION**

Purge Valves must be installed in a level horizontal position (shown above).

## 8. Standard Air Filling Method

1. Before beginning, make sure the water supply to the sprinkler system is turned off.
2. Make sure all piping connections have been made according to installation instructions.
3. Close all Air Maintenance Device valves. If multiple AMDs are used, ensure all valves are in closed position. See Figure 9.

Figure 9

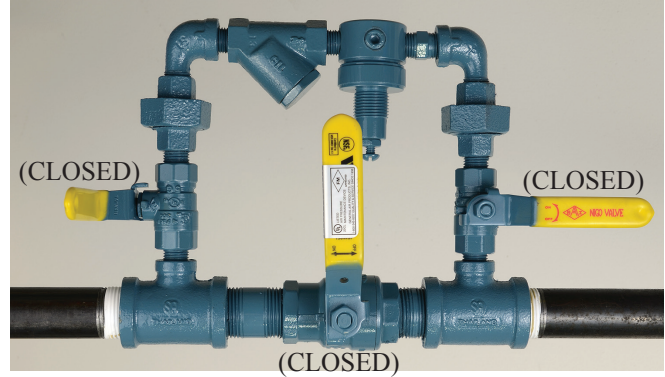

**NOTE:** AMD shown in closed position

Figure 10

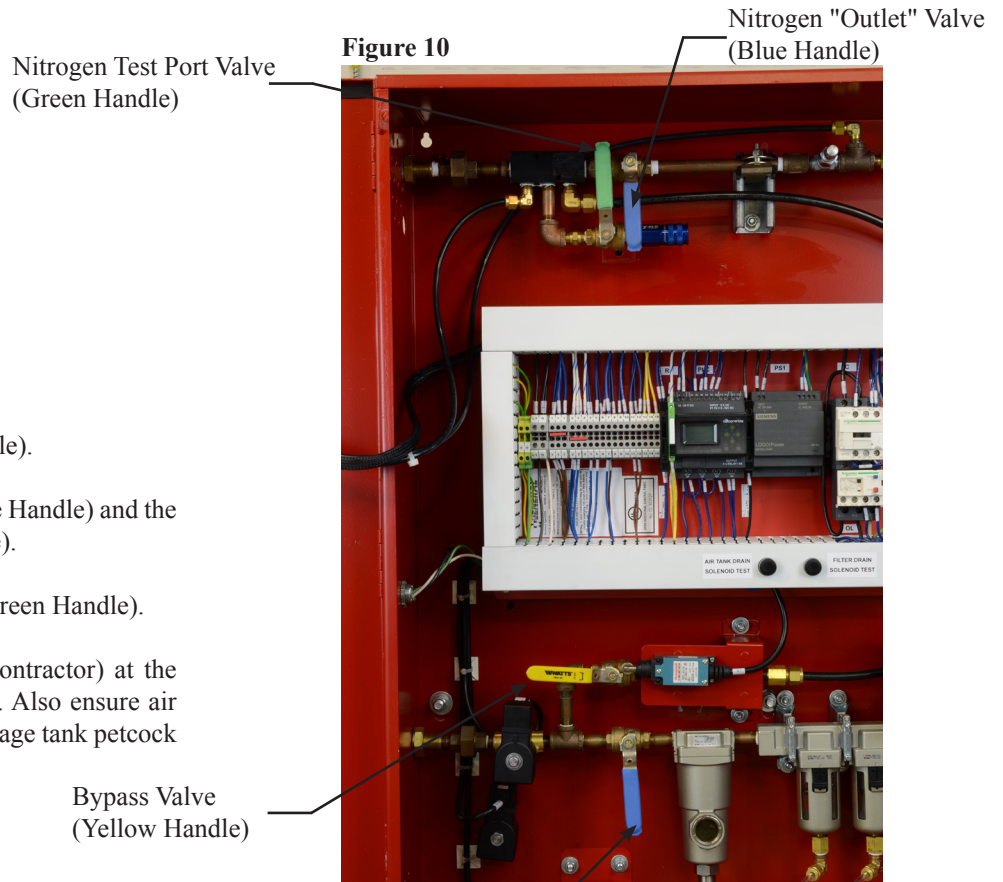

As shown in Figure 10:

4. Open the Nitrogen cabinet.
5. Open the Bypass Valve (Yellow Handle).
6. Close the Nitrogen "Inlet" Valve (Blue Handle) and the Nitrogen "Outlet" Valve (Blue Handle).
7. Close the Nitrogen Test Port Valve (Green Handle).
8. Ensure the ball valve installed (by contractor) at the nitrogen storage tank outlet is closed. Also ensure air storage tank petcock and nitrogen storage tank petcock are closed.

Nitrogen "Inlet" Valve  
(Blue Handle)

9. Power the nitrogen generator system ON. The Power On light and the Nitrogen Solenoid light should turn green. See Figure 11.

Figure 11

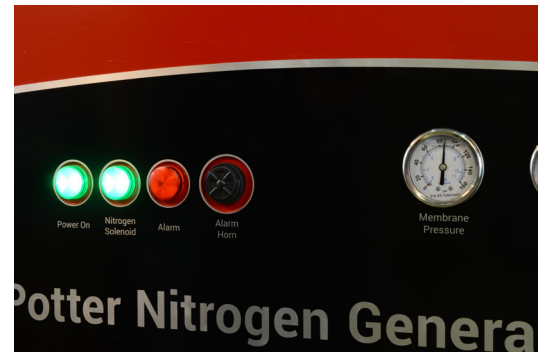

10. The nitrogen storage tank will fill to  $75 \pm 3$  PSI, then the nitrogen solenoid will close. The Nitrogen Solenoid light should now be off. See Figure 12.

Figure 12



11. The compressor will shut off at  $105 \pm 3$  PSI air storage tank pressure. This should not take longer than 7 minutes for the NGP-1000D-M1/M2/M3. See Figure 13.
12. Check all piping connections for leaks, as pre-plumbed piping may have loosened during shipping.

Figure 13



13. Using the installed petcock at the bottom of the air storage tank, relieve the pressure until the air compressor turns ON. The air compressor should turn on at  $85 \pm 3$  PSI. Close the petcock valve. See Figure 14.
14. The air compressor will run for a maximum of 60 seconds to refill the air storage tank for the NGP-1000D-M1/M2/M3. The air compressor will turn off at  $105 \pm 3$  PSI. If the unit takes longer than the prescribed time, or does not stop running when the unit reaches  $105 \pm 3$  PSI. Go to the *Troubleshooting* section, page 21.

Figure 14

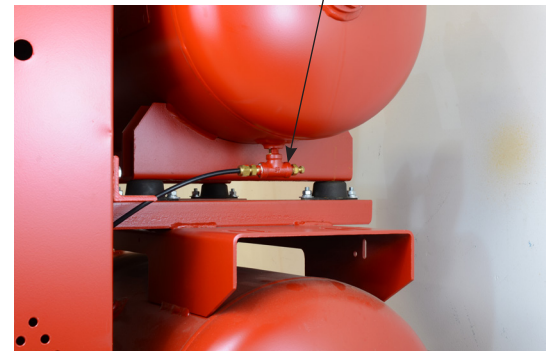
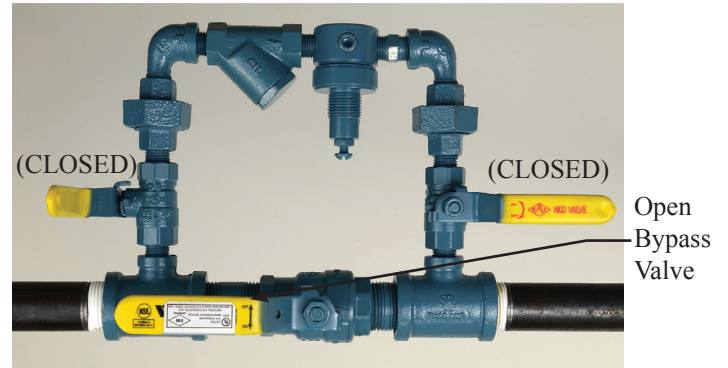

Figure 15



**NOTE:** AMD shown in bypass position

15. The nitrogen generator is now ready to fill the fire sprinkler system to the desired supervisory pressure.
16. Open the ball valve at the nitrogen storage tank outlet.
17. Open the Air Maintenance Device bypass valve to begin filling the sprinkler system. See Figure 15.

**CAUTION**

If there is more than one AMD on the system, then close the others. Fill one system at a time.

Figure 16

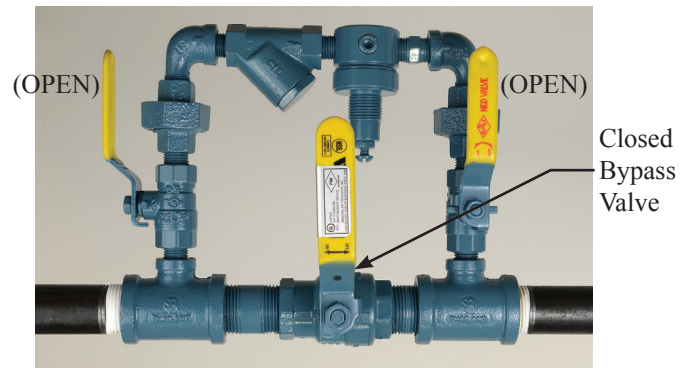

**NOTE:** AMD shown in maintenance position

18. Allow the sprinkler system to reach the desired pressure.  
**NOTE:** This should finish in 30 minutes per the desired NFPA guidelines.
19. As soon as sprinkler system supervisory pressure is reached, put the sprinkler system back into service by placing the Air Maintenance Device in the maintenance position (refer to the air maintenance device manual for proper operation). See Figure 16.

**CAUTION**

If there is more than one AMD on the system, fill EACH system individually and repeat steps 15 through 19



## 9. Nitrogen Purging Procedure

1. Once the system is at the desired supervisory pressure, it is time to start injecting nitrogen and purging the oxygen.
2. Close the Bypass Valve (Yellow Handle).
3. Open the Nitrogen "Inlet" Valve (Blue Handle).
4. Open the Nitrogen "Outlet" Valve (Blue Handle).

Figure 17

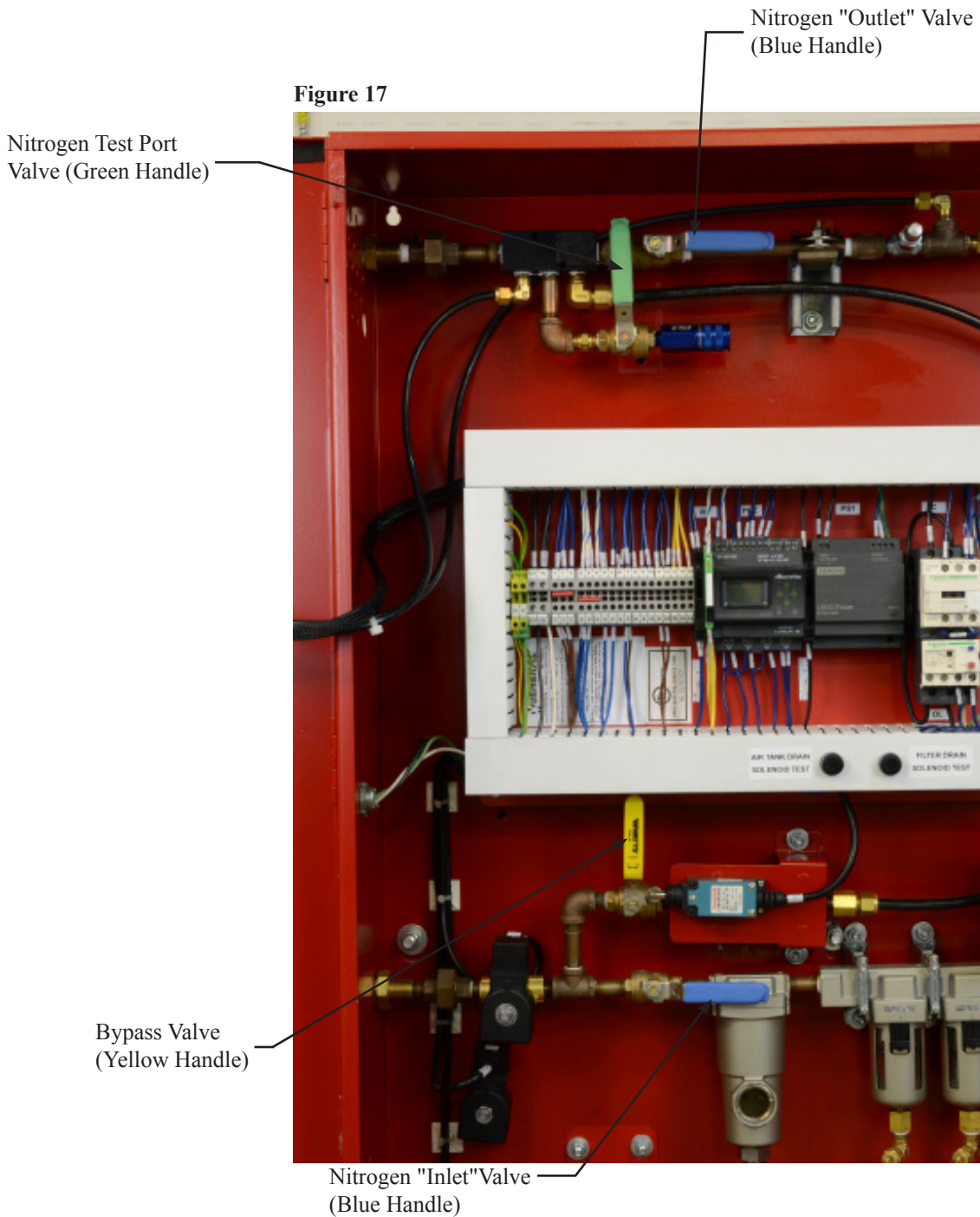

Figure 18

5. Open the petcock on the nitrogen storage tank (bottom tank) and relieve the pressure until the Nitrogen Solenoid light turns ON. See Figure 18. The Nitrogen Solenoid light should turn on at  $60 \pm 3$  PSI on the nitrogen tank pressure gauge.



Nitrogen Storage Tank Petcock

Figure 19

6. The membrane pressure gauge should read between 85 and 105 PSI. See Figure 19.
7. Record the time it takes for the nitrogen storage tank to reach 75 PSI. It should typically take 20 minutes for the NGP-1000D-M1, 14 minutes for the NGP-1000D-M2, and 8 minutes for the NGP-1000D-M3.

**NOTE:** The air compressor will cycle on and off during this process.



- When the nitrogen storage tank pressure reaches  $75 \pm 3$  PSI, the Nitrogen Solenoid light will turn OFF and the nitrogen membrane pressure will go to zero (0). See Figure 20.
- Repeat steps 5-8 a second time to ensure nitrogen storage tank fill up times are consistent.

Figure 20



- On the second cycle, open the Nitrogen Test Port Valve (Green Handle) located on the inside of the cabinet.
- Turn on the Nitrogen Analyzer. See Figure 21. For more information on the Nitrogen Analyzer go to *Nitrogen Analyzer Instructions*. See page 31.
- Attach the Nitrogen Analyzer to the Nitrogen Test Port.
- The nitrogen purity level reading should climb to 98%+. If not go to *Troubleshooting*. See page 21.
- Close the Nitrogen Test Port Valve (Green Handle) and disconnect the Nitrogen Analyzer. Make sure to power off the Nitrogen Analyzer.
- Do not leave the Nitrogen Test Port Valve (Green Valve) open for more than 2 minutes. The purity level may drop and fill times will be lengthened.

Figure 21



- Go to the end of the system where the NGP-SPV or INS-PV was installed. Open the ball valve to allow the units to begin purging. For the NGP-SPV, remove the plug covering the exhaust orifice.
- For INS-PV, press "Start Purge" button. For more information on the INS-PV or if an INS-RA is installed, refer to manual #5401532.
- The system is now in operation.

Figure 22

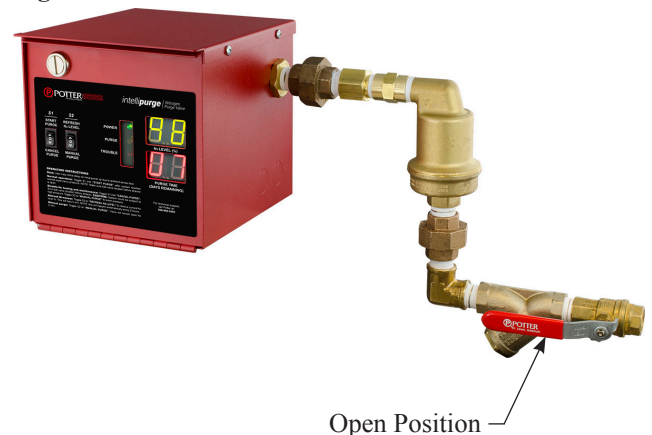

# 10. Nitrogen Control Module

The Nitrogen Control Module is a built in PLC used to control the nitrogen generator and provide useful information on alarms, compressor operating hours, cycles and nitrogen solenoid operation.

Nitrogen Control Module Screen

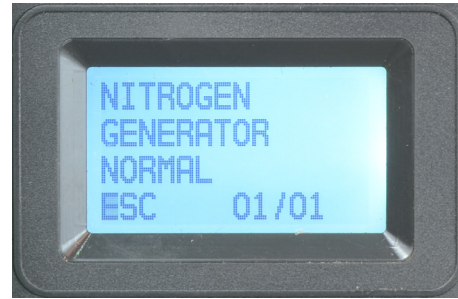

Normal operation does not require any operator input. The display should read “Nitrogen Generator Normal” unless the generator is in alarm or log display mode. To access the panel flip the casing up.

### PLC Operation

To view the log display information:

- Press the Alt Key and then Press the down arrow. Press the Alt Key again.
- Use the UP and DOWN arrow key to scroll through the log screens below.
- To get out of the log press ALT then up arrow, and press ALT again to get to main display.

Compressor Hours and Cycle Screen



Nitrogen Solenoid Hours and Cycle Screen

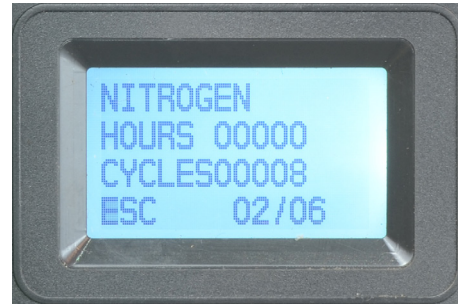

Alarm 1 and 2 Counts Screen

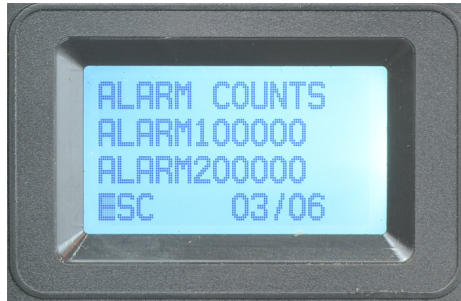

Alarm 3 and 4 Counts Screen

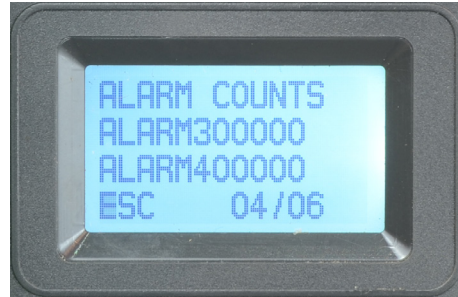

Alarm 5 and 6 Counts Screen



Alarm 7 Counts Screen

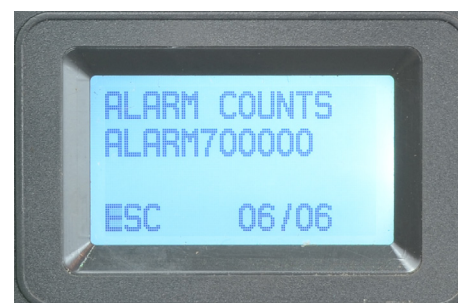

# 11. Nitrogen Generator Alarms/Troubleshooting

The nitrogen generator has 7 alarms. If an alarm is activated, the alarm light will turn red on the outside of the cabinet and the Alarm Horn will sound. The alarm number will also display on the Nitrogen Control Module inside the cabinet.

Figure 23

Alarm Horn  
Silencer



To clear alarms, cycle power or press ALT then hold the right arrow key for 5 seconds. Press ALT again to get back to main menu. There is also a silence button on the back of the Alarm Horn.

### Alarm 1 – Nitrogen Solenoid Excess Cycles

Issue: The nitrogen solenoid has cycled more than 36 times in 12 hours.

**NOTE:** More than 8 cycles a day will reduce membrane life below 10 years.

Answer:

1. If the nitrogen solenoid is ON, check the pressure on the nitrogen storage tank. It should be below 80 PSI. If the pressure is greater than 80 PSI, the pressure switch may need re-adjustment or replacement.
2. Check the nitrogen generator system for leaks. See Page 23 for method.
3. Check the sprinkler system for leaks.

### Alarm 2 – Bypass Alarm

Issue: The nitrogen generator has been left in Bypass Mode (Air Fill) for over 1 hour. This alarm clears when the unit has been placed in Nitrogen Mode. It is designed to prevent the unit from being inadvertently left in Bypass Mode.

Answer:

1. Turn the Bypass Valve (Yellow Handle) to the OFF position. Open the Nitrogen "Inlet" Valve (Blue Handle) and the Nitrogen "Outlet" Valve (Blue Handle). Refer to *Nitrogen Purging Procedure* on page 17.
2. If the unit is filling multiple systems, or being left intentionally in Bypass Mode, mute the Alarm Horn by pressing the button on the inside of the cabinet on the back of the Alarm Horn.

### Alarm 3 – Compressor Overload

Issue: The control panel has tripped due to a motor overload.

Answer:

1. Turn power OFF to the nitrogen generator.
2. Check overload setting.
3. Reset the thermal overload located at the bottom of the compressor contactor. Measure amperage of motor - check for excessive amp draw.

### Alarm 4 – Excessive Air Compressor Run

Issue: The air compressor has run for longer than 45 minutes continuously.

Answer:

1. Check the pressure in the air storage tank. If the pressure is greater than 105 PSI and the compressor is still running it could indicate a pressure switch issue. Call Potter Technical Support at 1-866-956-1211.
2. Check the nitrogen generator system for leaks. See Page 23 for method.

### Alarm 5 – Compressor Fail To Start

Issue: Contactor auxiliary contacts did not close.

Answer:

1. Troubleshoot contactor wiring and functionality. See alarm 4.
2. Replace contactor.

## Alarm 6 – Compressor Excess Cycles

Issue: Air compressor has cycled more than 36 times in 3 hours.

Answer:

1. The unit is running more frequently than normal. Check to ensure all valves in the cabinet are in correct position.
2. Check the nitrogen generator system for leaks. See Page 25 for method.
3. Check the sprinkler system for leaks.

## Alarm 7 – Excessive Nitrogen Solenoid Runtime

Issue: Nitrogen Solenoid has been open for over 6 hours.

Answer:

1. If the Nitrogen Solenoid light is ON, check the pressure on the nitrogen storage tank. The pressure should be below 75±3 PSI. If the pressure is greater than 75±3 PSI, the pressure switch may need re-adjustment or replacement.
2. Check the nitrogen generator system for leaks. See Page 23 for method.
3. Check the sprinkler system for leaks.

## Issue: The air compressor does not turn on.

Answer:

1. Ensure the power disconnect switch is in the ON position and properly wired.
2. Check the pressure gauge on the air storage tank. (Note: The nitrogen generator system will not turn on unless the pressure is below 85±3 PSI.)
3. Make sure all valves are open or closed where necessary.
4. Check for alarms.

## Issue: The air compressor takes too long to fill.

Answer:

1. Confirm all valves are in the correct position. When filling the sprinkler system ensure the Bypass Valve (Yellow Handle) is OPEN. Trying to fill the sprinkler system through the membrane will result in long fill times and possibly damage to the compressor. See Standard *Air Filling Method* for operation on how to fill the sprinkler system starting on page 14.
2. Check the nitrogen generator system for leaks. See page 23 for method.
3. Check the sprinkler system for leaks.

## Issue: The purge valve is not purging.

Answer:

1. Confirm the ball valve is in the open position and the plug (for NGP-SPV only) is removed.
2. Check to ensure the Nitrogen Purge Valve was installed horizontal and level. The Nitrogen Purge Valve contains a float valve that will be closed if the unit is installed improperly.
3. Refer to the bulletin for Nitrogen Purge Valve instructions.

## Issue: There is water in my drain hose.

Answer:

1. Press the Filter Drain Solenoid Test Button on the inside of the cabinet to test if the drain is working.

## Issue: Nitrogen membrane pressure is lower than 80 PSI (when the Nitrogen Solenoid light in ON).

1. Ensure all the ball valves are in the correct position for Nitrogen Mode, go to *Nitrogen Purging Procedure*. See page 17.
2. Adjust the needle valve on the inside of the cabinet to 98% nitrogen. See Figure 24.  
**NOTE:** Nitrogen storage tank needs to be at 60±3 PSI when adjusting needle valve. Also, the air storage tank should be above 80 PSI.
3. Check membrane pressure. It should be between 85 and 105 PSI.
4. Close Nitrogen Test Port Valve (Green Handle).

Figure 24

Needle Valve

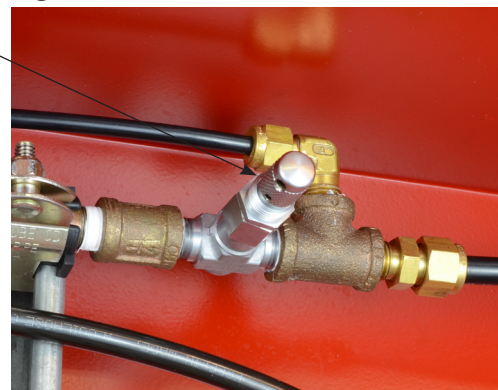

## 12. Nitrogen Generator Leak Check Method

1. First isolate the nitrogen generator from the fire protection system, by closing the ball valve located on the outlet of the nitrogen storage tank. If no ball valve was installed, close the AMD valves installed between the sprinkler system and the nitrogen generator.
2. Record the time the nitrogen generator was isolated and the sprinkler system supervisory pressure. This will be used to determine if there is a leak on the sprinkler system side.
3. Power OFF the nitrogen generator.
4. In the cabinet, open the Bypass Valve (Yellow Handle).
5. Close the Nitrogen "Inlet" Valve (Blue Handle) and the Nitrogen "Outlet" Valve (Blue Handle).
6. Close the Nitrogen Test Port Valve (Green Handle).
7. Exhaust all the gas by using the petcock on the bottom of the air storage tank.
8. Exhaust all the gas by using the petcock on the nitrogen storage tank.
9. Power ON the nitrogen generator. The Power On light on the outside of the cabinet should turn green.
10. Allow the pressure in the air storage tank and the nitrogen storage tank to rise. The green Nitrogen Solenoid light should be ON.
11. Once the air compressor and Nitrogen Solenoid light have both turned off, record the pressure on the air storage tank and the nitrogen storage tank.
  - a. This should typically take 7 minutes for the NGP-1000D-M1/M2/M3
12. Let the nitrogen generator sit for 30 minutes. The air compressor or the Nitrogen Solenoid light should NOT turn on during this time.
13. Recheck the air storage tank and nitrogen storage tank pressures. The pressure should not change.
  - a. If there is a pressure drop the nitrogen generator has a leak. Soap the fittings in the unit and retighten any fittings that are loose.
  - b. If there is no pressure drop, this indicates there is a leak on the sprinkler system side. Return to the sprinkler system to see if there has been a pressure drop on the system during troubleshooting. Fix sprinkler leaks before putting the nitrogen generator back into service.

## 13. Air Side Leak Check Method

1. First isolate the nitrogen generator from the fire protection system, by closing the ball valve located on the outlet of the nitrogen storage tank. If no ball valve was installed, close the AMD valves installed between the sprinkler system and the nitrogen generator.
2. Record the time the nitrogen generator was isolated and the sprinkler system supervisory pressure. This will be used to determine if there is a leak on the sprinkler system side.
3. Power OFF the nitrogen generator.
4. Isolate the Air Side section by closing both the Bypass Valve (Yellow Handle) and the Nitrogen "Inlet" Valve (Blue Handle).
5. Exhaust all the gas by using the petcock on the bottom of the air storage tank. The air storage tank pressure gauge should read zero (0).
6. Power the nitrogen generator ON. The Power On light should be green.
7. Allow the pressure to build to 105±3 PSI. Make note the time it takes to reach this pressure.
  - a. This should typically take less than 5 minutes for the NGP-1000D-M1/M2/M3.
8. If the unit reaches 105±3 PSI and does not stop, this could indicate a pressure switch issue. Call Potter Technical Support at 1-866-956-1211.
9. If the unit reaches 105±3 PSI and stops:
  - a. Record the exact pressure.
  - b. Allow the system to sit for 30 minutes. Recheck the pressure gauge to see if the unit has lost any pressure.
  - c. If pressure is lost, soap piping connections and retighten any loose fittings.
  - d. If no pressure is lost, go to *Nitrogen Generator Leak Check Method*. See page 23.
  - e. If the unit reaches 105±3 PSI and stops but it took longer than 5 minutes for the NGP-1000D-M1/M2/M3 and no leaks are found contact Potter Technical Support at 1-866-956-1211.
10. If the unit cannot reach 105±3 PSI, soap unit for leaks. If no leaks are found call Potter Technical Support at 1-866-956-1211.



## 14. Nitrogen Membrane Check

1. First isolate the nitrogen generator from the fire protection system, by closing the ball valve located on the outlet of the nitrogen storage tank. If no ball valve was installed, close the AMD valve installed between the sprinkler system and the nitrogen generator.
2. Record the time the nitrogen generator was isolated and the sprinkler system supervisory pressure. This will be used to determine if there is a leak on the sprinkler system side.
3. Close the Bypass Valve (Yellow Handle).
4. Open the Nitrogen "Inlet" Valve (Blue Handle) and the Nitrogen "Outlet" Valve (Blue Handle).
5. Exhaust the gas in the nitrogen storage tank by using the petcock on the bottom of the tank until the nitrogen storage pressure is  $60\pm 3$  PSI and the Nitrogen Solenoid light turns ON.
6. Quickly close the petcock.
7. Record the time it takes for the Nitrogen Solenoid light to turn off.
  - a. For the NGP-1000D-M1 this should typically take 20 minutes
  - b. For the NGP-1000D-M2 this should typically take 14 minutes.
  - c. For the NGP-1000D-M3 this should typically take 8 minutes.
8. Check the membrane pressure gauge, it should be between 85-105 PSI.
9. Open the Nitrogen Test Port Valve (Green Handle).
10. Using a portable nitrogen analyzer check the nitrogen purity. The purity should read 98% or greater when the pressure in the nitrogen storage tank reads at least  $60\pm 3$  PSI.

## 15. Sprinkler System Leak Check

If no leak could be found in the nitrogen generator and the unit reaches its desired pressures in the allotted time, this indicates the sprinkler system has a leak larger than the unit can handle in nitrogen generating mode. Isolate the fire sprinkler system and see if the pressure drops. Nitrogen generators are designed for 1.5 PSI leak over 24 hours per NFPA 13's new system leak rate, unless specified otherwise.

To keep system in service the unit can run in Bypass Mode while arrangements are made to fix sprinkler system leaks. Note the unit will alarm if left in Bypass Mode for longer than 1 hour. This can be silenced by pressing the button on the back of the Alarm Horn. A LED will light on the back of the Alarm Horn. If the alarm is reset, the light will go out, and the Alarm Horn will sound if another alarm occurs.

## 16. NGP-1000D-M1/M2/M3 Maintenance

### ⚠ WARNING

All pressure must be relieved from the entire nitrogen generator system BEFORE servicing. To avoid system damage and/or personal injury, the nitrogen generator should be isolated from the compressed air supply and the generator system fully depressurized before any maintenance or service is performed. All maintenance and troubleshooting activities for the Potter Nitrogen Generator should be performed by qualified personnel using reasonable care. Before servicing, isolate all risers by closing all AMD valves and relieving all system pressure from the Potter Nitrogen Generator. Failure to do so could result in serious injury or death.

The Potter Nitrogen Generator features durable components and construction for long-lasting value, reliable performance, and require little maintenance.

Schedule Maintenance Table	
Part	Frequency
5 Micron & Coalescing Filters	Annually
Nitrogen Purity Analyzer	Sensor Battery as Required
Pressure Settings	Inspected Quarterly

Air Compressor Maintenance Schedule	
Weekly	<ul style="list-style-type: none"> <li>• Drain condensate from receiver and traps</li> <li>• Check for unusual noise or vibration</li> <li>• Clean air filters (only with non-petroleum based products)</li> <li>• Clean all external parts of the compressor and motor</li> </ul>
Monthly	<ul style="list-style-type: none"> <li>• Manually test safety relief valve</li> <li>• Inspect air system for leaks</li> <li>• Tighten fittings, nuts and screws as required</li> </ul>
Quarterly	<ul style="list-style-type: none"> <li>• Change Intake filter element</li> </ul>

Replacement Parts	
Part	Replacement Part Number
NGP-MK2 MAINTENANCE KIT NGP-250D/500D/M1	1119543
NGP-MK MAINTENANCE KIT NGP-M2-M5	1119785
NGP-AMD-1 AIR MAINTENANCE DEVICE	1119787
NGP-PSN2 NITROGEN ANALYZER	1119796
SENSOR ELEMENT F/NGP	5340014
BATTERY F/NGP NITROGEN SENSOR	5130098
NGP-VAK-30 VIBRATION KIT	1119477
OIL-LESS MINOR REPAIR KIT(1 PER CYL)	1119549
CYLINDER REPAIR KIT (1 PER CYL)	1119550
N2 SOLENOID VALVE	1119551
OIL-LESS COMPRESSOR INTAKE FILTER ELEMENT (1 PER CYL)	1119552
NGP-M1-MEMBRANE-500D & 1000D-M1	1119554
NGP-M2-MEMBRANE	1119555
NGP-M3-MEMBRANE	1119556

## Filter Replacement

To replace the filters in the generator cabinet:

1. Isolate the nitrogen generator and relieve pressure.
2. Disconnect the power to the nitrogen generator.
3. Unscrew the bowl from the filter body by pushing the black lever down and twisting. This can be done without disconnecting the drain line. See Figure 25.
4. Remove the element by unscrewing the filter. See Figure 26.
5. Clean the filter body and bowl with a clean rag.
6. Replace the filter elements using filters provided in the replacement kit.
7. Check for leaks.

Figure 25



Figure 26

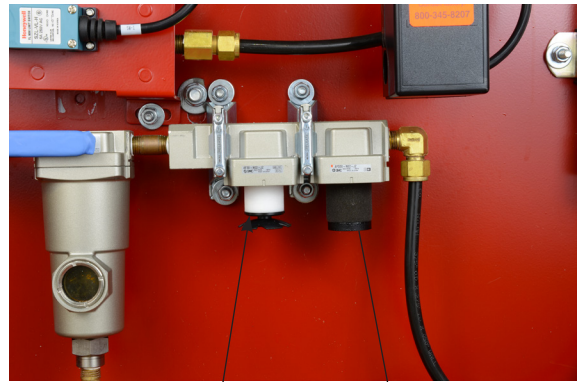

5 Micron Filter

Coalescing Filter

## Air Compressor Replacement

1. Isolate the nitrogen generator and relieve pressure.
2. Disconnect the power to the nitrogen generator.
3. Disconnect wires in junction box on the air compressor.
4. Loosen union after flex hose on compressor discharge.
5. Remove flex hose from compressor discharge.
6. Remove bolts holding compressor to rubber isolation mounts (4). See Figure 27.
7. Install new air compressor.
8. Verify wiring in motor junction box corresponds to the input voltage.
9. Power the generator.
10. Check for leaks.

Figure 27

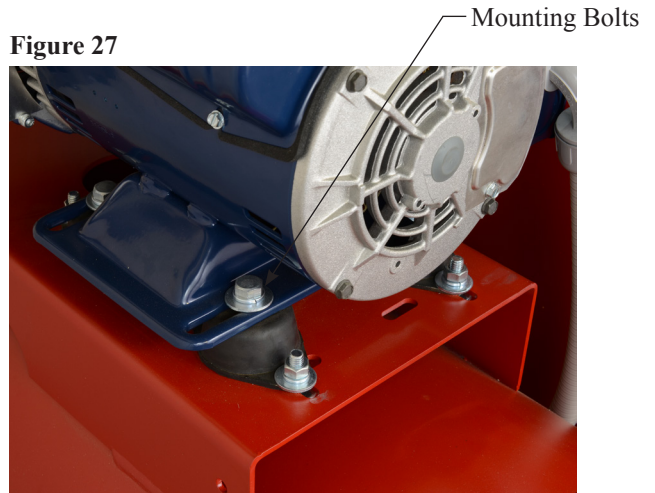

## 17. Normal Operating Parameters of NGP-1000D-M1/M2/M3

The Potter Nitrogen Generator System uses a two tank system design to deliver high purity nitrogen to the fire protection system. The pressure switch on the air storage tank controls the air compressor by turning it on and off at the desired pressure set points. Another pressure switch on the nitrogen tank controls the nitrogen solenoid valve on the inside of the cabinet. Whenever the nitrogen storage tank requires nitrogen, the nitrogen solenoid valve opens allowing air to come from the air storage tank. Once the nitrogen storage tank reaches the desired set point the nitrogen solenoid closes.

- Periodic (typically less than 10 times an hour) running of the air compressor is expected.
- Periodic (typically less than 12 times a day) opening and closing of the nitrogen solenoid is expected.
- When the nitrogen solenoid valve is closed, the membrane pressure gauge will read “0”.
- The automatic drain valve automatically releases condensate from the unit.

**NOTE:** These are typical durations. Actual times may be slightly longer or shorter. These are typical pressure set points. Actual pressure can be  $\pm 3$  PSI.

Operational State	NGP-1000D-M1	NGP-1000D-M2	NGP-1000D-M3	Recorded Parameter
Air Compressor OFF Pressure	105 PSI	105 PSI	105 PSI	
Air Compressor ON Pressure	85 PSI	85 PSI	85 PSI	
Time Interval to build pressure from 85 PSI to 100 PSI in air storage tank	1 minute	1 minute	1 minute	
Nitrogen Solenoid OFF Pressure (Nitrogen Tank Pressure)	75 PSI	75 PSI	75 PSI	
Nitrogen Solenoid ON Pressure (Nitrogen Tank Pressure)	60 PSI	60 PSI	60 PSI	
Time Interval to build pressure from 60 PSI to 75 PSI in air tank storage in Bypass Mode	2 minutes	2 minutes	2 minutes	
Time Interval to build pressure from 60 PSI to 75 PSI in air tank storage in Nitrogen Mode	20 minutes	14 minutes	8 minutes	

## 18. Nitrogen Analyzer Instructions

Component	Description
3 ½ Digit Display	The 3 ½ digit liquid crystal display (LCD) provides direct readout of nitrogen concentrations in the range of 0 - 105.0% (100.1% - 105.0% used for calibration determination purposes). The digits also display error codes and calibration codes as necessary.
Low Battery Indicator	The low battery indicator is located at the top of the display and is only activated when the voltage on the batteries is below a normal operating level.
% Symbol	The “%” sign is located to the right of the concentration number and is present during normal operation.
Calibration Symbol	The calibration symbol is located at the bottom of the display and is timed to activate when a calibration is necessary.
ON/OFF Key	This key is used to turn the device on or off.
Calibration Key	This key is used to calibrate the device. Holding the key for more than three seconds will force the device to enter a calibration mode

### Automatic Calibration

After the unit is turned on, it will automatically calibrate to room air. The display should be stable and reading 79.1%.

To check the nitrogen concentration of a sample gas: (after the unit has been calibrated)

1. Connect the Tygon tubing to the bottom of the analyzer by threading the barbed adapter onto the oxygen sensor.
2. Attach the other end of the sample hose to the sample gas source and initiate flow of the sample to the unit at a rate of 1-10 liters per minute. *2 liters per minute is recommended.*
3. Using the ON/OFF key, make sure the unit is in the power “ON” mode.
4. Allow the nitrogen reading to stabilize. This will take approximately 30 seconds or more.

### Calibrating the N<sub>2</sub> Analyzer

Calibrate the N<sub>2</sub> analyzer upon initial power-up. Thereafter, Maxtec® recommends calibration on a weekly basis. To serve as a reminder, a one week timer is started with each new calibration. At the end of one week a reminder icon appears on the bottom of the LCD. Calibration is recommended if the user is unsure when the last calibration procedure was performed, or if the measurement value is in question.

With compressed air (79.1% N<sub>2</sub>), new calibration is required when:

- The measured N<sub>2</sub> percentage in 79.1% N<sub>2</sub> is above 80.1% N<sub>2</sub>
- The measured N<sub>2</sub> percentage in 79.1% N<sub>2</sub> is below 78.1% N<sub>2</sub>
- The CAL reminder icon is blinking at the bottom of the LCD

A simple calibration may be made with the sensor open to static ambient air.

### Calibration Errors and Error Codes

The nitrogen purity analyzer has a self test feature built into the software to detect faulty calibrations, oxygen sensor failures, and low operating voltage. Refer to the following table for an explanation of error codes and possible actions to take.

Code	Meaning	Corrective Action
E02	No sensor attached	Open the hand held nitrogen purity analyzer and disconnect and reconnect sensor. Unit should perform an auto calibration and should read 79.1%. If not, contact Customer Service for possible sensor replacement.
E02	No valid calibration data available	Make sure unit has reached thermal equilibrium. Press and hold the Calibration Button for three seconds to manually force a new calibration.
E02 or ED4	Battery below minimum operating voltage	Replace batteries.
CAL Err St: O2	Sensor reading not stable	Wait for displayed nitrogen reading to stabilize, when calibrating the device at 100% oxygen. Wait for unit to reach thermal equilibrium (Please note that this can take up to one half hour, if the device is stored in temperatures outside the specified operating temperature range).
CAL Err lo	Sensor voltage too low	Press and hold the Calibration Button for three seconds to manually force a new calibration. If unit repeats this error more than three times, contact Customer Service for possible sensor replacement.
CAL Err hi	Sensor voltage too high	Press and hold the Calibration Button for three seconds to manually force a new calibration. If unit repeats this error more than three times, contact Customer Service for possible sensor replacement.
CAL Err Bat	Battery voltage too low to recalibrate	Replace batteries.

### Changing the Batteries

When the batteries need to be changed, the device will indicate this in one of two ways:

- » The battery icon on the bottom of the display will begin to flash. This icon will continue to flash until the batteries are changed. The unit will continue to function normally for approx. 200 hours.
- » If the device detects a very low battery level, an error code of “E04” will be present on the display, and the unit will not function until the batteries are changed.

To change the batteries, begin by removing the three screws from the back of the device. A #1 phillips screwdriver is required to remove these screws.

Once the screws are removed, gently separate the two halves of the device.

The batteries can now be replaced from the back half of the case. Be sure to orient the new batteries as indicated in the embossed polarity on the back case.

NOTE: If the batteries are installed incorrectly the batteries will not make contact and the device will not operate.

Carefully, bring the two halves of the case together while positioning the wires so they are not pinched between the two case halves. The gasket separating the halves will be captured on the back case half.

Reinsert the three screws and tighten until the screws are snug.

The device will automatically perform a calibration and begin displaying % of oxygen.

HELPFUL HINT: If unit does not function, verify that the screws are tight to allow proper electrical connection.

## Changing the Oxygen Sensor

Should the oxygen sensor require changing, the device will indicate this by presenting “Cal Err lo” on the display after initiating a calibration.

To change the oxygen sensor, begin by removing the three screws from the back of the device. A #1 Phillips screwdriver is required to remove these screws.

Once the screws are removed, gently separate the two halves of the device.

Disconnect the oxygen sensor from the printed circuit board by pressing the unlock lever first and then pull the connector out of the receptacle. The oxygen sensor can now be replaced in the back half of the case.

**HELPFUL HINT:** Be sure to orient the new sensor by aligning the red arrow on the sensor with the arrow in the back case. A small tab is located on the back case that is designed to engage the sensor and prevent it from rotating within the case.

**NOTE:** If the oxygen sensor is installed incorrectly, the case will not come back together and the unit may be damaged when the screws are reinstalled.

Reconnect the oxygen sensor to the connector on the printed circuit board.

Carefully bring the two halves of the case together while positioning the wires to ensure they are not pinched between the two case halves. Make sure the sensor is fully inserted and in the proper orientation.

Reinsert the three screws and tighten until the screws are snug. Verify the unit operates properly.

The device will automatically perform a calibration and begin displaying % of oxygen.



# 19. Wiring Diagrams

## Single Phase Models Wiring:

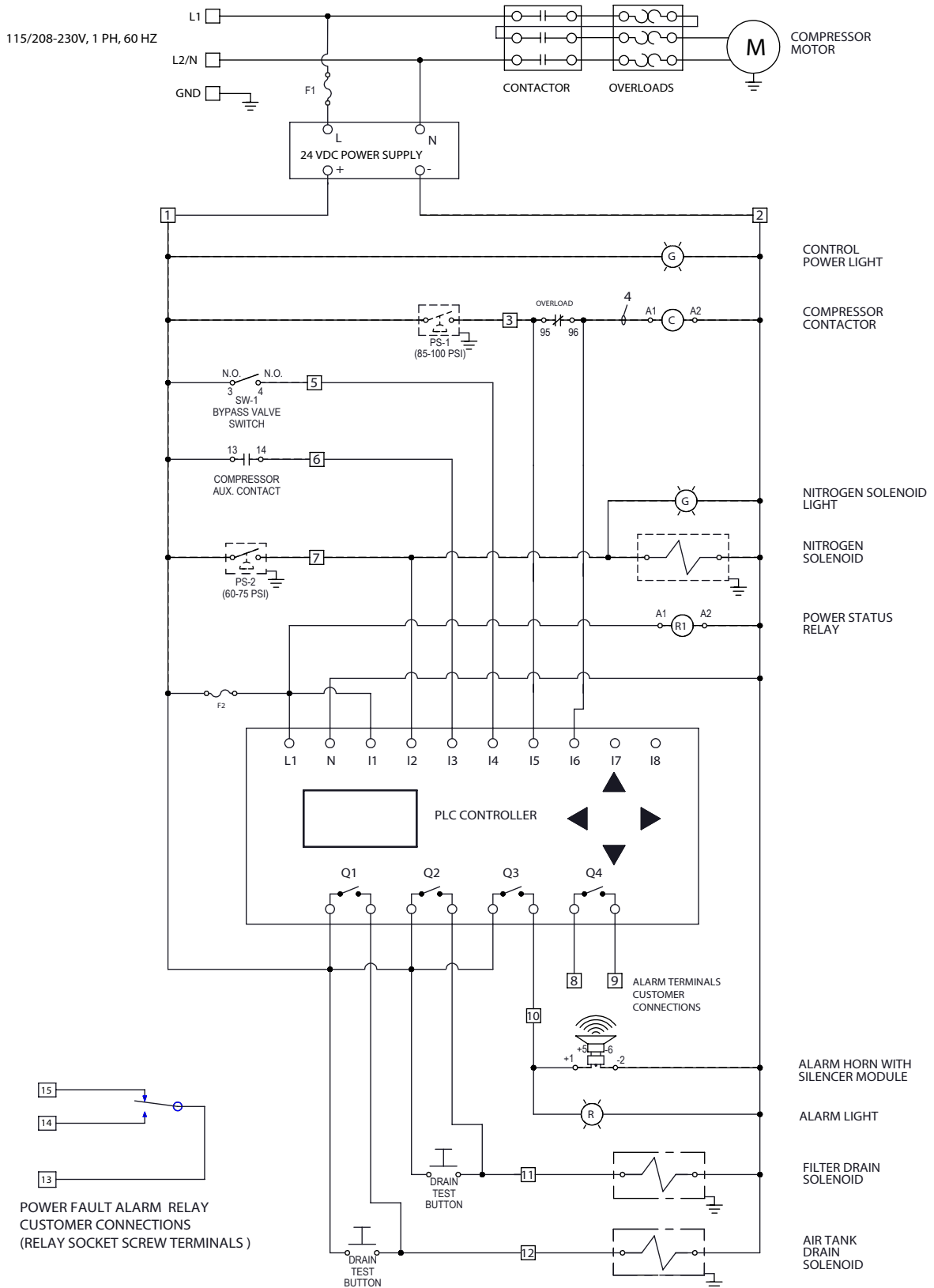

## Three Phase Models Wiring:

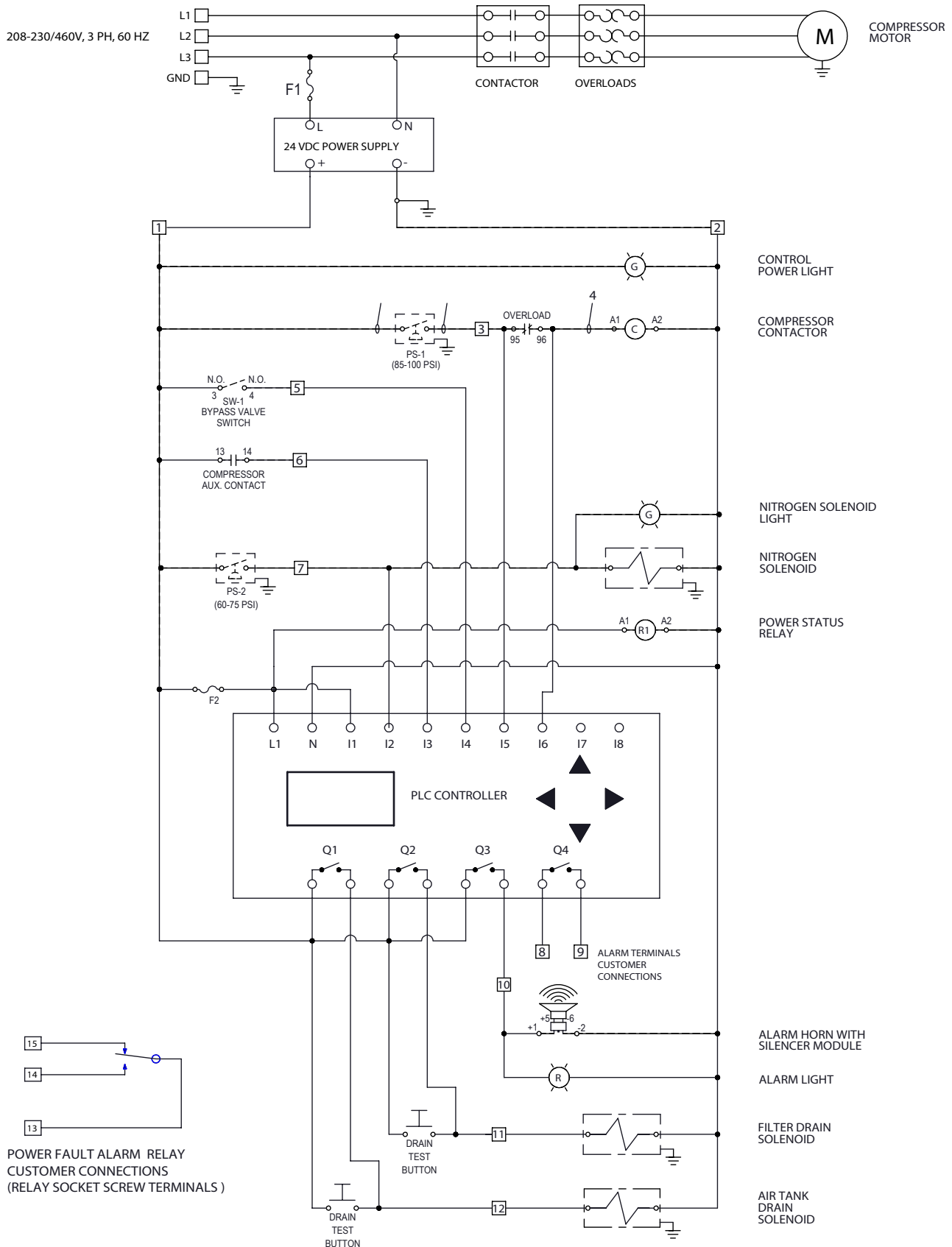

NOTE: GROUND MOTOR, PRESSURE SWITCHES, AND SOLENOID COILS

## 21. Technical Specifications and Drawings

NGP-1000D-M1

Size (HxWxD)	54" x 44" x 32"
Weight	500 lbs
Power Supply	Available in 208V (11.6A), 230V (11A), single phase and 208V (9.2A), 230V (9.2A), 460V (4.6A) three phase
Fire Sprinkler System Connection	½" Female NPT
Mounting Holes	(4) ½" Ø
Max operating Pressure	105 PSI
Temperature Range	50°F (10°C) to 110°F (43°C)
Air Purity	ISO Class 1.4.1 or better: Free of water 38°F (3°C) Dew Point, compressor oil (0.008 PPM or .01 mg/m <sup>3</sup> ), hydrocarbons, and particles (<0.01 µm microns)

NGP-1000D-M2

Size (HxWxD)	62" x 44" x 33"
Weight	550 lbs
Power Supply	Available in 208V (11.6A), 230V (11A), single phase and 208V (9.2A), 230V (9.2A), 460V (4.6A) three phase
Fire Sprinkler System Connection	½" Female NPT
Mounting Holes	(4) ½" Ø
Max operating Pressure	105 PSI
Temperature Range	50°F (10°C) to 110°F (43°C)
Air Purity	ISO Class 1.4.1 or better: Free of water 38°F (3°C) Dew Point, compressor oil (0.008 PPM or .01 mg/m <sup>3</sup> ), hydrocarbons, and particles (<0.01 µm microns)

NGP-1000D-M3

Size (HxWxD)	62" x 44" x 33"
Weight	550 lbs
Power Supply	Available in 208V (11.6A), 230V (11A), single phase and 208V (9.2A), 230V (9.2A), 460V (4.6A) three phase
Fire Sprinkler System Connection	½" Female NPT
Mounting Holes	(4) ½" Ø
Max operating Pressure	105 PSI
Temperature Range	50°F (10°C) to 110°F (43°C)
Air Purity	ISO Class 1.4.1 or better: Free of water 38°F (3°C) Dew Point, compressor oil (0.008 PPM or .01 mg/m <sup>3</sup> ), hydrocarbons, and particles (<0.01 µm microns)

## NGP-1000D-M1

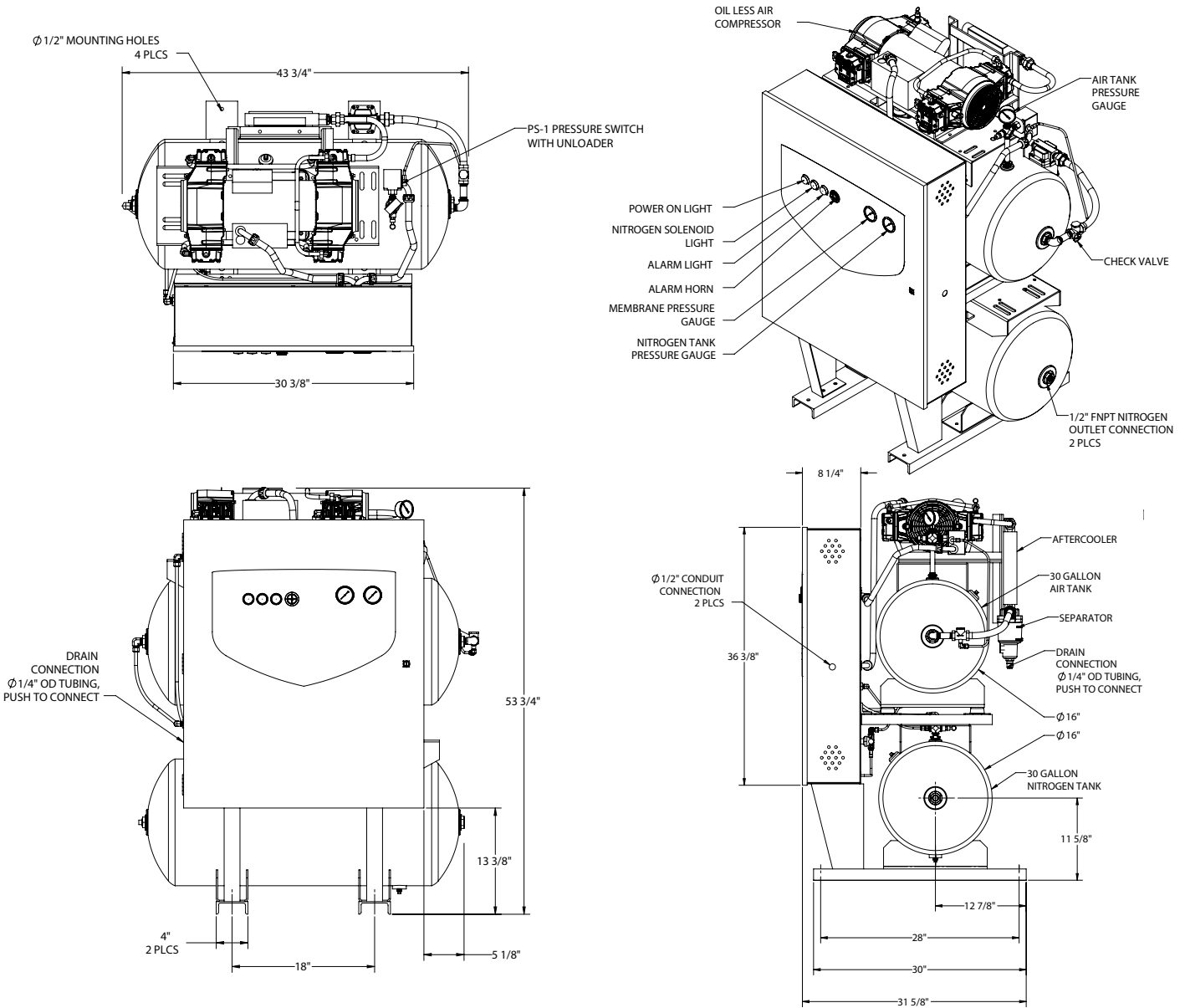

## NGP-1000D-M2

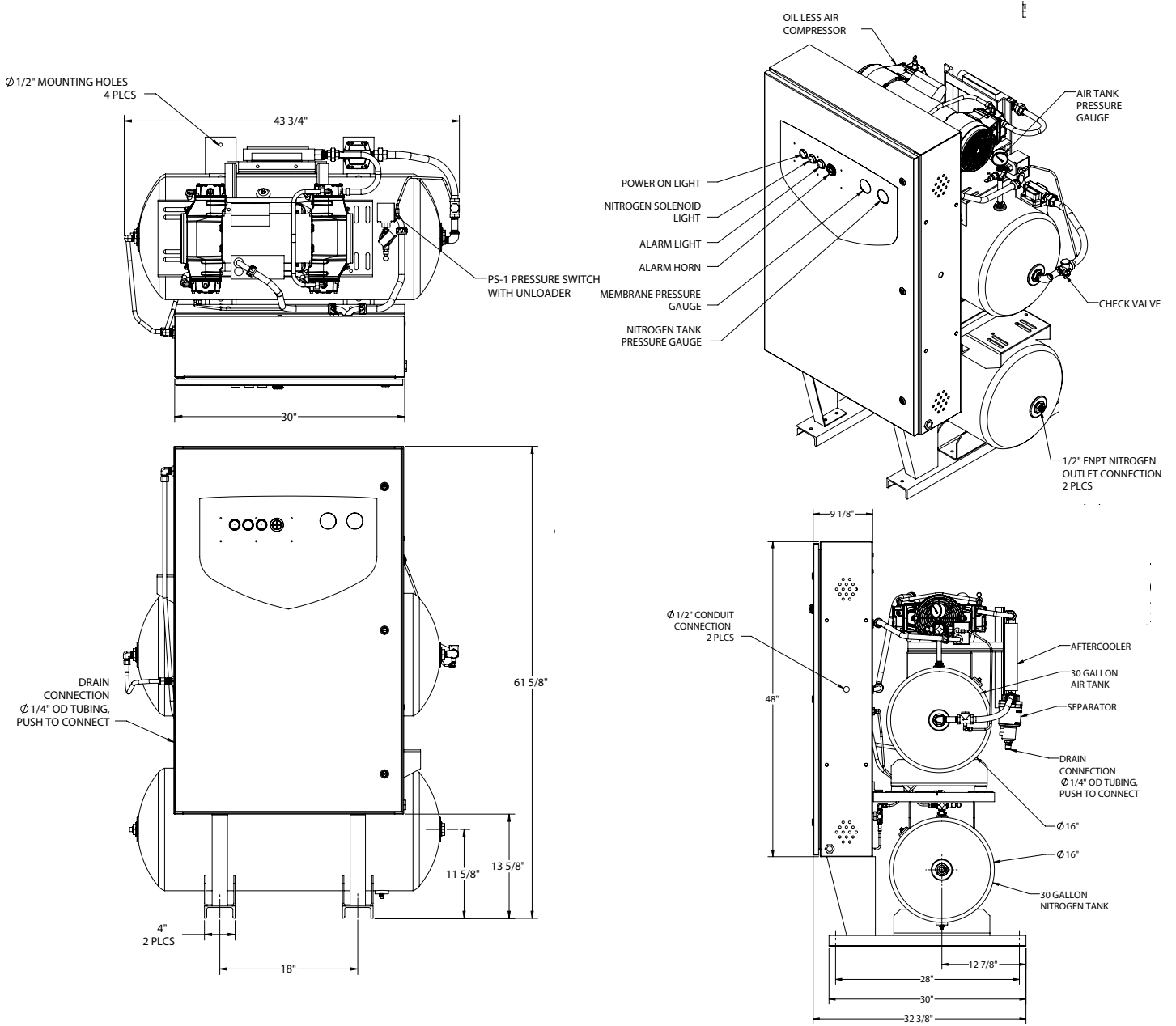

## NGP-1000D-M3

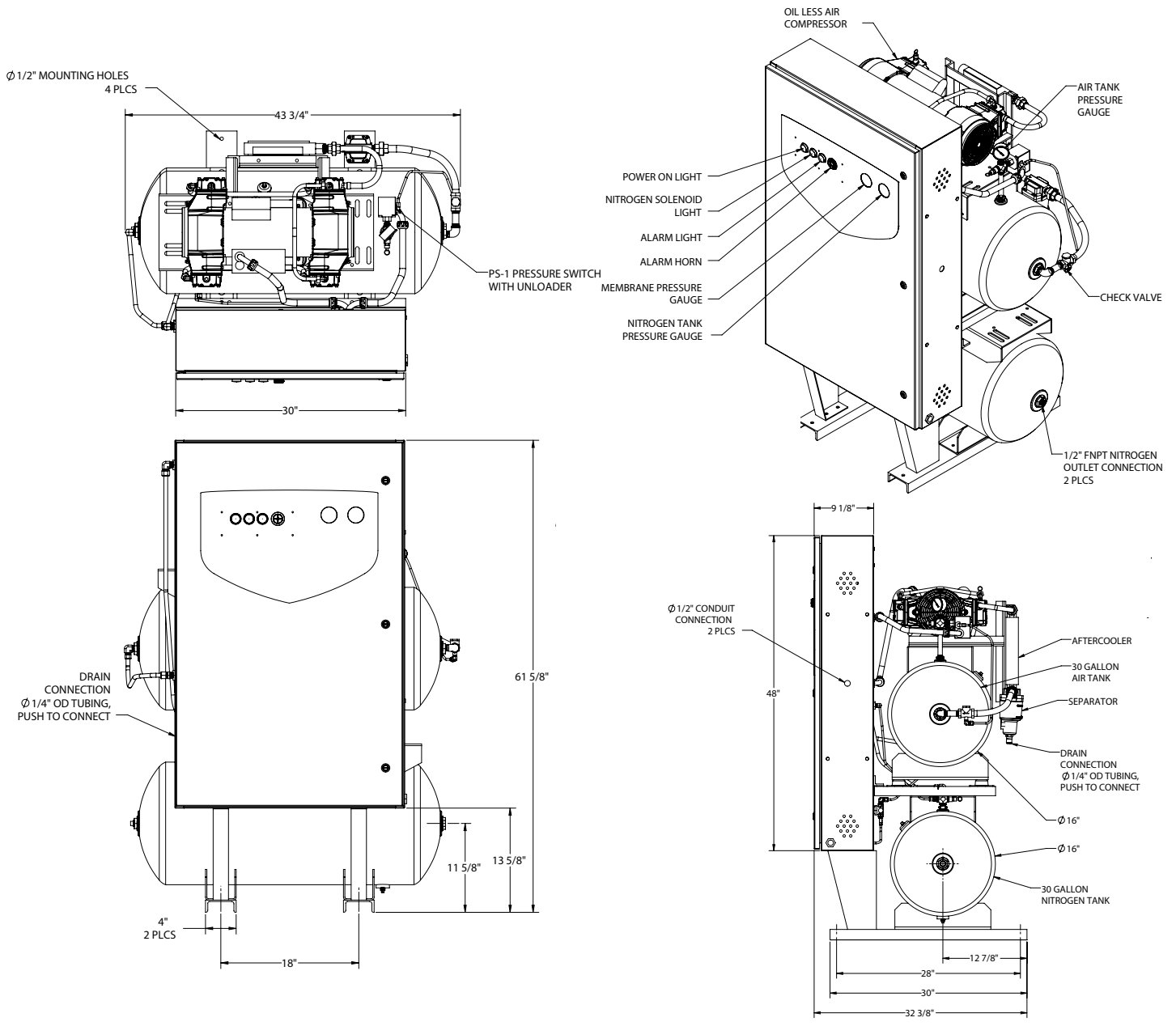

## 21. Warranty

### GENERAL PROVISIONS & LIMITATIONS

Potter Electric Signal Company, LLC (the “Company”) warrants to each original purchaser (“Purchaser”) of its new products from the Company or its Authorized Distributor that such products are, at the time of delivery to the Purchaser, made with good materials and workmanship. No warranty is made with respect to:

1. Any product, which has been repaired or altered in such a way, in the Companies judgment, as to affect the product adversely.
2. Any product, which has, in the Companies judgment been subjected to negligence, accident, improper storage, improper installation or application.
3. Any product, which has not been operated or maintained in accordance with the recommendations of the Company.
4. Components or accessories manufactured, warranted and serviced by others.
5. Any reconditioned or prior owned product.

Claims for items described in 4 above should be submitted directly to the manufacturer.

### WARRANTY PERIOD

The Company’s obligation under this Warranty is limited to repair or, at its option, replacing during normal business hours at the designated facility of the Company, any part that in its judgment proved not to be as warranted within the applicable Warranty Period as follows.

### COMPONENTS

All non-consumable components are warranted for 12 months from the date of purchase. Consumable are not covered under warranty. The unit must have been installed by either a factory authorized distributor or agent in accordance with the factory recommendations taking into account all other local site conditions not originally noted to the factory. The unit must be operated and maintained in accordance with the Factory recommendations and original design conditions. Failure to provide such proof of the above may void warranty.

### LABOR TRANSPORTATION & INSPECTION

The Company will repair or replace any product or part thereof which in the Companies judgment is proved to be not as warranted. Labor costs are not covered under warranty.

All costs of transportation of product, labor or parts claimed not to be as warranted and, of repaired or replaced parts to or from factory shall be borne by purchaser. The Company may require the return of any part claimed not to be as warranted to one of its facilities as designated by the Company, transportation prepaid by Purchaser, to establish a claim under this warranty.

Replacement parts provided under the terms of the warranty are warranted for the remainder of the Warranty Period of the product upon which installed to the same extent as if such parts were original components.

### DISCLAIMER

THE FOREGOING WARRANTY IS EXCLUSIVE AND IT IS EXPRESSLY AGREED THAT, EXCEPT AS TO TITLE, THE COMPANY MAKES NO OTHER WARRANTIES, EXPRESSED OR IMPLIED OR STATUTORY, INCLUDING ANY IMPLIED WARRANTY OR MERCHANTABILITY.

THE REMEDY PROVIDED UNDER THIS WARRANTY SHALL BE THE SOLE, EXCLUSIVE AND ONLY REMEDY AVAILABLE TO THE PURCHASER AND IN NO CASE SHALL THE COMPANY BE SUBJECT TO ANY OTHER OBLIGATIONS OR LIABILITIES. UNDER NO CIRCUMSTANCES SHALL THE COMPANY BE LIABLE FOR SPECIAL, INDIRECT, INCIDENTAL OR CONSEQUENTIAL DAMAGES, EXPENSES, LOSSES OR DELAYS HOWSOEVER CAUSED.

No statement, representation, agreement, or understanding, oral or written, made by any agent, distributor, representative or employee of the Company which is not contained in this Warranty will be binding upon the company unless made in writing and executed by an officer of the Company.

This warranty shall not be effective as to any claim which is not presented within 30 days after the date upon which the product is claimed not to have been as warranted. Any action for breach of this warranty must be commenced within one year after the date upon which the cause of action occurred.

Any adjustment made pursuant to this warranty shall not be construed as an admission by the Company that any product was not as warranted.

### PROMPT DISPOSITION

The Company will make a good faith effort for prompt correction or other adjustment with respect to any product, which proves to be defective within the warranty period. Before returning any product, write or call the distributor, agent or authorized company from which the product was purchased, describing defect and giving date and number of original invoice, as well as proof of Factory supplied consumable and proof of scheduled maintenance. Title and risk of loss pass to buyer upon delivery to the common carrier.

### PRODUCT SUITABILITY

Many States, Localities and Countries have codes and regulations governing sales, construction, installation, and/or use of products for certain purposes, which may vary from those in neighboring areas. While Potter attempts to assure that its products comply with such codes, it cannot guarantee compliance, and cannot be responsible for how the product is installed or used. Before purchase and use of a product, please review the product application, and national and local codes and regulations, and be sure that the product, installation, and use will comply with them.