

PSN-1000 & PSN 1000(E) Installation Manual



Potter Electric Signal Company, LLC

St. Louis, MO

Customer Service: (866) 240-1870 • Technical Support: (866) 956-1211 • Fax: (314) 595-6999

www.pottersignal.com

Document 5403599-Rev. E.-07/22

1. Installation Wiring Document

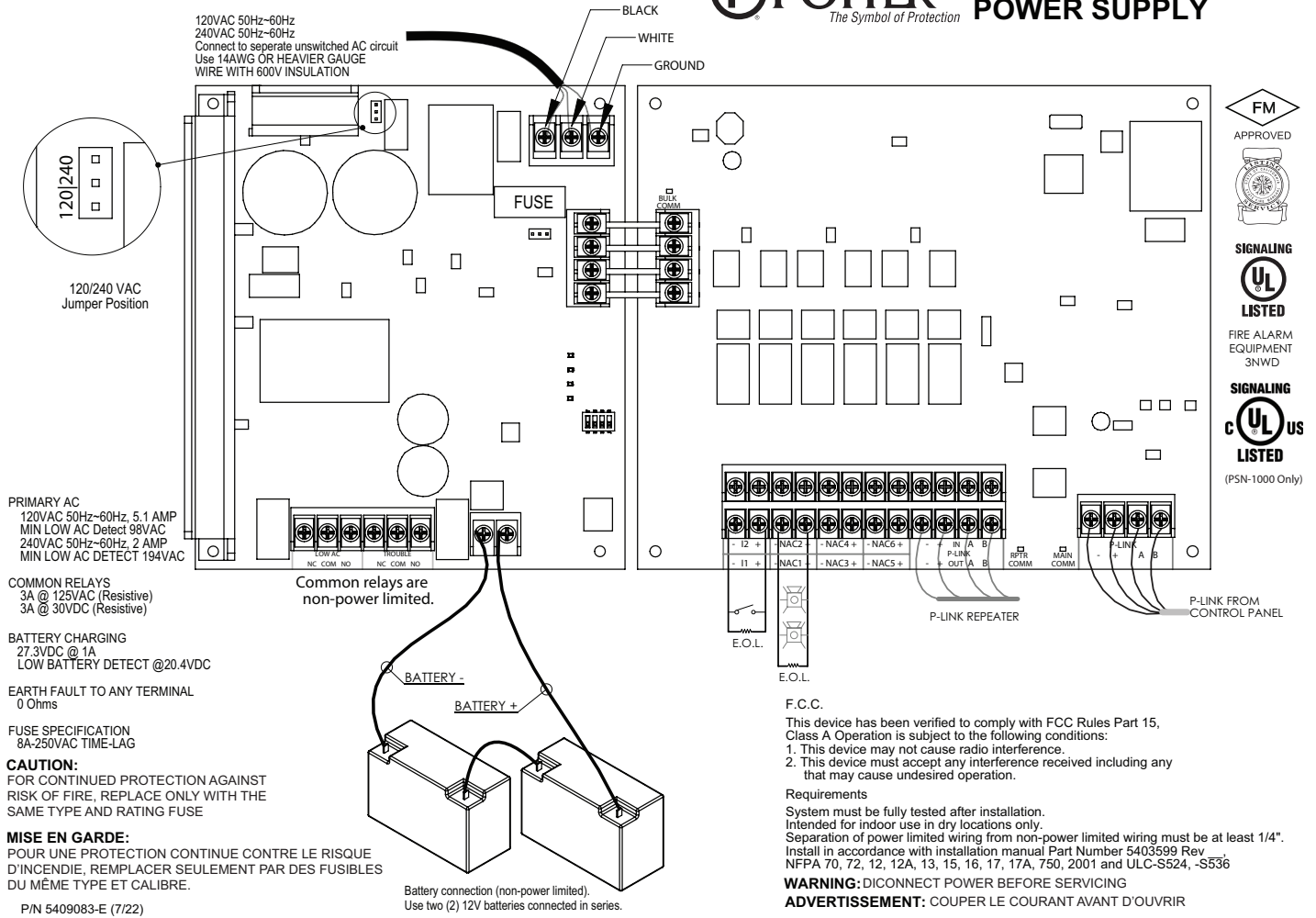

Main Supply Circuit

The AC terminals are located on the power supply board. The power supply board supervises the main AC power and provides indication that the AC power is absent.

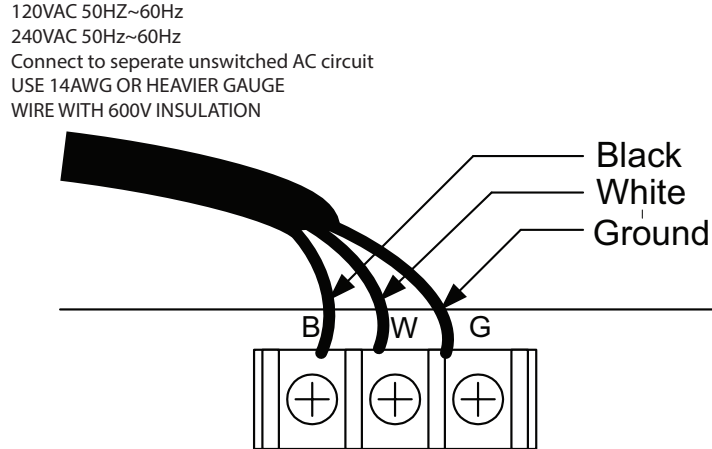

Figure 1

The terminals are rated at 120 VAC/240 VAC 50/60 Hertz and are marked so accordingly on the board. The earth ground connection is marked as “G” and is the furthest connection from the line voltage connection.

The AC input power ratings:

Maximum of 5.1A at the nominal 120 VAC rating.

Maximum of 3A at the nominal 240 VAC rating.

Rechargeable Battery Circuit

The battery charging circuit is provided on the power supply board. Terminal connections are provided to connect wire leads for battery connection. The battery must be a recognized or listed sealed lead acid battery or equivalent.

The battery charging voltage is approximately 27.3 VDC and the circuit is supervised. The battery circuit is protected with a non-replaceable 7 amp poly switch located on the main circuit board. The maximum battery charging current is 1.0 amp DC.

The battery circuit is rated for 8 to 55 AH batteries and the cabinet will house up to two 18 AH batteries. The batteries will operate the panel for at least 24 hours and 5 minutes of alarm. In order to determine the minimum size batteries for standby and alarm times desired, the installer must complete a battery calculation work sheet in order to determine the minimum battery size for a particular application. For reference, the battery calculation work sheet is attached as Appendix A. Complete standby battery calculations must be completed to ensure adequate battery sizes are provided.

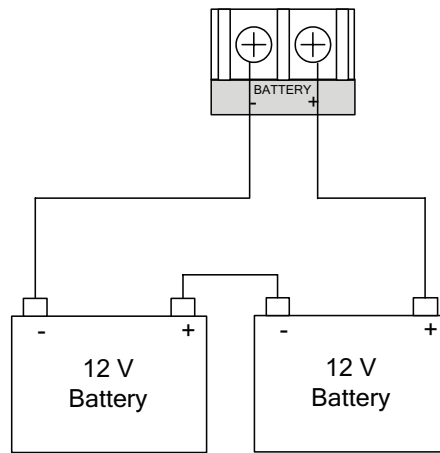

Figure 2

Separation of Circuits - Power Limited, Non-Power Limited, High Voltage Wiring

The main AC power connection is considered high-voltage and non-power limited. Battery conductors, and the alarm, supervisory, and trouble relays are non-power limited. All remaining circuits are low-voltage, power limited connections.

Proper separation must be maintained between the circuits listed above. All separations in the different wiring must be maintained by at least 0.25 inches and the wire insulation must be for the higher voltage.

In the enclosure there are sufficient knock outs located around the periphery of the cabinet to allow the installer to maintain separation between power limited and non-power limited connections. The main AC power connection should be made on the left side or top left of the cabinet.

Notification Appliance Circuits (NACs)

The PSN-1000 is equipped with six NAC circuits. Each of the circuits is rated for a continuous 3 amps at 24 VDC. The outputs are supervised and regulated. The NACs reverse polarity upon activation and the board and illustrations are marked accordingly.

The NAC circuits can be configured for Class A operation. Class-A operation is accomplished by using a pair of NAC circuits. Therefore, the PSN-1000 can provide 3 Class A circuits, each rated for a continuous 3 amps at 24 VDC. The outputs are supervised and regulated.

NAC circuits are power limited and the type of output is selectable. The NACs may be configured for strobe synchronization with Potter/AMSECO, Wheelock, Gentex, or System Sensor strobe devices as shown compatible in this document and the installation instructions.

The maximum impedance is a function of the load being applied to the circuit. In order to calculate the maximum impedance as follows

(Alarm Current of Notification Appliances) X (Wire Resistance) < 3 volts.

The NAC circuits may be configured for Class A, or Class B.

The panel has ground fault detection on the NAC circuits. The impedance to ground for ground fault detection is 0 ohms.

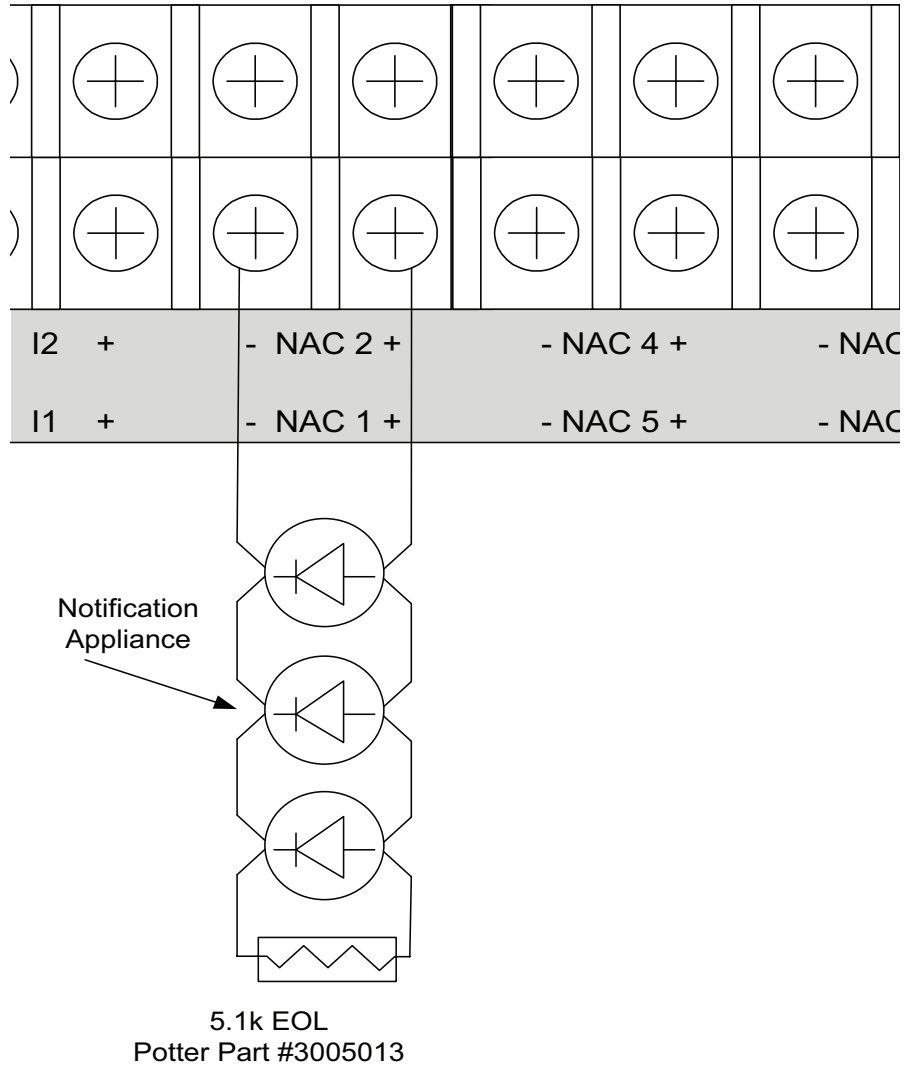

Figure 3 (Class B NAC)

The end of line resistor is a 5.1K ohm resistor. The resistor assembly has been evaluated in past projects and is a standard in the Potter panel product line. The Potter part number for the listed end of line assembly is 3005013 EOL Resistor Assembly and 3002182 EOL Plate Assembly.

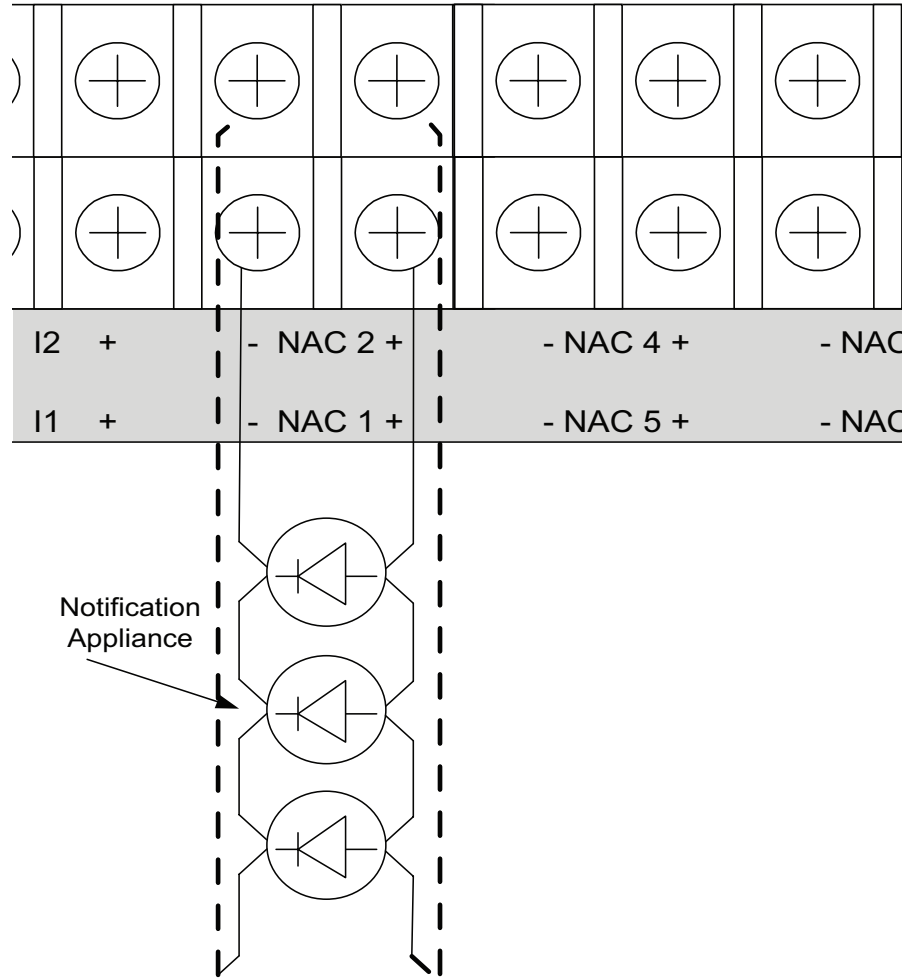

Figure 4 (Class A NAC)

Class A operation requires that two NAC circuits be utilized as shown in Figure 4. Up to 3 Class A circuits can be configured by pairing NAC 1&2, NAC 3&4 and NAC 5&6.

Input Circuits

The panel is equipped with two input circuits, I1 and I2. These circuits are dry-contact monitoring inputs, and can be used in class B mode only. I1 and I2 are low voltage, power limited, and supervised.

Maximum wiring resistance = 100 ohms.

Maximum wiring capacitance = 1 uF.

Maximum wire length = 10,000 feet.

Maximum IDC voltage = 24 VDC

Maximum IDC current = 15 ma

The panel has ground fault detection on the input circuits. The impedance to ground for ground fault detection is 0 ohms.

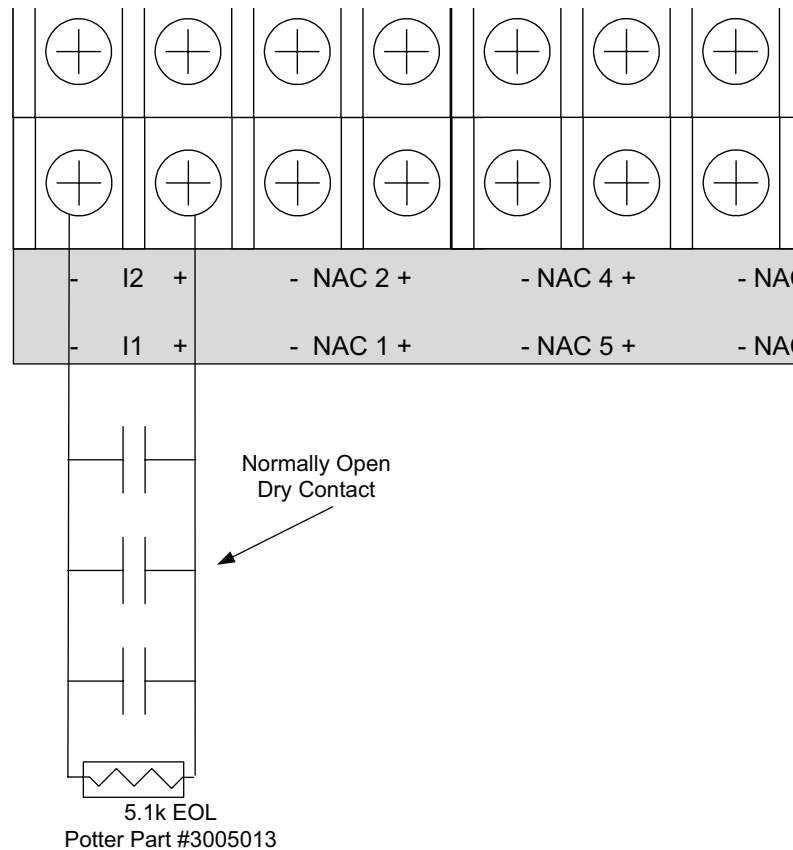

Figure 5 (Input Circuit as Class B Dry Contact Input)

The end of line resistor is a 5.1K ohm resistor. The resistor assembly has been evaluated in past projects and is a standard in the Potter panel product line. The Potter part number for the listed end of line assembly is 3005013 EOL Resistor Assembly and 3002182 EOL Plate Assembly.

P-Link from Control Panel

The control panel communicates with the PSN-1000 via the main P-Link circuit. This connection is electrically isolated from the rest of the PSN-1000. All supervision of the PSN-1000 is conducted through this connection.

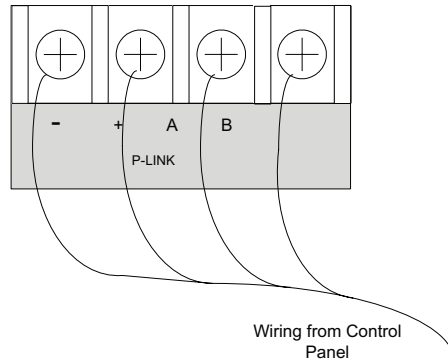

Figure 6

P-Link Repeater

The P-Link repeater output allows for system expansion by reconditioning and repeating all P-Link communications. The PSN-1000 repeater output provides an additional 1 amp at 24 VDC which can be used to power additional P-Link devices such as LCD Annunciators and/or SLC Loop expanders.

Wiring is fully supervised and power limited. Any connection to ground of 0 ohms will be annunciated as a ground fault.

P-Link Current = 1 Amp Each

P-Link Voltage = 24 VDC

Maximum wire length = 6,500 feet.

Maximum wire resistance = Maximum wiring resistance is based on load.

Calculate using the following equation

$$(\text{Total P-Link Alarm Current}) \times (\text{Wire Resistance}) < 6 \text{ volts.}$$

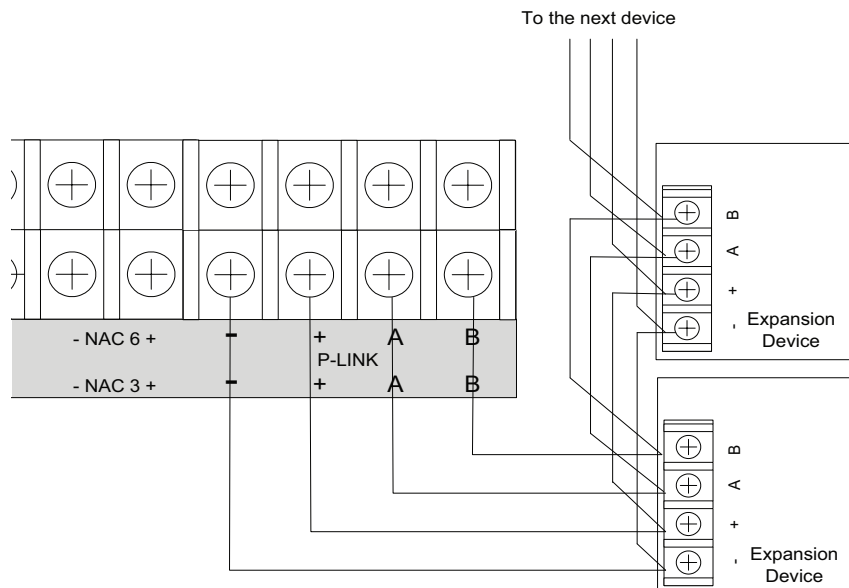

Figure 7 (P-Link Class B Wiring Example)

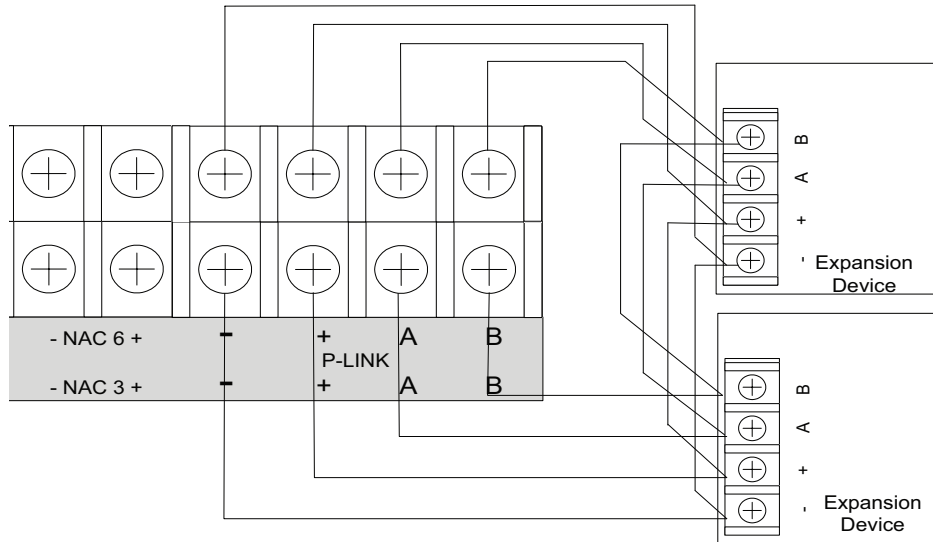

Figure 8 (P-Link Class A Wiring Example)

Releasing Device Circuit

The releasing circuit is fully supervised and power limited. The releasing device circuit is a NAC that is programmed to control a releasing device such as a solenoid or squib.

The output is a constant 24 VDC, regulated output. When connected to a releasing device, the circuit is a special application circuit and listed with the devices as outlined in Section 6 of this ULLD document.

The maximum current is 3 amps. The maximum line impedance is calculated using the following formula.

$$R_{\text{max}} (\text{ohm}) = (24\text{V} - V_{\text{min}} - 0.95\text{V}) / I_{\text{total}}$$

V_{min} is the lowest voltage operation of the connected devices.

I_{total} is the total current of the connected devices.

When a NAC is used as a releasing circuit, the End of Line Diode (EOLD) assembly must be installed. The EOLD is Potter part number 3005012 and 3002182 EOL Plate Assembly, and must be installed in accordance with the installation manual.

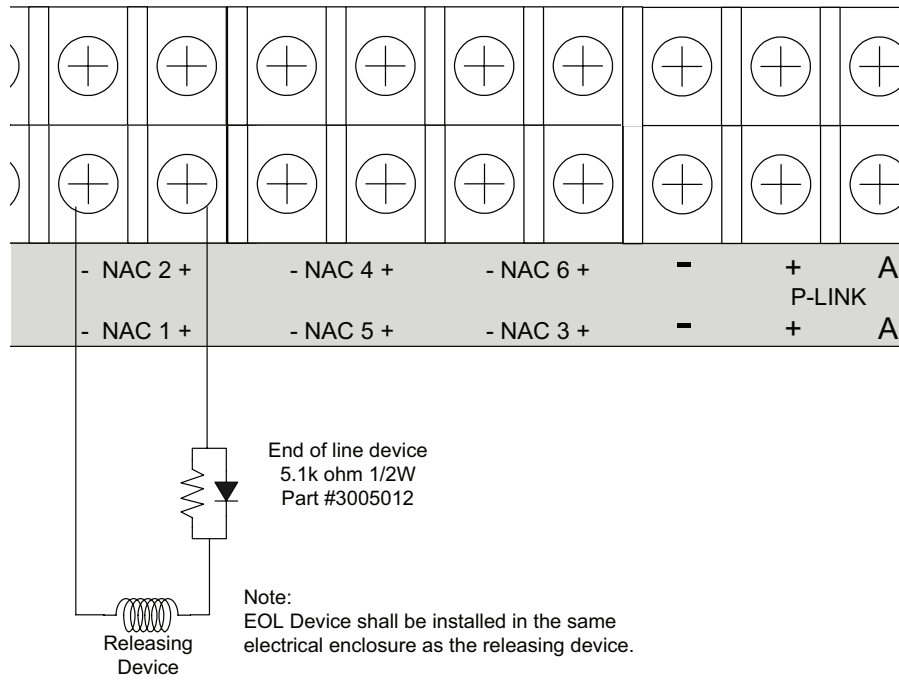

Figure 9

Municipal Box Connection

When programmed as a municipal box connection, the circuit is power limited, is supervised for open and short circuit conditions and provides a local energy connection.

Trip current = NAC1-NAC6 = 3 Amps

Max Voltage = 24 VDC

The panel has ground fault detection on municipal box connection circuits. The impedance to ground for ground fault detection is 0 ohms.

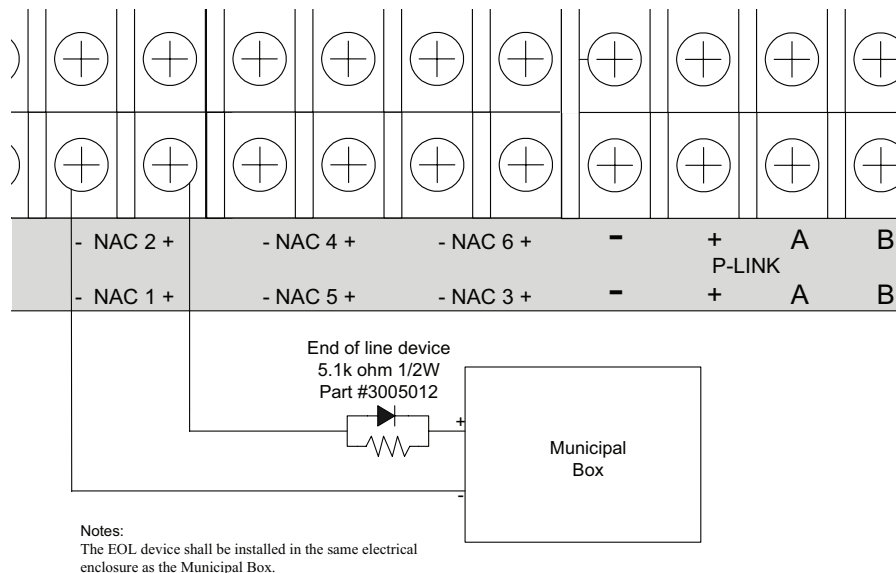

Figure 10

Relay Outputs

The panel has a dedicated trouble relay and low AC relay. The dedicated trouble relay is a failsafe trouble relay that changes position anytime a trouble condition occurs.

The contact rating is 24VDC / 3.0A, 125VAC / 3A, Power Factor: 1.0. These outputs are non-power limited and not supervised. However, they are power-limited if the power supply to the connected devices is power-limited.

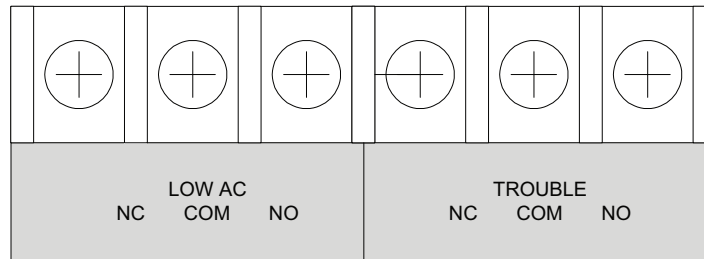

Figure 11

General Wiring Information

The cabinet has various conduit knockouts located around the cabinet for ease of wire installation. In addition, this method provides a means to separate different types of circuit to reduce electrical interference, transient voltage or voltage ratings.

The enclosure requires the use of power limited and non-power limited wiring on the main board as well as within the enclosure. Power limited wiring is to remain separated from non-power limited by a minimum of 0.25 inches and all cabling should be insulated to the higher voltage.

When the panel is installed, the National Electrical Code (NEC, NFPA 70) should be followed for the proper installation and separation of power limited and non-power limited circuits. The mixing of power limited and non-power limited should be avoided.

3. Functionality

The PSN-1000 & PSN-1000E provide power and communication expansion capability to the PFC-6000 series control panels. The PSN-1000 provides an electrically isolated Plink repeater output, providing additional power and communications distance. The larger cabinet of the PSN-1000E provides locations for mounting additional SLCE-127 SLC expanders.

The 6 NAC circuits are configured and controlled by the main control panel.

The PSN-1000 transfers from AC to battery instantly upon AC failure or brownout. The trouble relay will indicate the low AC condition after the Low AC Report Delay has elapsed.

LED behavior (Power Supply Board)

AC Power: ON = AC Present, OFF = AC not Present

Low Battery: OFF = No Fault. Flashing = Low battery Condition. ON = Battery Charger Failure

Earth Fault: Flashing = Earth Fault detected.

Comm: 1 second flash indicates normal communications with NAC control board

LED Behavior (NAC Control Board)

Bulk Comm: 1 second flash indicates normal communications with NAC control board

RPTR Comm: Flashes when P-Link repeater communications occur

Main Comm: Flashes when P-Link commands are received from the control panel

5 Position DIP Switch

A 5 position dip switch is provided for setting the ID of the PSN-1000/E. An ID in the range of 1-31 can be specified according to the table below.

PSN-1000/E ID	Dip Switch Settings				
	SW-1	SW-2	SW-3	SW-4	SW-5
1	On	Off	Off	Off	Off
2	Off	On	Off	Off	Off
3	On	On	Off	Off	Off
4	Off	Off	On	Off	Off
5	On	Off	On	Off	Off
6	Off	On	On	Off	Off
7	On	On	On	Off	Off
8	Off	Off	Off	On	Off
9	On	Off	Off	On	Off
10	Off	On	Off	On	Off
11	On	On	Off	On	Off
12	Off	Off	On	On	Off
13	On	Off	On	On	Off
14	Off	On	On	On	Off
15	On	On	On	On	Off
16	Off	Off	Off	Off	On
17	On	Off	Off	Off	On
18	Off	On	Off	Off	On
19	On	On	Off	Off	On
20	Off	Off	On	Off	On
21	On	Off	On	Off	On
22	Off	On	On	Off	On
23	On	On	On	Off	On
24	Off	Off	Off	On	On
25	On	Off	Off	On	On
26	Off	On	Off	On	On
27	On	On	Off	On	On
28	Off	Off	On	On	On
29	On	Off	On	On	On
30	Off	On	On	On	On
31	On	On	On	On	On

5. Testing/Maintenance

The power supply board has one fuse on the board for the AC power over current protection.

The AC fuse is rated at 8A 250VAC Time-Lag and screened onto the main board as F1.

The batteries are to be replaced at least once every four years. The batteries are required to be UL recognized batteries with a date of manufacture permanently marked on the battery. The battery is to be tested at least annually and if the battery is showing signs of failure, it is to be replaced.

The battery is to remain in the cabinet with nothing on or around the batteries. Only properly sized sealed lead acid batteries are to be used with the control panel. Use of another battery or not providing the proper clearance may result in a fire or an explosions.

The PSN-1000 is required to be installed in accordance with local and state building codes and NFPA 72 (National Fire Alarm Code).

The PSN-1000 and related system is required to be inspected and tested in accordance with NFPA 72.

6. Compatibilities

NAC Appliances

Please refer to Potter document 5403592-C NAC Compatibility Document

Releasing Circuit Devices (All 24 VDC Devices, only one device per circuit unless otherwise stated)

Nohmi - Koatsu R85M14, R85M10-N

Skinner – 73218BN4UNLVNOC111C2

Skinner – 73212BN4TNLVN0C322C2

Victaulic – 753-E Series

Viking – 11591, 11601, 11602, 13843 and 13844.

Fireaway - Stat-X Models 30E, 60E, 100E, 250E, 500E, 1000E, 1500E, and 2500E

Aero-K Models G30, G60, G100, G250, G500, G1000, G1500 and G2500

(Maximum of 10 per circuit)

Note: A Fireaway transient protection device (Part # 3005014) must be installed with each releasing device

Appendix A, Battery Calculation Work Sheets (Include for all P-Link devices being powered by the PSN-1000)

Description	Quantity	Standby (mA)	Total Standby (mA)	Alarm (mA)	Total Alarm (mA)
Main board (PSN-1000/1000E)	1	60	60	200	200
LCD Remote (RA-6075R or RA-6075)		20			
LCD Remote (RA-6500R or RA-6500)		20			
Other PSN-1000/E Power Expanders		15			
NAC 1					
NAC 2					
NAC 3					
NAC 4					
NAC 5					
NAC 6					
SLC Loop #__ (see SLC current draw worksheet)					
SLC Loop #__ (see SLC current draw worksheet)					
SLC Loop #__ (see SLC current draw worksheet)					
SLC Loop #__ (see SLC current draw worksheet)					
SLC Loop #__ (see SLC current draw worksheet)					
SLC Loop #__ (see SLC current draw worksheet)					
SLC Loop #__ (see SLC current draw worksheet)					
SLC Loop #__ (see SLC current draw worksheet)					
		Total (mA)		Total (mA)	
		Convert to Amps	x 0.001	Convert to Amps	x 0.001
		(*Refer to maximum allowable standby current) Total A		Total A	
				<u>60 Minutes per Hour</u>	
				Alarm time (minutes)	
		Multiply by standby hours	× _____		÷ _____
		Total Standby AH		Example:	
				5 minute alarm - Enter 12	
				10 minute alarm- Enter 6	
				Total Alarm AH	
				+Total Standby AH	
				Total AH	
				Efficiency Factor ÷0.80	
				Required AH	

*Maximum Allowable Standby Current		
	UL	ULC
7 AH	.230 A	N/A
18 AH	.619 A	.33 A
33 AH	1.151 A	.83 A
55 AH	1.930 A	1.56 A

Important Notes:

- 1) PSN-1000/E enclosure can house up to (2) 18 AH batteries. Larger batteries require accessory enclosure, Space Age Electronics part #SSU00500.
- 2) NFPA 72 - 2002 require 24 hours of standby power followed by 5 minutes alarm activation (30 minutes of alarm activation for ULC).
- 3) NFPA 12, 12A require 24 hours and five minutes of alarm activation.
- 4) Door holder circuits configured to disconnect upon AC loss need not be included in the battery standby calculation since they will not draw power during that time. Door holders will contribute to standby current draw when AC is present.
- 5) Total current must not exceed power supply rating (10 A)

SLC# ____ Current Draw Worksheet (Repeat for each SLCE-127 being powered by the PSN-1000)

Description	Qty	Standby (mA)	Total Standby (mA)	Alarm (mA)	Total Alarm (mA)
SLCE-127 Main Board	1	60	60	60	60
Analog photo smoke detector (PSA)		0.325		0.325	
Analog photo DUCT smoke detector (DSA)		0.325		0.325	
Analog photo smoke / fixed heat detector (PSHA)		0.325		0.325	
Analog fixed heat detector (FHA)		0.325		0.325	
Analog combo heat detector (RHA)		0.325		0.325	
Conventional initiating zone module - 4 inch mount (CIZM-4) *Note 1		0.325		1.0	
Miniature contact module (MCM)		0.325		0.325	
Single contact module - 4 inch mount (SCM-4)		0.325		1.0	
Dual contact module - 4 inch mount (DCM-4)		0.325		1.0	
Monitored output module - 4 inch mount (MOM-4) *Note 2		0.325		1.0	
Twin relay module - 4 inch mount (TRM-4)		0.325		1.0	
Short circuit isolator (SCI) *Note 3		0.325		2.34	
Analog sounder base (ASB)		0.325		0.325	
Analog relay base (ARB)		0.325		0.325	
Isolator base (AIB) *Note 3		0.325		2.34	
SLC alarm LED Current	n/a	n/a		n/a	27.0
		SLC Standby Current		SLC Alarm Current	

* Note 1: CIZM requires 24VDC power source. Standby current Style D = 4.90 ma, Style B (8.5 ma). Alarm Current = 50.0 ma

* Note 2: MOM requires 24VDC power source. Standby current = 1.6 ma. Alarm Current = 1.60 ma

* Note 3: In Class B (Style 4) installations the following rule must be observed:

- Number of SLC Devices
- + Number of Isolated branches * 8
- Must be <= 127

* Note 4: In Class A (Style 7) installations the following rule must be observed:

- Number of SLC Devices
- + Number of Isolators used
- Must be <= 127