

SL-5 SERIES CONICAL STROBE LIGHTS



- Designed to meet UL 1638 Visual Appliance Private Mode
- Polarized using filtered DC or unfiltered FWR input voltage
- 12 and 24V DC models
- Solid state circuitry and a xenon flash tube
- Impact resistant black abs base
- Interchangeable polycarbonate lens
- UL listed AWG#18 wire leads 10.6" long
- Optional surface mount plate model SP-SL1B
- Replacement interchangeable lens model SL-LG

The SL-5 series strobes are a high performance, high intensity, solid state strobe, designed for applications where 360° visual annunciation is required. The strobe light is UL 1638 approved and is listed for general utility signaling. The strobe is polarized for connecting to supervised circuits and is designed with a xenon flash tube. The SL-5 is a high profile strobe with a low current draw of 250mA at 24V DC. The strobe can be used as a stand alone or in combination with other signaling devices to provide a visual verification signal. The SL-5 series strobes are recommended for use in areas such as; parking facilities, schools, corridors, apartments, office buildings, restaurants, hotels, and any other application where effective visual warning is required. Installation must comply in accordance with applicable standards and/or all state and local electrical codes and authority having jurisdiction.

Strobe Structure

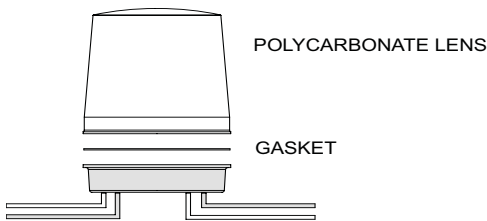

Wiring

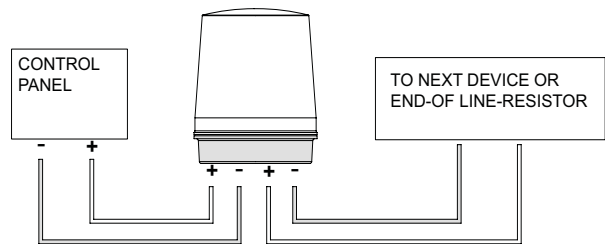

Model Number	Stock Number	Input Voltage	Strobe Lens Color	Average Current Amps	Rush Current Amps	Flash Rate (Flash/Min.)	Operating Temperature Range
SL-5 12A	4670021	12V DC	Amber	0.500	1.0	50-90	14°F - 122°F 0°C - 49°C
SL-5 12B	4670022	12V DC	Blue	0.500	1.0	50-90	
SL-5 12C	4670023	12V DC	Clear	0.500	1.0	50-90	
SL-5 12R	4670024	12V DC	Red	0.500	1.0	50-90	
SL-5 24A	4670009	24V DC	Amber	0.250	0.5	50-90	
SL-5 24B	4670010	24V DC	Blue	0.250	0.5	50-90	
SL-5 24C	4670011	24V DC	Clear	0.250	0.5	50-90	
SL-5 24R	4670012	24V DC	Red	0.250	0.5	50-90	

Engineering Specifications

The visual alarm indicating appliance shall be Amseco model SL-5 or equivalent device. The strobe shall be available in amber, blue, clear, and red lens and shall be listed in compliance with UL 1638 Visual Appliance Private Mode Emergency and General Utility for use in indoor applications. The signaling strobe shall operate from a non-coded regulated DC supply or full wave rectified, unfiltered supply. The signaling strobe shall be designed to produce a signal flash of 50-90 flashes per minute with continuously applied voltage. The strobe shall be capable of surface mounting to a 4" square box using Amseco's SP-SL1B plate. Visual signaling devices shall be installed as per plans and specifications.

Dimensions: inch (mm)

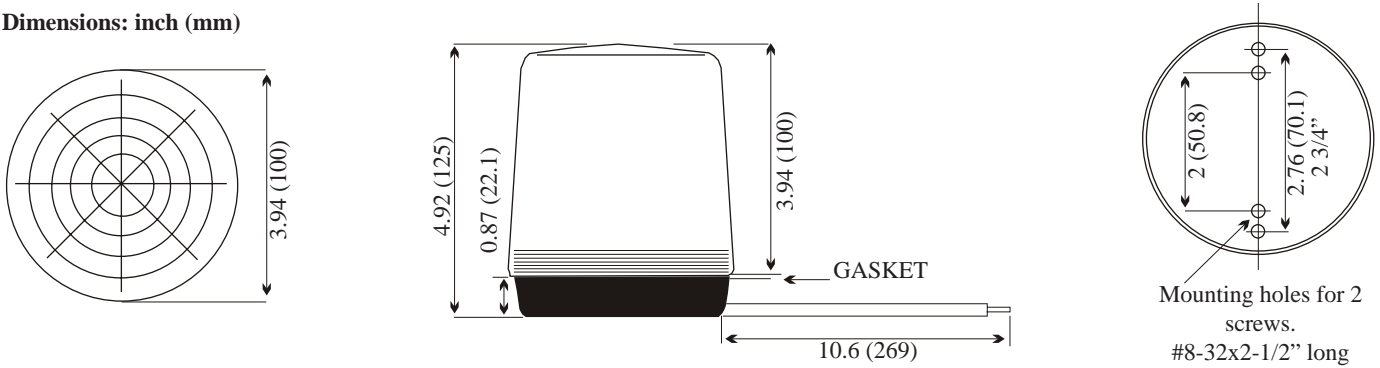

Surface Mounting

