

## AMS-10 SERIES MINI SURFACE MOUNT CONTACT



AMS-10C

AMS-T10C



AMS-10S

- UL and ULC Listed
- Slim design for tight spaces
- 3/4" operating gap
- Alnico 5 magnet
- Available in white, brown, gray, or ivory
- Screw or 3M adhesive

### Application

The AMS-10 Series Mini Surface Mount Contact is a UL Listed slim contact designed for tight spaces to accommodate hard to reach locations. The AMS-10 Series is available with side mount leads, center mount leads, or with terminals only. This provides options for fitting multiple applications. These devices can be used to protect openings such as: man doors, sliding doors, windows, or any other opening that requires a small contact.

### Dimensions

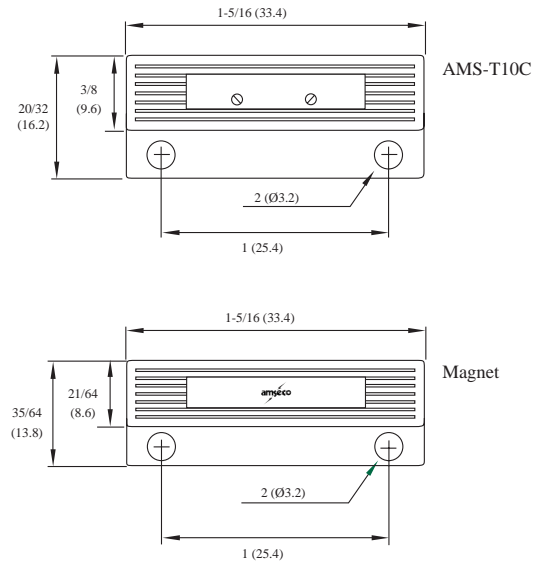

### Specifications

Model	Color	Stock Number	Contact	Contact Rating	Contact Type	Max. Carry Current	Max. Switching Current	Breakdown Voltage	Operating Gap	Mounting Method	Operating Temperature Range
AMS-10C	White	4350108	25" Center Lead	10VA	Form A N.O.	1.0 Amp	.3 Amp	200VDC min.	3/4"	Screw in or self-adhesive	32°F to 120°F (0°C to 49°C)
	Brown	4350098									
	Gray	4350100									
	Ivory	4350102									
AMS-10S	White	4350109	25" Side Lead								
	Brown	4350099									
	Gray	4350101									
	Ivory	4350104									
AMS-T10C	White	4350107	Terminal								
	Brown	4350106									