

Features

- Potter's IntelliGen™ Controller (Patent Pending)
 - Fully automates the air fill and nitrogen fill procedure
 - Advance leak rate detection
 - Integrated Bypass alarm
 - Web Enabled – system can be monitored anywhere there is internet connectivity
 - Automatically e-mails trouble alerts and maintenance reminders
- Two Integrated 0,37 kw (1/2 HP) oil-less air compressors included to meet NFPA 13 required 30 minutes fill for 1,987 liters (525 gallon) system at 2,76 bar (276 kPa) (40 psi).
- Handles up to 8,895 liters (2,350 gallons) of total sprinkler system capacity.
- Easy plug and play installation.
- 100 liters (26.4 gallon) nitrogen tank.
- Form C dry contacts for Building Management System (BMS) notification.



Description

Potter's IntelliGen™ Series of Nitrogen Generators are specifically designed to generate on-site, 98%+ purity nitrogen for use in fire protection sprinkler systems. When used as a supervisory gas in fire sprinkler systems, nitrogen slows corrosion, improves the life of your system, and lowers maintenance costs.

The INS-600 (AP) utilizes nitrogen membrane technology for gas separation. Nitrogen membranes are highly effective and a cost conscious way of producing on-site nitrogen. Acting as a gas filter, the nitrogen membrane separates the oxygen and water vapor molecules in the air from the nitrogen molecules. The high purity nitrogen gas is then piped through the air maintenance device and into the fire protection system. As the system fills with nitrogen, the remaining oxygen molecules in the fire protection system are exhausted by using the Potter IntelliPurge® Nitrogen Purge Valve. The Potter IntelliPurge® Nitrogen Purge Valve monitors the fire protection system to ensure high purity nitrogen is consistent throughout the sprinkler system.

The INS-600 (AP) is a fully assembled package ready to be connected to a new or existing fire sprinkler system. This turn-key system includes an integrated air compressor, nitrogen membrane, tank, all air filtration equipment, and the Potter IntelliGen™ Controller.

The Potter IntelliGen™ Controller ensures the contractor the easiest setup and operation of any nitrogen generator system in the industry. Each unit is designed to be turned on and walk away. The built-in monitoring capabilities will make corrections and alert you to any necessary changes.

Technical Specifications

Nitrogen Cabinet Size	1173mm (46 1/4")H X 651mm (25 5/8")W X 488mm (19 1/4")D
Nitrogen Tank Size	687mm (27")H X 944mm (37 1/8")W X Ø 400mm (15 3/4")D
Weight	93 kg (205 lbs.)
Power Supply Available in:	220-240V (5.4A) single phase 50 Hz
Fire Sprinkler System Connection	½" Female BSPT
Nitrogen Cabinet Mounting Bracket Holes	(4) Ø 7,9mm (Ø 5/16")
Nitrogen Tank Mounting Holes	(4) Ø 9,5mm (Ø 3/8")
Operating Pressure	8,27 bar (827 kPa) (120 psi)
Temperature Range	10°C (50°F) to 43°C (110°F)

Installation

The Potter INS-600 (AP) should be installed in a dry, clean, and well ventilated room with ambient temperatures above 10°C (50°F) at all times. Allow access to the front for service and place the unit in a location that is conveniently located near fire sprinkler system connections, a drain, and a dedicated electrical connection. The Potter IntelliGen™ Nitrogen Generator should always be installed in an adequately ventilated room. Rapid release of nitrogen gas into an enclosed space displaces the oxygen and can cause an asphyxiation hazard. For detailed installation and operation instructions please refer to the Potter IntelliGen™ Nitrogen Generator Manual #5403820.

Cabinet Dimensions

Fig 1

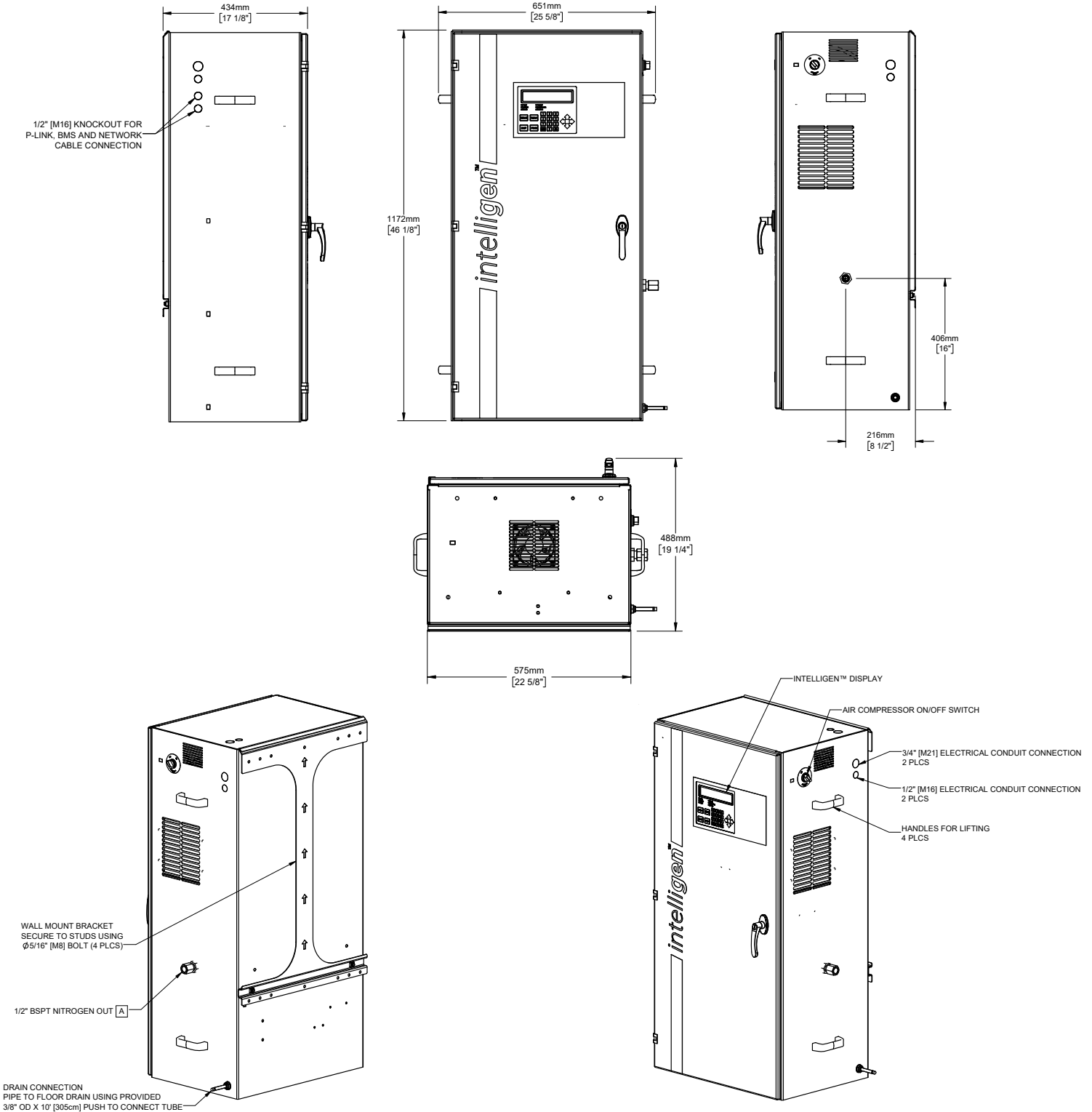

Tank Dimensions

Fig 2

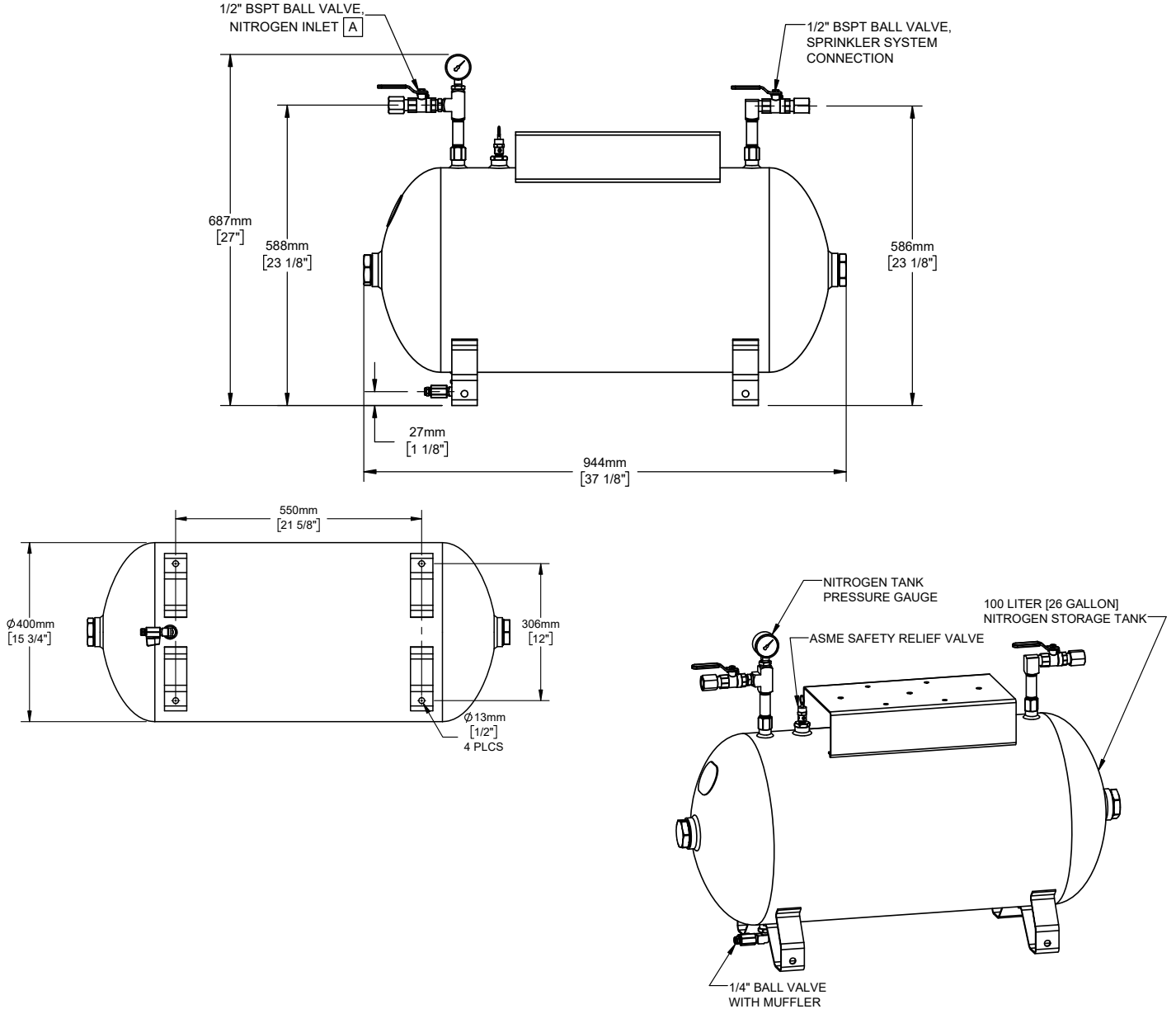

Ordering Information

Part Number	Model	Description
1119854	INS-600 (AP), 220-240VAC 1PH 50HZ	IntelliGen™ Nitrogen System-600 (AP), 220-240VAC Single Phase 50HZ
1119478	INS-PV	IntelliPurge® Nitrogen Purge Valve
1119784	NGP-SPV	Potter Purge Valve
1119660	AAMD	Advanced Air Maintenance Device
1119504	PNA	Portable Nitrogen Analyzer