

**Features**

- Single module with two (2) channel audio inputs
- One (1) Class B or Class A audio output channel
- SLC Class A, Class X & Class B
- Mounts in a standard 4” or double gang box
- Wiring terminals accessible when mounted in box
- All wiring terminals accept 22 to 12 AWG
- Switches maximum 60 watts
- Product includes a 5 year warranty
- UUKL Listed for Smoke Control



**Description**

The PAD100-SM uses one (1) SLC loop address. The module mounts on either a 4” square or double gang box. The module is capable of switching one of the two audio input channels to its audio output channel. The PAD100-SM includes one red LED to indicate the module’s status. In normal condition, the LED flashes when the device is being polled by the control panel.

**Application**

The PAD100-SM is compatible with Potter’s IPA and AFC/ARC series addressable fire alarm control panels. The PAD100-SM is an audio switch module to be used in audio switching applications.

**Setting the Address**

Each addressable SLC device must be assigned an address. The address is set using the DIP switch located on the PAD100-SM. Each input channel is identified as a sub-point of the module address. For example, if the address number is assigned as “8”, the first input channel will be “8.1” and the second input channel will be “8.2”.

Before connecting a device to the SLC loop, take the following precautions to prevent potential damage to the panel or device:

1. Power to the device is removed.
2. Field wiring is correctly installed.
3. Field wiring has no open or short circuits.

**Technical Specifications**

Operating Voltage	24.0V
Max SLC Standby Current	240µA
Max SLC Alarm Current	240µA
Max Output Rating	2A @30VDC, 0.5A @125VAC, 60 WATTS
EOL Resistor	5.1K Ω
Operating Temperature Range	32 to 120°F (0 to 49°C)
Operating Humidity Range	0 to 93% (non-condensing)
Max no. of Module Per Loop	127 units
Dimensions	4.17” (106mm)L × 4.17” (106mm)W × 1.14” (29mm)D
Mounting Options	Standard 4” Square or Double Gang Box
Shipping Weight	0.6 lbs

**Installation Using Compatible Electrical Box**

Fig 1

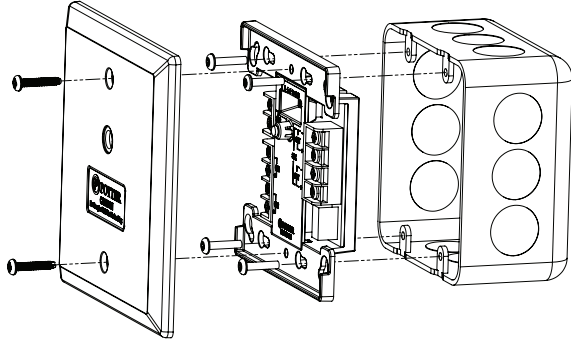

**Wiring Diagrams**

*PAD100-SM With One Class B Output Channel*

Fig 2

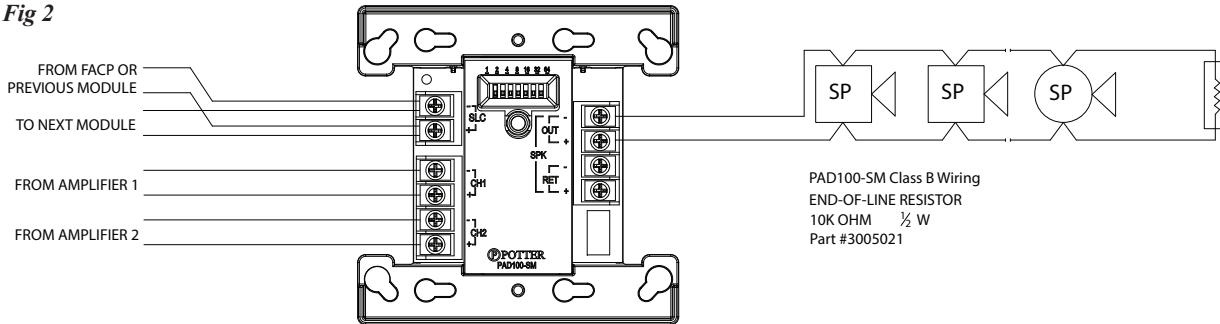

*PAD100-SM With One Class A Output Channel*

Fig 3

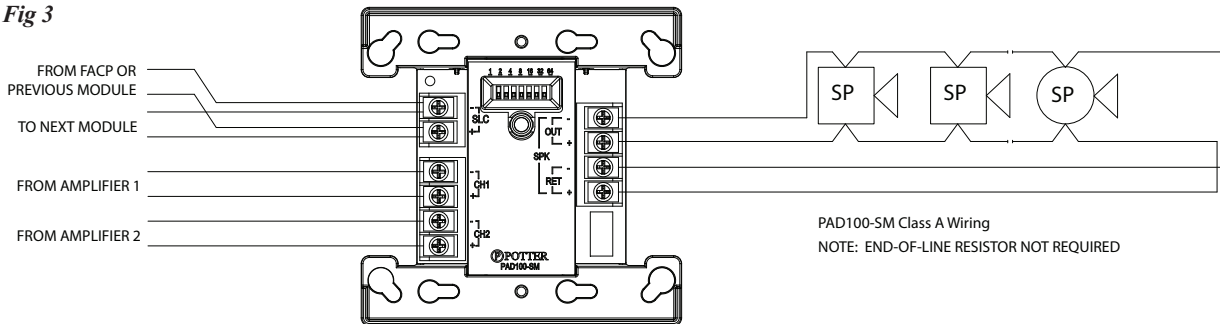

**NOTICE**

It is possible that the internal relay in the PAD100-SM may be shipped in the non-normal / activated state. To ensure that the internal relay is set to the normal state, connect the module to the SLC loop and reset the control panel before terminating the wiring to the modules output.

**Ordering Information**

Model	Description	Stock No.
PAD100-SM	Speaker Module	3992724