



**Model SPB-24N**

**Stock #1430027**

**STANDARD FEATURES**

- Microprocessor based for reliability
- Simple setup & alignment with signal strength LED's
- Provides 60 feet on center linear protection at a range of 32.8 feet to 328 feet
- Automatic compensation for signal drift or dirty lens
- Three field adjustable sensitivity settings
- Form A alarm and Form B trouble contacts
- Calibrated filters available to verify sensitivity
- Color-coded emitter and receiver labels for easy recognition

**SPECIFICATIONS**

Rated Voltage	24VDC
Working Voltage	19VDC - 33VDC
Supervisory Current	250uA @ 24VDC
Alarm Current	20mA @ 24VDC
Trouble Current	20mA @ 24VDC
Ambient Temperature	
Range	32°F-122°F
Sensitivity Test Feature	Manufacturers test filters
Dimensions	5.5" Tall 3.2" Wide 4.0" Deep
Mounting	Wall mount or Single Gang Box

*Specifications subject to change without notice.*

**APPLICATION**

The SPB-24N Projected Beam Smoke Detector consists of an emitter and receiver. The projected beam smoke detector should be placed so that smoke generated by a fire will likely rise into the path of the beam. The receiver is constantly monitoring and measuring the intensity of the beam transmitted by the emitter. Should the smoke from a fire cause a decrease in the signal strength of a magnitude that exceeds the programmed obscuration setting, an alarm signal is generated.

The SPB-24N Projected Beam Smoke Detector can provide vital fire detection in applications where other type detectors may not be able to respond quickly, or at all, to a fire condition. Examples of some applications where projected beam smoke detectors have been successfully used include:

*atriums, gymnasiums, theatres, museums,  
factories, tunnels, churches, stables,  
anechoic chambers*

and high air velocity areas. The SPB- 24N Projected Beam Smoke Detector may also be used in conjunction with more traditional spot type smoke detection devices to provide an even more comprehensive detection system.

*For more information on how to install the SPB-24N Projected Beam Smoke Detector consult the SPB-24N Installation Instruction Guide and the applicable NFPA Standards for additional guidance.*

**OPERATION**

The near infrared pulsed beam generated by the emitter is sensed by the photodiode of the receiver, where it is converted into an electrical signal. This signal is then amplified and applied, via an analog to digital converter, to a microprocessor. The normal state signal (the initial beam data) once stored in the microprocessor is used as reference for comparison with subsequent beam signals.

When there is a difference between actual beam strength and stored reference data that exceeds the programmed alarm

**OPERATION, continued**

obscuration reference level, a fire signal is produced. A trouble signal is generated if the beam is more than 90% obstructed (as opposed to partially obscured by smoke).

The microprocessor also provides compensation for a change in received signal value, with time, caused by contamination of the optics. Since such a change with time appears as a slow change in the beam signal, the microcomputer compensates in such a manner that the signal moves closer to the reference data at a rate approximately +1% per hour. When this compensating capability reaches a limit, the microcomputer automatically generates a trouble signal.

A calibrated test filter is available upon request to test and verify the sensitivity setting of the projected beam smoke detectors.

**ENGINEERING SPECIFICATIONS**

The contractor shall furnish and install, where indicated on the plans, the SPB-24N Projected Beam Smoke Detector. The detector shall have a range of 32.8 feet to 328 feet. The projected beam smoke detector shall be field adjustable to one of the three obscuration settings of 25%, 50% or 70% per span. These settings shall be capable of being verified with calibrated filters. Side to side spacing shall be a maximum of 60 feet on center.

The projected beam smoke detector shall possess circuitry that automatically compensates for normal ambient changes in the intensity of the emitted beam strength. The microprocessor shall provide compensation for a change in received signal value, with time, caused by contamination of the optics. Since such a change with time appears as a slow change in the beam signal, the microcomputer compensates in such a manner that the signal moves closer to the reference data at a rate of approximately +1 % per hour. When this compensating capability reaches a limit, the microcomputer automatically generates a trouble signal.

The projected beam smoke detector(s) shall also signal a trouble condition if the beam has a blockage of 90% or more than 20 seconds and automatically resets to normal when blockage is removed.

The projected beam smoke detector(s) shall be UL listed for these applications. Voltage and RF transient protection shall be integral to the internal circuitry of the projected beam smoke detector so as to minimize false alarm potential.

To facilitate easy installation and setup, the projected beam smoke detectors shall employ signal strength indicating LEDs. Alignment shall be facilitated by turning an alignment adjustment wheel and monitoring the relative signal strength based upon which LEDs are illuminated.

The detectors shall also illuminate a red LED, which is visible externally, when an alarm condition is indicated.

The projected beam smoke detector shall provide a Form "A" dry contact for alarm and Form "B" dry contact for trouble.

**INSTALLATION**

The SPB-24N Projected Beam Smoke Detector shall be installed in accordance with the *Installation Instruction Guide* provided with every unit. Refer to the applicable NFPA Standards for additional guidance on spacing, irregular ceiling surfaces and other design considerations.

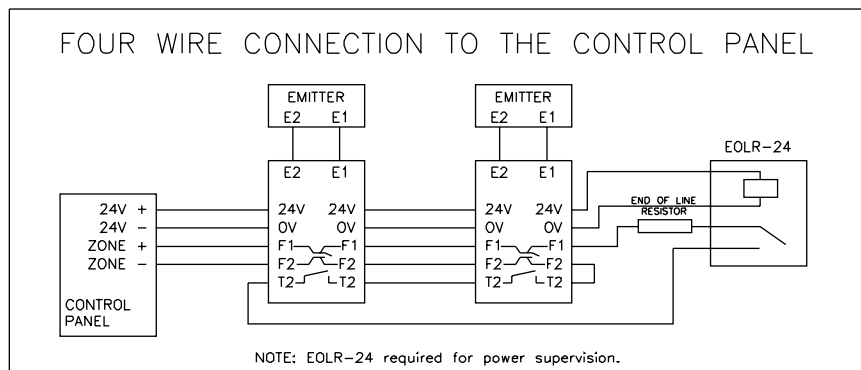

DWG #8840016-1