

EBP-401 LONG RANGE DOOR ANNUNCIATOR SYSTEM



- Intelligent microprocessor driven system
- 40 ft. detection range across doorway
- Four user selectable chime sounds
- Advanced circuit integrated with active-infrared beam technology
- High/low volume control
- Expandable using additional chimes (CM-5)

Stock number: 4130030

The EBP-401 is a surface mount, 40 ft., long range annunciator system using active infrared technology. This invisible single infrared beam triggers a pleasant chime sound when the infrared beam is interrupted. The system can be installed anywhere inside the buildings where traffic surveillance is required.

Complete Kit Includes:

- 1 Electronic chime
- 1 Infrared sensor
- 1 Reflector
- 1 Power transformer (12V AV 20VA)
- 1 Long plastic bracket
- 1 Metal short bracket
- 1 Short plastic bracket
- 1 6 ft. power cord with in-line switch
- 1 26 ft. 2-conductor wires
- 6 3/4" sheet metal screws
- 1 3/8" bolt w/locking washer
- 2 5/8" machine screws w/washers and nuts
- 1 Manual

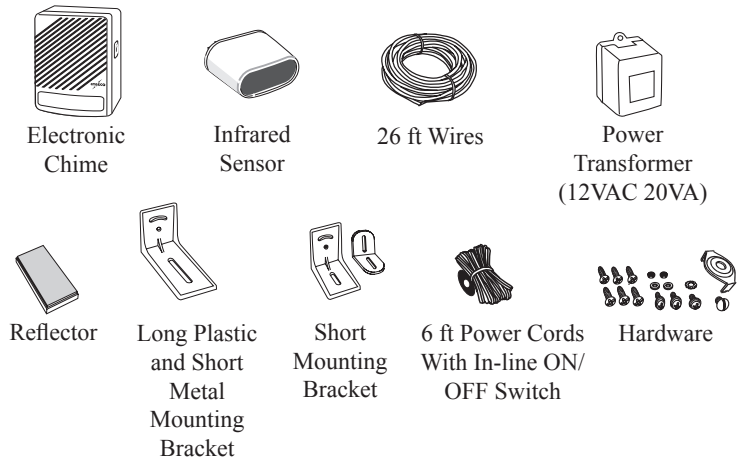

Wiring Diagram

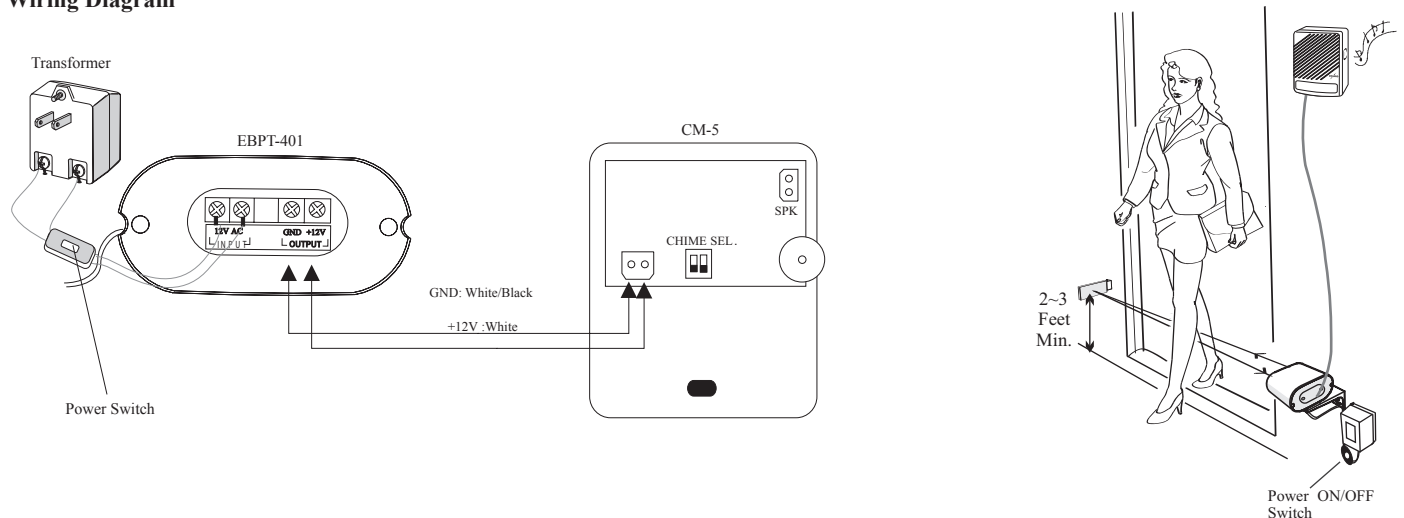

EBP-401

LONG RANGE DOOR ANNUNCIATOR SYSTEM

Installation

NOTICE

If necessary, use cable ties to keep wires safely out of the way to avoid tripping.

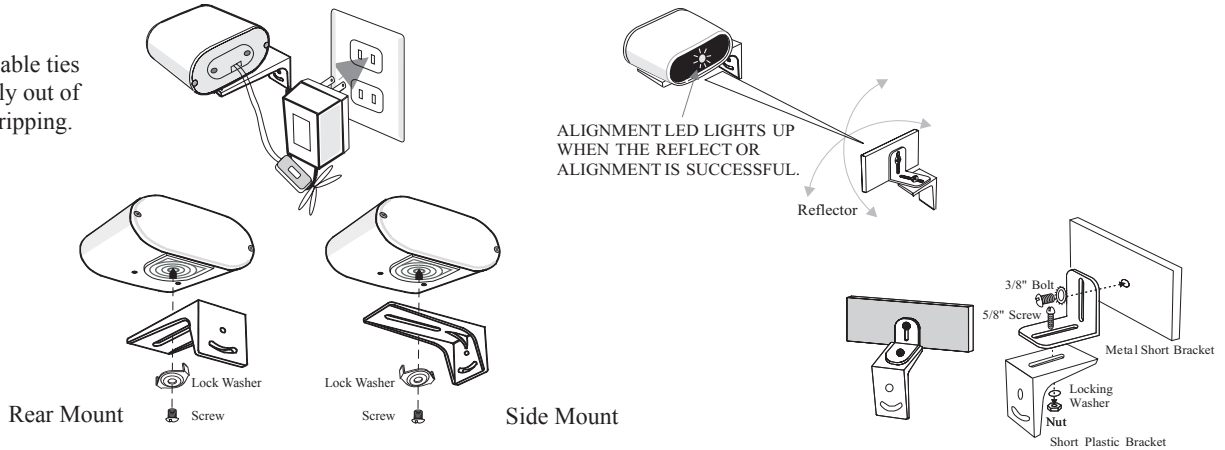

Specifications

Part Information	EBP-401
Description	Long Range Wired Annunciator System
Detection method	Active infrared
Detection range	40 ft.
Maximum transmission range	1000 ft. AWG#22 2P wire
Power source	Sensor: 12V AC/DC, 20VA Chime: 12V DC, 10VA
Power consumption: Standby	Sensor: 50mA Chime: 100mA
Power consumption: In alarm	Sensor: - Chime: 500mA
Volume level	80dB (low) - 95dB (high)
Chime sounds selection	Selectable among 4 sounds by a dip SW
Chime sounds level selection	JP1 (Jumper SHORT LOW Jumper OPEN HIGH)
Response time	4m sec.
Light source	Infrared pulse beam 950mm
Installation location	Indoor
Infrared beam interception warning	Sensor: JP1 selectable OFF/10 sec/60 secretary
Install setting	Transformer Power ON - Red Alignment LED ON - Transformer Power OFF - Transformer Power ON - Setting
Power switch	Yes
Temperature	14°F - 122°F (-10°C - 50°C)
Weight	Sensor: 125g Chime: 164.4g
Dimension: (W x H x D)	Sensor: 2 1/2" x 1 7/8" x 3 7/16" Chime: 4 7/8" x 3 1/2" x 1 3/8"