



1609 Park 370 Pl, Hazelwood, MO 63042
www.pottersignal.com



PAD300-CD

PAD300-PCD

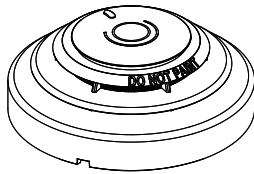
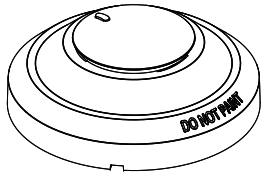

Contents

- | | |
|--------------------|---------------|
| A. Introduction | E. Addressing |
| B. Specifications | F. Testing |
| C. Installation | G. Cleaning |
| D. Locking Feature | H. Warranty |

A. Introduction

The PAD300-CD is an intelligent addressable CO (Carbon Monoxide) detector and PAD300-PCD is an intelligent addressable detector with a photoelectric smoke sensor and a CO sensor. The photo and CO sensors on the PAD300-PCD work independently and generate a separate signal to the panel. The CO sensor utilized in both models has a 10-year lifespan.

Each detector includes one (1) LED to indicate the device status. The LED flashes momentarily in normal conditions and flashes at a fast rate when activated. The LED can be turned off using the programming software.

The PAD300-PCD has a maximum spacing limitation of 30ft. Place the detector as close to the center of the ceiling as possible. It may be wall mounted within 12 inches from the ceiling. To minimize false alarms, avoid placing in areas where excessive dust, humidity, air movement, or extreme temperature is present. Refer to NFPA 72 for more details regarding spacing, placement and special applications.

The PAD300-CD and PAD300-PCD communicate on a proprietary protocol to the addressable fire alarm control panel. Each detector must be connected to either the IPA series, AFC series, or ARC fire alarm control panel for proper operation. For detector sensitivity settings and supervision, please refer to the panel installation instructions.

Refer to the company website for the latest revision of this manual.

B. Specifications

PAD300-CD	
Operating Voltage	24 VDC
Standby Current (*)	300 μ A
Alarm Indicator Current	1.4 mA
CO Alarm Rating	70 ppm, 150 ppm, 400 ppm
Installation Temp Range	32°F to 100°F
Operating Humidity Range	0% - 93% (Non-condensing)
Dimension	Φ 3.93 in
Weight	2.68 oz
Height	1.22 in

*Standby current is the current the device consumes when the device is in a non-activated condition and where no communication current is transmitted to the fire alarm control panel.

PAD300-PCD	
Operating Voltage	24 VDC
Standby Current (*)	300 μ A
Alarm Indicator Current	1.4 mA
CO Alarm Rating	70 ppm, 150 ppm, 400 ppm
Smoke Sensitivity	1.1 to 3.5%/ft
Installation Temp Range	32°F to 100°F
Operating Humidity Range	0% - 93% (Non-condensing)
Dimension	Φ 3.93 in
Weight	3.25 oz
Height	1.42 in

C. Installation

Installation must meet the requirements of the Authority Having Jurisdiction (AHJ). It is recommended to follow guidelines as described in NFPA 72.

- Before connecting a device to the SLC loop, take the following precautions to prevent potential damage to the SLC or device.
 - Use only the PAD300 series bases PAD300-4DB, PAD300-6DB, PAD300-SB, PAD300-LFSB, PAD300-RB, and PAD300-IB (supplied separately).
 - Confirm the field wiring to device is correctly installed on the base. Refer to the base manual.
 - Enable the locking feature if needed. Refer to section D for details of the locking feature.
- Set the desired address using the DIP switch located on back of the sensor. See section E for addressing instructions.
- Plug detector into base and turn clockwise to secure in place.

CAUTION KEEP DUST COVER ON DETECTOR DURING CONSTRUCTION. REMOVE DUST COVER TO ALLOW THE DETECTOR TO DETECT SMOKE AND CO. DETECTORS ARE NOT TO BE USED WITH DETECTOR GUARDS UNLESS THE COMBINATION HAS BEEN EVALUATED AND FOUND SUITABLE FOR THAT PURPOSE.

D. Locking Feature

The device includes a tamperproof feature that locks the detector and does not allow removal without the use of a tool.

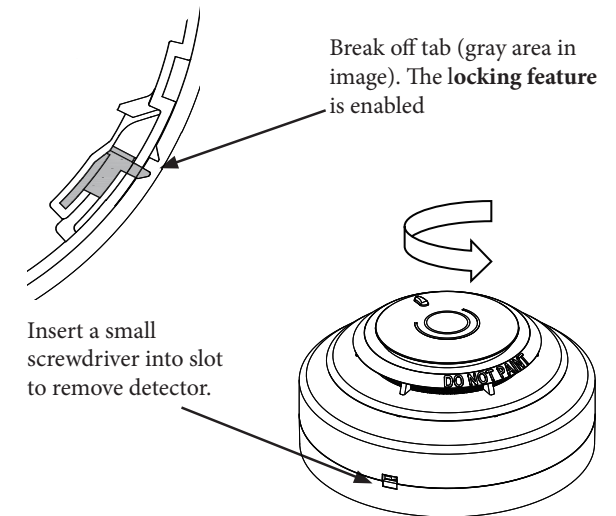

E. Addressing

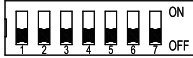

Detector address can be configured using the table below for DIP switch position settings.

POS	DIP Switch on	POS	DIP Switch on	POS	DIP Switch on
1	1	43	1,2,4,6	85	1,3,5,7
2	2	44	3,4,6	86	2,3,5,7
3	1,2	45	1,3,4,6	87	1,2,3,5,7
4	3	46	2,3,4,6	88	4,5,7
5	1,3	47	1,2,3,4,6	89	1,4,5,7
6	2,3	48	5,6	90	2,4,5,7
7	1,2,3	49	1,5,6	91	1,2,4,5,7
8	4	50	2,5,6	92	3,4,5,7
9	1,4	51	1,2,5,6	93	1,3,4,5,7
10	2,4	52	3,5,6	94	2,3,4,5,7
11	1,2,4	53	1,3,5,6	95	1,2,3,4,5,7
12	3,4	54	2,3,5,6	96	6,7
13	1,3,4	55	1,2,3,5,6	97	1,6,7
14	2,3,4	56	4,5,6	98	2,6,7
15	1,2,3,4	57	1,4,5,6	99	1,2,6,7
16	5	58	2,4,5,6	100	3,6,7
17	1,5	59	1,2,4,5,6	101	1,3,6,7
18	2,5	60	3,4,5,6	102	2,3,6,7
19	1,2,5	61	1,3,4,5,6	103	1,2,3,6,7
20	3,5	62	2,3,4,5,6	104	4,6,7
21	1,3,5	63	1,2,3,4,5,6	105	1,4,6,7
22	2,3,5	64	7	106	2,4,6,7
23	1,2,3,5	65	1,7	107	1,2,4,6,7
24	4,5	66	2,7	108	3,4,6,7
25	1,4,5	67	1,2,7	109	1,3,4,6,7
26	2,4,5	68	3,7	110	2,3,4,6,7
27	1,2,4,5	69	1,3,7	111	1,2,3,4,6,7
28	3,4,5	70	2,3,7	112	5,6,7
29	1,3,4,5	71	1,2,3,7	113	1,5,6,7
30	2,3,4,5	72	4,7	114	2,5,6,7
31	1,2,3,4,5	73	1,4,7	115	1,2,5,6,7
32	6	74	2,4,7	116	3,5,6,7
33	1,6	75	1,2,4,7	117	1,3,5,6,7
34	2,6	76	3,4,7	118	2,3,5,6,7
35	1,2,6	77	1,3,4,7	119	1,2,3,5,6,7
36	3,6	78	2,3,4,7	120	4,5,6,7
37	1,3,6	79	1,2,3,4,7	121	1,4,5,6,7
38	2,3,6	80	5,7	122	2,4,5,6,7
39	1,2,3,6	81	1,5,7	123	1,2,4,5,6,7
40	4,6	82	2,5,7	124	3,4,5,6,7
41	1,4,6	83	1,2,5,7	125	1,3,4,5,6,7
42	2,4,6	84	3,5,7	126	2,3,4,5,6,7
				127	1,2,3,4,5,6,7

F. Testing

Testing must meet the requirements of the Authority Having Jurisdiction (AHJ). It is recommended to follow guidelines as described in NFPA 72.

It is important to test the product after installation and periodically to ensure it functions properly.

CAUTION NOTIFY APPROPRIATE AUTHORITY BEFORE TESTING THE DETECTOR. PLACE FIRE PANEL IN *WALK TEST* MODE BEFORE CONDUCTING THE FOLLOWING TEST. REFER TO THE PANEL INSTALLATION MANUAL FOR DETAIL.

CO Aerosol Test

Use Solo C6 CO Aerosol with SDI Solo 330 Dispenser to verify the CO sensor. Please contact local fire and safety equipment distributors for the specified product. Units failing the aerosol test should be immediately serviced or replaced.

Smoke Aerosol Test

Use a canned aerosol to spray directly to the side of the detector. SmokeCheck 25S from HSI Fire and Smoke Centurion from SDi are acceptable. Please contact local fire and safety equipment distributors to see which products are available. Units failing the aerosol test should be immediately cleaned. If cleaning cannot restore the unit to normal, it should be replaced.

Magnet Test

The magnet test provides a quick test to verify the connections and the detector electronically. This test should not replace the aerosol test, which is required as part of regular test and maintenance per NFPA 72.

1. Hold the test magnet in the magnet test area as shown below.

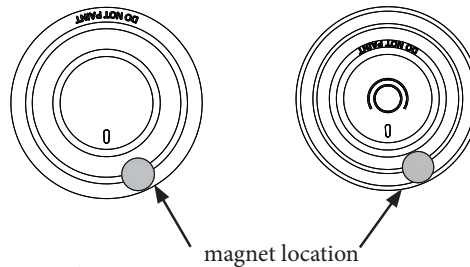

2. The LED flashes rapidly to indicate the detector is in alarm.
3. Remove magnet.
4. Alarm on the fire alarm panel should be reset.
5. If the unit fails the magnet test, test the unit with an aerosol testing spray to confirm any failures.

G. Cleaning

NOTE: Before cleaning, notify the proper authorities that the system is undergoing maintenance. Disable the loop or system undergoing maintenance to prevent unwanted alarms. It is recommended that the smoke detector be removed from its mounting base for easier cleaning and that the detector be cleaned at least once a year. Use a vacuum cleaner to remove dust from the sensing chamber.

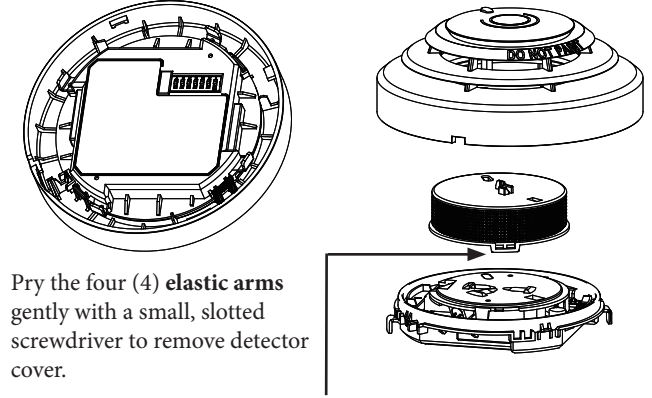

Pry the four (4) **elastic arms** gently with a small, slotted screwdriver to remove detector cover.

Pry the **elastic arm** gently with a small, slotted screwdriver to remove cage for cleaning.

H. Warranty

POTTER warrants that the equipment herein shall conform to said descriptions as to all affirmation of fact and shall be free from defects of manufacture, labeling, and packaging for a period of five (5) years from the invoice date to the original purchaser, provided that representative samples are returned to POTTER for inspection. The product warranty period is stated on the exterior of the product package. Upon a determination by POTTER that a product is not as warranted, POTTER shall, at its exclusive option, replace or repair said defective product or parts thereof at its own expense, except that Purchaser shall pay all shipping, insurance, and similar charges incurred in connection with the replacement of the defective product or parts thereof. This Warranty is void in the case of abuse, misuse, abnormal usage, faulty installation, or repair by unauthorized persons, or if for any other reason POTTER determines that said product is not operating properly as a result of causes other than defective manufacture, labeling, or packaging.