

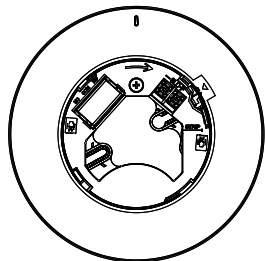

1609 Park 370 Pl, Hazelwood, MO 63042
www.pottersignal.com



PAD300-RB



Contents

- | | |
|-------------------|--------------------|
| A. Introduction | D. Wiring |
| B. Specifications | E. Locking Feature |
| C. Mounting | F. Warranty |

A. Introduction

The PAD300-RB is an addressable relay base. It is compatible with Potter's addressable fire alarm control panels.

The PAD300-RB is a mounting base designed to work specially with the PAD300 series detectors. Compatible detectors include PAD300-PD, PAD300-HD, PAD300-PHD, PAD300-CD and PAD300-PCD.

The PAD300-RB does not consume extra address on the loop but is assigned a sub-address from the attached detector. It does not require an auxiliary power source.

Each base includes one (1) LED which flashes momentarily in normal and detector alarm conditions. The LED can be turned off using the programming software.

For further information, please refer to the control panel installation instructions.

Refer to the company website for the latest revision of this manual.

B. Specifications

Specifications / Ratings for detector base only:

	PAD300-RB
SLC Voltage	24 VDC
SLC Standby / Alarm Current (*)	200 μ A
Relay Rating	2A @ 30 VDC 0.5A @ 125 VAC
Installation Temp Range	32°F to 150°F
Operating Humidity Range	0% - 93% (Non-condensing)
Dimension	Φ 6.4 in
Weight	7.05 oz
Height	1.57 in

*Standby current is the current the device consumes when the device is in a non-activated condition and where no communication current is transmitted to the fire alarm control panel.

C. Mounting

Mounting Options:

PAD300-RB can be mounted on a single gang, 3-1/2" octagon, 3-1/2" square, double gang, 4" octagon, 4" square, 50mm c/c, 60mm c/c and 70mm c/c boxes.

Terminal Layout:

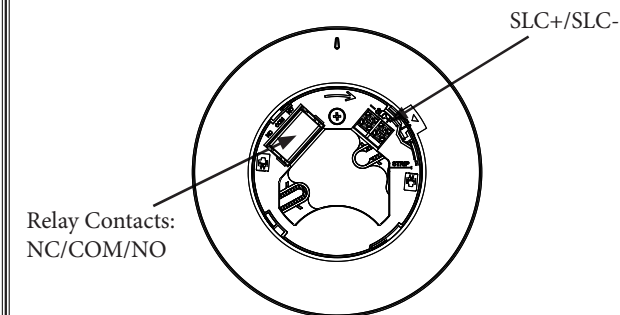

Mounting Instructions:

- Loosen screws on junction box or leave screws in place.
- Align keyholes on the mounting plate with screw heads.
- Slide screws to the slot on the mounting plate.
- Tighten screws to secure mounting plate.
- Plug base and turn clockwise to secure in place. Tighten screws to secure base on mounting plate.

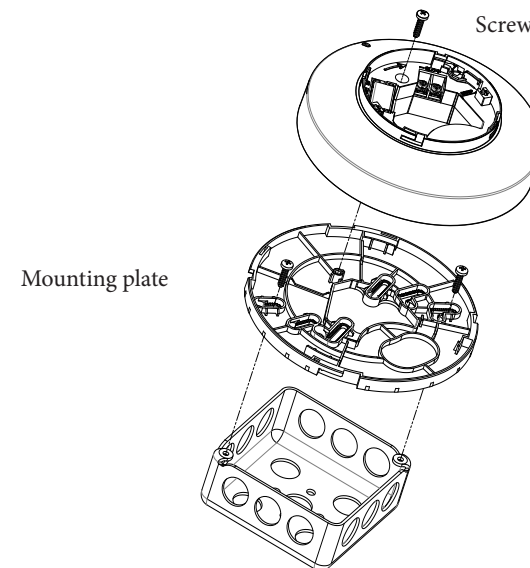

CAUTION DETECTORS ARE NOT TO BE USED WITH DETECTOR GUARDS UNLESS THE COMBINATION HAS BEEN EVALUATED AND FOUND SUITABLE FOR THAT PURPOSE.

D. Wiring

All terminals are power limited and should be wired in accordance with the requirements of NFPA 70 (NEC) and NFPA 72 (National Fire Alarm Code). Failure to follow the wiring diagrams in the following pages will cause the system to not operate as intended.

- Before connecting a device to the SLC loop, take the following precautions to prevent potential damage to the SLC or device.
 - Power to the SLC is removed.
 - Field wiring on device is correctly installed on the base (supplied separately). Beware of the polarity marked next to the terminals. S+ is positive and S- is negative.
 - Use wires between size 22 AWG to 12 AWG.
 - Strip all wires 1/4 inch from their edges shown here:



- Field wiring has no open or short circuit.
- Set the desired address using the DIP switch located on back of the sensor. Refer to addressing instruction in the manual of detector.
- Plug sensor on base and turn clockwise to secure in place. Refer to section E for detail of the locking feature.

CAUTION DO NOT LOOP WIRE AROUND TERMINAL. SEPARATE WIRES TO ALLOW FOR CONNECTION SUPERVISION.

The product may be installed as a Class B, Class A or Class X.

Class B Wiring:

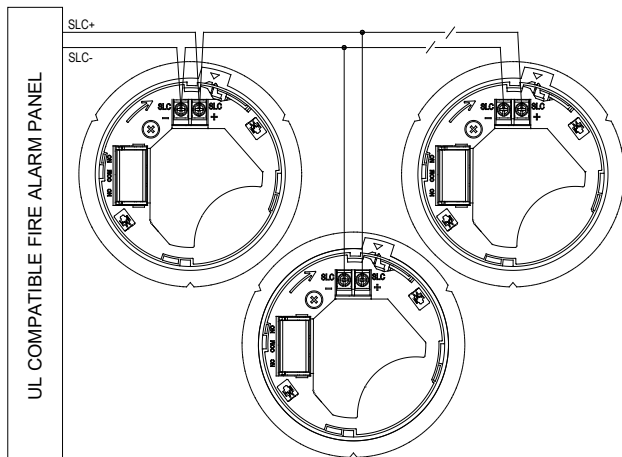

Class A and X Wiring:

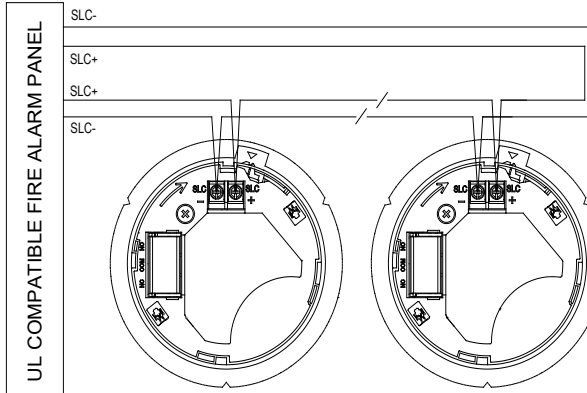

NOTE: THE BUILT-IN ISOLATION IN EACH PAD300 SERIES DETECTOR CONFIGURED IN CLASS A WITH THE SOUNDER BASE ALSO MAKES THE INSTALLATION A CLASS X.

NOTE: CLASS X REQUIRES A CLOSE NIPPLE OR CONDUIT CONNECTION TO EVERY DEVICE.

E. Locking Feature

The device includes a tamperproof feature that locks the detector and does not allow removal without the use of a tool.

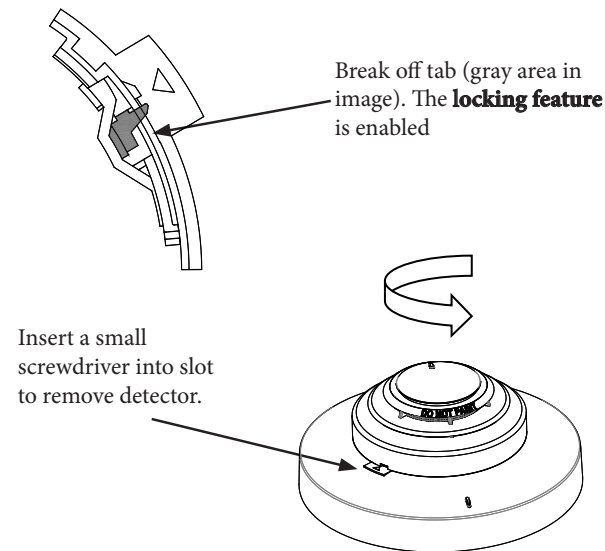

F. Warranty

POTTER warrants that the equipment herein shall conform to said descriptions as to all affirmation of fact and shall be free from defects of manufacture, labeling, and packaging for a period of five (5) years from the invoice date to the original purchaser, provided that representative samples are returned to POTTER for inspection. The product warranty period is stated on the exterior of the product package. Upon a determination by POTTER that a product is not as warranted, POTTER shall, at its exclusive option, replace or repair said defective product or parts thereof at its own expense, except that Purchaser shall pay all shipping, insurance, and similar charges incurred in connection with the replacement of the defective product or parts thereof.

The product is not intended to be serviced in the field. Return to factory for servicing. This Warranty is void in the case of abuse, misuse, abnormal usage, faulty installation, or repair by unauthorized persons, or if for any other reason POTTER determines that said product is not operating properly as a result of causes other than defective manufacture, labeling, or packaging.