

*intelligen*<sup>™</sup> / Nitrogen  
Generator

# INS-2500 (AP) Nitrogen Generator Installation, Operation, and Instruction Manual



St. Louis, MO  
800-325-3936  
www.pottersignal.com

Manual #5406823 - A  
03/26



# WARRANTY INFORMATION

## GENERAL PROVISIONS & LIMITATIONS

Potter Electric Signal Company, LLC (the “Company”) warrants to each original purchaser (“Purchaser”) of its new products from the Company or its Authorized Distributor that such products are, at the time of delivery to the Purchaser, made with good materials and workmanship. No warranty is made with respect to:

1. Any product, which has been repaired or altered in such a way, in the Companies judgment, as to affect the product adversely.
2. Any product, which has, in the Companies judgment been subjected to negligence, accident, improper storage, improper installation or application.
3. Any product, which has not been operated or maintained in accordance with the recommendations of the Company.
4. Components or accessories manufactured, warranted and serviced by others.
5. Any reconditioned or prior owned product.

Claims for items described in 4 above should be submitted directly to the manufacturer.

## WARRANTY PERIOD

The Company’s obligation under this Warranty is limited to repair or, at its option, replacing during normal business hours at the designated facility of the Company, any part that in its judgment proved not to be as warranted within the applicable Warranty Period as follows.

## COMPONENTS

All non-consumable components are warranted for 18 months from the date of shipment. Consumable are not covered under warranty. The unit must have been installed by either a factory authorized distributor or agent in accordance with the factory recommendations taking into account all other local site conditions not originally noted to the factory. The unit must be operated and maintained in accordance with the Factory recommendations and original design conditions. Failure to provide such proof of the above may void warranty.

## LABOR TRANSPORTATION & INSPECTION

The Company will repair or replace any product or part thereof which in the Companies judgment is proved to be not as warranted. Labor costs are not covered under warranty.

All costs of transportation of product, labor or parts claimed not to be as warranted and, of repaired or replaced parts to or from factory shall be borne by purchaser. The Company may require the return of any part claimed not to be as warranted to one of its facilities as designated by the Company, transportation prepaid by Purchaser, to establish a claim under this warranty.

Replacement parts provided under the terms of the warranty are warranted for the remainder of the Warranty Period of the product upon which installed to the same extent as if such parts were original components.

## DISCLAIMER

THE FOREGOING WARRANTY IS EXCLUSIVE AND IT IS EXPRESSLY AGREED THAT, EXCEPT AS TO TITLE, THE COMPANY MAKES NO OTHER WARRANTIES, EXPRESSED OR IMPLIED OR STATUTORY, INCLUDING ANY IMPLIED WARRANTY OR MERCHANTABILITY.

THE REMEDY PROVIDED UNDER THIS WARRANTY SHALL BE THE SOLE, EXCLUSIVE AND ONLY REMEDY AVAILABLE TO THE PURCHASER AND IN NO CASE SHALL THE COMPANY BE SUBJECT TO ANY OTHER OBLIGATIONS OR LIABILITIES. UNDER NO CIRCUMSTANCES SHALL THE COMPANY BE LIABLE FOR SPECIAL, INDIRECT, INCIDENTAL OR CONSEQUENTIAL DAMAGES, EXPENSES, LOSSES OR DELAYS HOWSOEVER CAUSED.

No statement, representation, agreement, or understanding, oral or written, made by any agent, distributor, representative or employee of the Company which is not contained in this Warranty will be binding upon the company unless made in writing and executed by an officer of the Company.

This warranty shall not be effective as to any claim which is not presented within 30 days after the date upon which the product is claimed not to have been as warranted. Any action for breach of this warranty must be commenced within one year after the date upon which the cause of action occurred.

Any adjustment made pursuant to this warranty shall not be construed as an admission by the Company that any product was not as warranted.

## PROMPT DISPOSITION

The Company will make a good faith effort for prompt correction or other adjustment with respect to any product, which proves to be defective within the warranty period. Before returning any product, write or call the distributor, agent or authorized company from which the product was purchased, describing defect and giving date and number of original invoice, as well as proof of Factory supplied consumable and proof of scheduled maintenance. Title and risk of loss pass to buyer upon delivery to the common carrier.

## PRODUCT SUITABILITY

Many States, Localities and Countries have codes and regulations governing sales, construction, installation, and/or use of products for certain purposes, which may vary from those in neighboring areas. While Potter attempts to assure that its products comply with such codes, it cannot guarantee compliance, and cannot be responsible for how the product is installed or used. Before purchase and use of a product, please review the product application, and national and local codes and regulations, and be sure that the product, installation, and use will comply with them.

**Potter Electric Signal Company, LLC**  
St. Louis, MO • (866) 956-0988

# CONTENTS

Safety Guidelines .....	4
Important Notice to Users .....	4
Unpacking .....	4
General Safety Information.....	4
System Overview .....	6
Key Terms .....	6
IntelliGen™ Controller.....	6
INS-2500 (AP) Exterior View.....	7
INS-2500 (AP) Interior View.....	8
INS-2500 (AP) Nitrogen Tank View.....	9
INS-2500 (AP) Air Compressor View .....	10
IntelliGen™ Display .....	11
Installation of the Nitrogen Generator .....	12
Wiring of the Nitrogen Generator.....	16
Air Compressor (380-415 VAC Three Phase) .....	16
Compressor Sensor Wire.....	17
Air Tank Blow-Down Located on the Bottom of the Tank Mounted Air Compressor (220VAC) .....	18
Nitrogen Cabinet (180-220 VAC) .....	18
Internet Connectivity, PLINK, and BMS (Optional) .....	19
Nitrogen Generator Operation .....	20
Nitrogen Functionality Test .....	22
Filling the Sprinkler System and Purging.....	23
Purging with IntelliPurge® Nitrogen Purge Valve (INS-PV) .....	24
Purging with Potter Nitrogen Purge Valve (NGP-SPV) .....	25
IntelliView™ Dashboard Internet Connectivity.....	26
IntelliPurge® Wiring and Networking .....	27
Maintenance and Part Replacements .....	28
Standard Maintenance.....	29
Compressor Air Intake Filters .....	30
Air Tank Blow-down Strainer.....	31
Lubricated Air Compressor Oil.....	31
Filter Elements .....	32
Resetting Maintenance Alert and Checking for Leaks .....	34
Air Compressor Replacement .....	34
Nitrogen Membrane Replacement .....	35
Maintenance Alerts and Actions .....	36
Trouble Alerts and Probable Causes .....	37
Troubleshooting .....	39
Leak on Sprinkler System or Nitrogen Generator .....	39
Nitrogen Flow Rate and Nitrogen Purity Test .....	39
Normal Operating Parameters of the INS-2500 (AP).....	40
Nitrogen Generator Leak Detection System.....	41
To Change the Leak Rate Warning Set Point.....	42
To Change Sprinkler System Size.....	42
INS-2500 (AP) Cabinet Dimensional Drawings.....	43
INS-2500 (AP) Air Tank Dimensional Drawings.....	44
INS-2500 (AP) Compressor Dimensional Drawings.....	45
INS-2500 (AP) Piping Instrumentation Diagram .....	46
Wiring Diagrams.....	47
INS-2500 (AP) 380-415VAC Three Phase .....	47
Menu Trees.....	48
Menu Tree 1 .....	48
Menu Tree 2 .....	49
Menu Tree 3 .....	50
Menu Tree 4 .....	51
Menu Tree 5 .....	52
Menu Tree 6 .....	53
Menu Tree 7 .....	54

## Safety Guidelines



**This manual contains safety information that is important to know and understand. This information is provided for the safety of installers, operators, and users of the Potter Nitrogen Generator as well as equipment. To help recognize this information, observe the following symbols.**

### DANGER

Danger indicates an imminently hazardous situation which, if not avoided, WILL result in death or serious injury.

### WARNING

Warning indicates a potentially hazardous situation which, if not avoided, COULD result in death or serious injury.

### CAUTION

Caution indicates a potentially hazardous situation which, if not avoided, MAY result in minor or moderate injury

### NOTICE

Notice indicates important information, that if not followed may cause damage to equipment or property.

## Important Notice to Users

The Installation, Operation, and Instruction Manual supplied with each unit must be read thoroughly and completely understood before installation and operation of the Potter IntelliGen™ Nitrogen Generator. All appropriate safety standards for handling of gases as determined by local or national laws and regulations should be followed at all times.

## Unpacking

After unpacking unit, carefully inspect all parts and equipment for any damage that may have occurred during transit. Make sure to tighten fittings, bolts, etc. before putting unit into service.

### WARNING

Do not operate if damage occurred during shipping, handling, or use. Contact Potter immediately.

## General Safety Information

**Important:** Read all of the safety information in this manual before operating this equipment. Use of the equipment in a manner not specified within this manual may impair the protection provided by the generator and could result in an unplanned release of pressure, which may cause serious injury or damage. Only competent personnel, who have been trained, qualified, and approved by Potter Electric Signal Company should perform commissioning, servicing, and repair procedures.

When handling, installing, or operating this equipment, personnel must employ safe engineering practices and observe all related local regulations, health, and safety procedures, and legal requirements for safety. Ensure that the equipment is depressurized and electrically isolated, before carrying out any of the scheduled maintenance instructions specified in this manual.

The warnings in this manual cover most known potential hazards, but by definition cannot be all-inclusive. If the user employs an operating procedure, item of equipment, or a method of working that is not specifically recommended by Potter Electric Signal Company, the user must ensure that the equipment will not be damaged or become hazardous to persons or property.

Nitrogen is not a poisonous gas. However, in a concentrated form, there is a risk of asphyxiation. The generator produces a flow of nitrogen and oxygen enriched air which quickly disperses in the atmosphere. However, do not directly inhale the output gas from the outlet pipe.

The generator is classified as non-hazardous for transportation purposes and as non-flammable for fire regulations. This equipment is for indoor use only. Do not operate outdoors.

**⚠ WARNING**

Operation of the nitrogen membrane separator above the rated design pressure may be hazardous. Do not connect it to compressed air sources that can exceed its maximum rated pressure without installing appropriate pressure controls and safety relief devices in the compressed air supply line.

Specific procedure must be developed for maintenance of the equipment on which the membrane separator is located. Appropriate labels must be continuously displayed in all areas where personnel might be exposed to a nitrogen atmosphere under normal or upset condition.

**NOTICE**

Do not attempt to disassemble the nitrogen membrane separator. Equipment damage may occur and cause the system to function incorrectly.

## System Overview

Potter IntelliGen™ Nitrogen Generators are specifically designed to provide clean, dry, high purity nitrogen for use in fire protection sprinkler systems. The generator is a fully assembled package ready to be connected to a new or existing fire sprinkler system using a factory pre-engineered air compressor. These easy-to-use systems include all air filtration equipment and controls required to keep the generator operating at peak efficiency.

The Potter IntelliGen™ Nitrogen Series operates using membrane technology. The smaller oxygen and water vapor molecules can pass through (permeate) the membrane quickly. The larger nitrogen molecules are less likely to diffuse through the separator tubes; therefore, they continue downstream to the separator outlet. The permeated molecules are discharged to the atmosphere through a vent in the separator housing.

## Key Terms

**Bypass Mode** – Most nitrogen generators cannot produce enough nitrogen to completely fill the sprinkler system in 30 minutes required by NFPA 13. Therefore, they contain valves that allow the nitrogen membrane to be bypassed so the system can be filled with compressed air. The valve setting that bypasses the nitrogen membrane is called Bypass Mode.

**Nitrogen Generating Mode** – The valve setting that allows the air to flow through the nitrogen membrane and create nitrogen is called Nitrogen Generating Mode.

**Purging** – Purging is defined as the removal of oxygen from the sprinkler system via a purge valve. The purge valve allows some gas to escape from the system which requires the nitrogen generator to supply nitrogen to maintain system pressure. This process therefore increases the nitrogen concentration within the system piping over time.

## IntelliGen™ Controller

The IntelliGen™ Nitrogen Generator Series is the only line of intelligent nitrogen generators for fire sprinkler systems. At the heart of the IntelliGen™ units, is the IntelliGen™ Controller. The IntelliGen™ Controller monitors every aspect of the nitrogen generator to ensure the unit is performing optimally. The IntelliGen™ Controller monitors pressure, runtime, power, connectivity and operational mode. Using this information and proprietary algorithms, the IntelliGen™ Controller can determine if the unit needs to be in Bypass Mode or Nitrogen Generating Mode. No need to manually change ball valve configurations or worry if the unit is producing nitrogen. Also, by monitoring the generator activity the controller can indicate the development of sprinkler system leaks, user interaction, and even if maintenance to the generator is required. Combined with the IntelliPurge® Nitrogen Purge Valve, the IntelliGen™ Nitrogen Generator is the only system that can truly monitor and protect a sprinkler system.

See Menu Tree Diagram on page 50 for more information on programming.

- The INS-2500 (AP) has a Bypass Fill Capacity of 9,028L (2,385 GAL) at 2,76 bar (276 kPa) (40 psi) and a Total System Capacity of 90,850 L (24,000 GAL).

Part Number	Model	Description
1119859	INS-2500 (AP), 380-415VAC 3PH 50HZ	IntelliGen™ Nitrogen System-2500 (AP), 380-415VAC Three Phase

### INS-2500 (AP) Exterior Cabinet View

Fig. 1

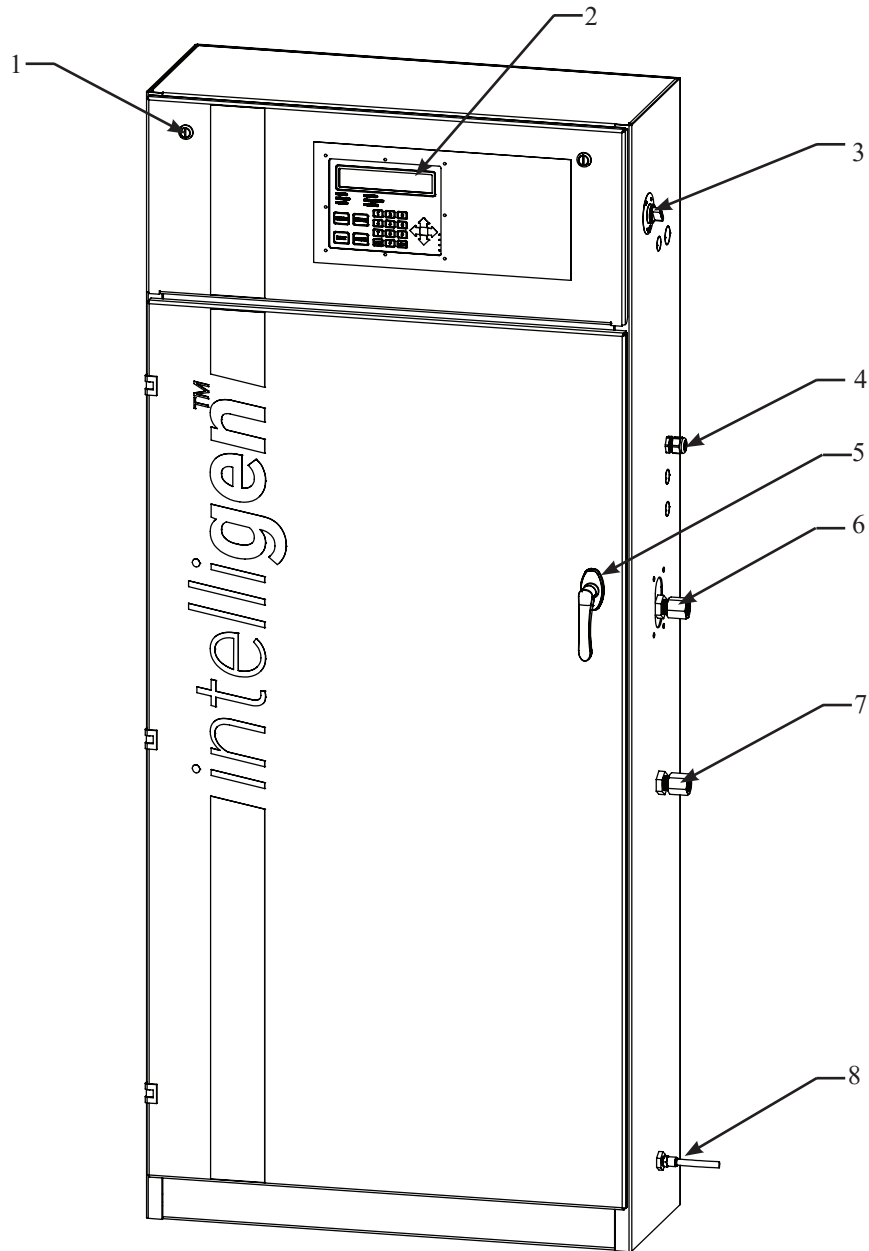

- |                                     |  |
|-------------------------------------|--|
| 1. Upper Cabinet Latches (Qty. 2)   | 5. Locking Door Handle                                       |
| 2. IntelliGen™ Display              | 6. Nitrogen Tank Connection (1/2" Female BSPT)               |
| 3. Control Power Only Switch        | 7. Air Tank Connection (1/2" Female BSPT)                    |
| 4. Compressor Sensor Wire Cord Grip | 8. 9.5mm (3/8") Drain Tube Connection (3,05m (10') Supplied) |

**INS-2500 (AP) Interior View**

Fig. 2

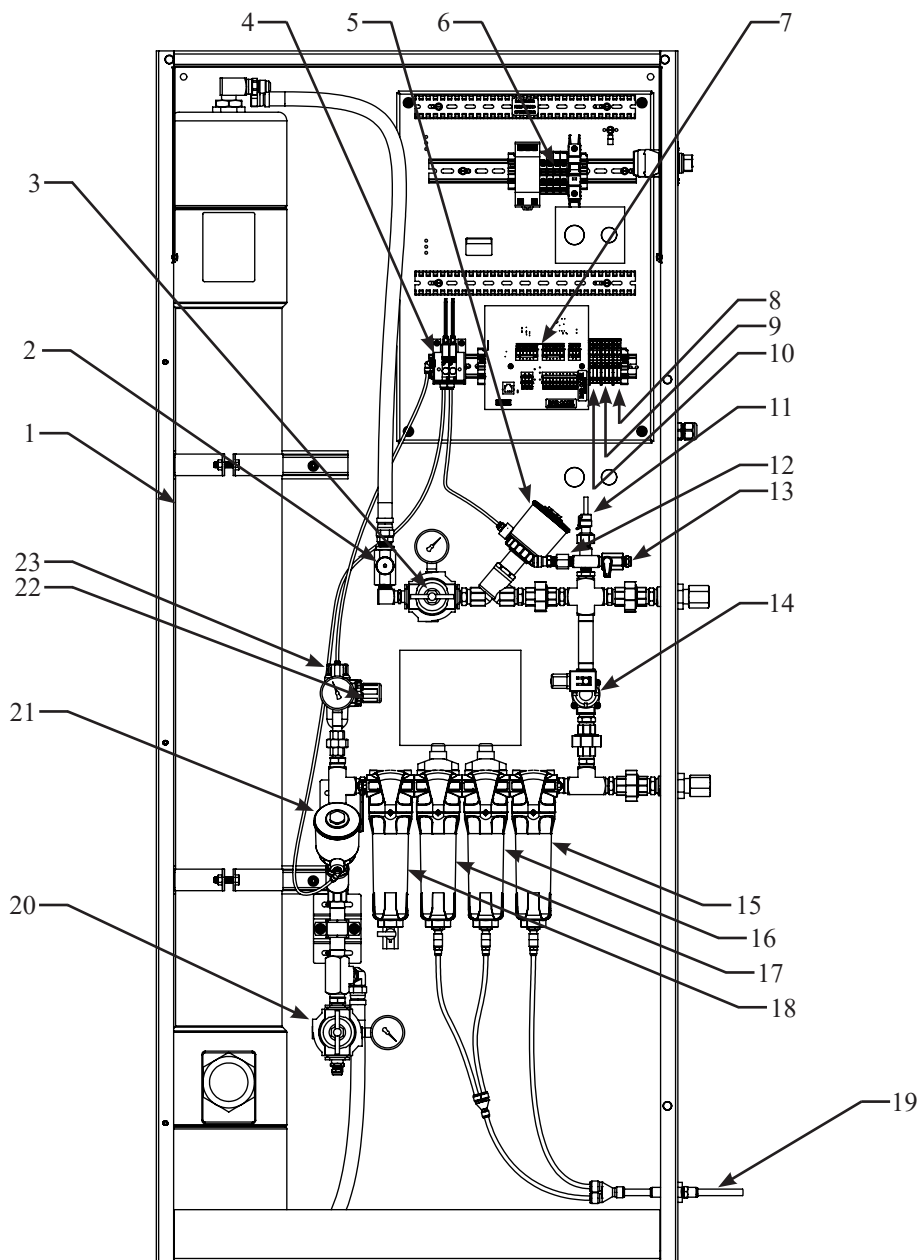

- |   |   |
|---|---|
| 1. Nitrogen Membrane (M01)                        | 13. N <sub>2</sub> Bleed Valve (V04)                    |
| 2. Flow Control Valve (FCV01)                     | 14. Bypass Solenoid Valve (XV03)                        |
| 3. Back Pressure Regulator (PRV02)                | 15. Water Separator (WS01)                              |
| 4. Instrument Air Solenoids                       | 16. Coalescing Filter 1 $\mu$ m (F01)                   |
| 5. Membrane Outlet N <sub>2</sub> Solenoid (XV02) | 17. Coalescing Filter .01 $\mu$ m (F02)                 |
| 6. Owner Supplied Power Connection                | 18. Activated Carbon Filter with Drain Valve (F03)      |
| 7. IntelliGen™ Controller                         | 19. 9.5mm (3/8") drain tubing (3,05m (10')<br>provided) |
| 8. Compressor Sensor Wire Connection              | 20. Excess Air Regulator (PRV01)                        |
| 9. PLINK Connection                               | 21. Membrane Inlet Air Solenoid (XV01)                  |
| 10. BMS Connection                                | 22. Instrument Air Regulator (PRV03)                    |
| 11. Pressure Transducer (PI01)                    | 23. Instrument Air Filter (F04)                         |
| 12. Nitrogen Sample Port (SP)                     |   |

### INS-2500 (AP) Nitrogen Tank View

Fig. 3

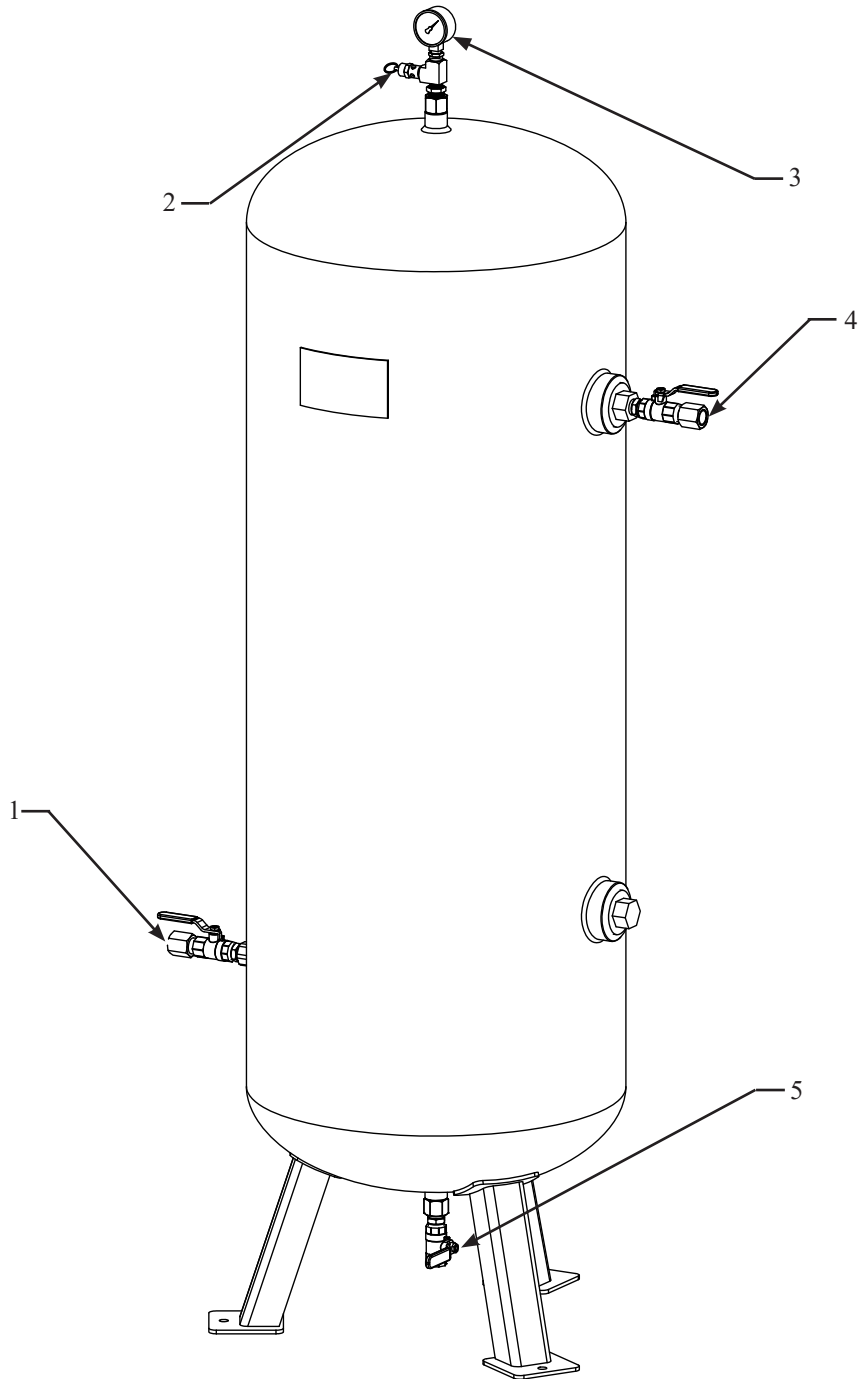

- |   |  |
|---|--|
| 1. 1/2" Female BSPT N <sub>2</sub> Tank Inlet Valve (V02) | 4. 1/2" Female BSPT N <sub>2</sub> Tank Outlet Valve (V03) |
| 2. Pressure Safety Valve (PSV01)                          | 5. N <sub>2</sub> Tank Drain Ball Valve                    |
| 3. Nitrogen Tank Pressure Gauge                           |  |

**INS-2500 (AP) Air Compressor View**

Fig. 4

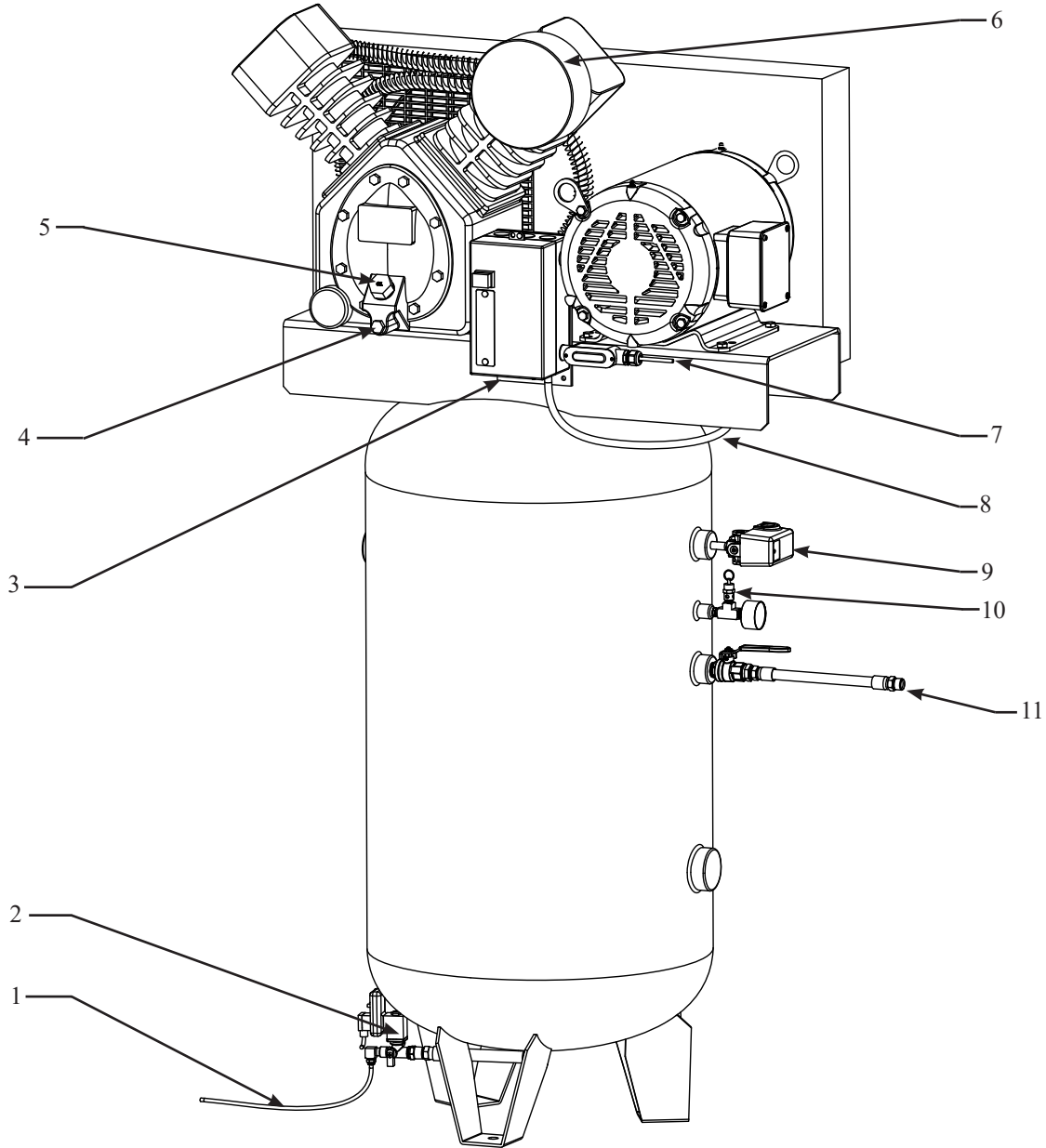

- 1. 9,5mm (3/8") Drain Tubing (3,05m (10') Provided)
- 2. Blow-Down Solenoid With Controller (230V Plug Connection)
- 3. Motor Starter
- 4. Oil Drain Plug
- 5. Oil Fill Cap

- 6. Air Compressor Air Filter
- 7. Compressor Sensor Wire (20 ft. Provided) C
- 8. To Customer's Junction Box
- 9. Air Compressor Pressure Switch
- 10. ASME Safety Relief Valve
- 11. 1/2" BSPT Air Tank Outlet Valve

**IntelliGen™ Display:**

The IntelliGen™ Display is the interface to the IntelliGen™ Nitrogen Generator. This display shows the generator's history, parameters, and troubles; as well as devices networked to the unit.

Fig. 5

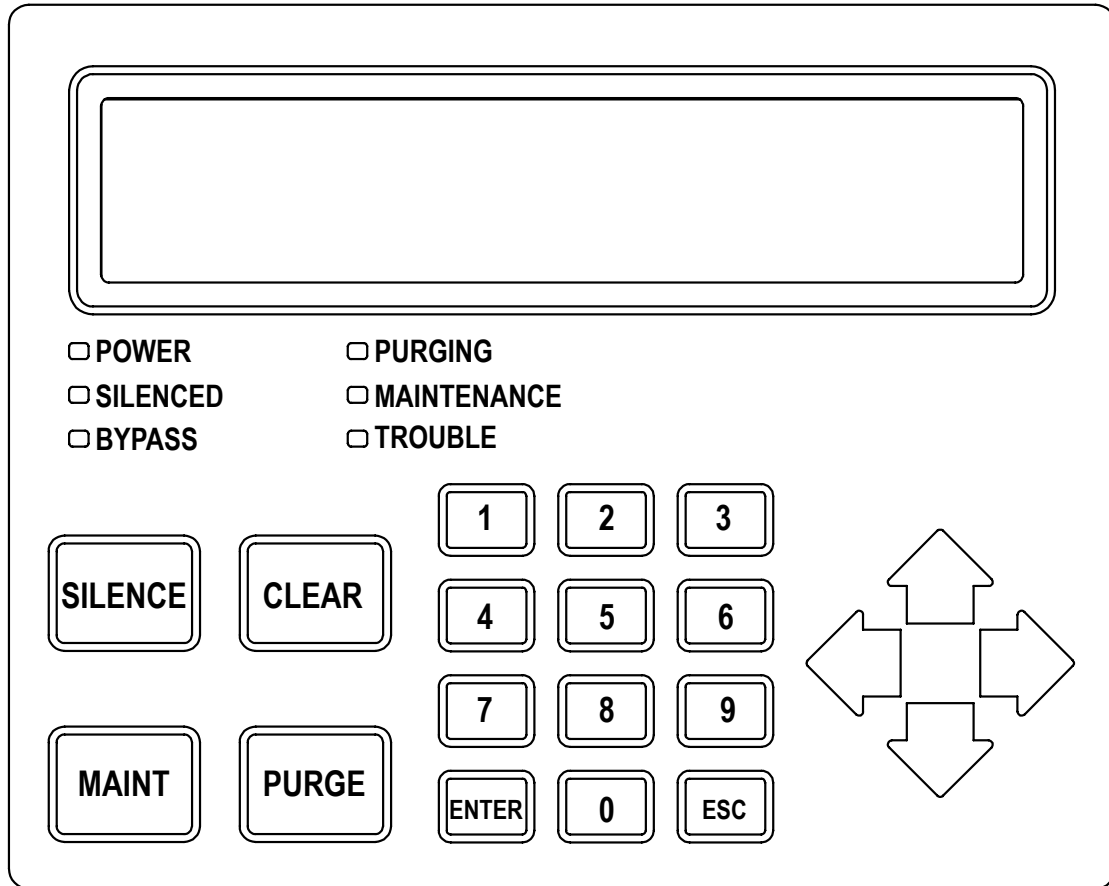
**IntelliGen™ Display LED Light Indications:**

**POWER** – The green POWER LED indicates if the IntelliGen™ Nitrogen Generator has power.

**SILENCED** – The amber SILENCED LED indicates the Trouble Horn on the IntelliGen™ Nitrogen Generator is silenced.

**BYPASS** – The amber BYPASS LED indicates if the IntelliGen™ Nitrogen Generator is in Bypass Mode. If the Bypass LED indicator is off, the unit is in Nitrogen Generating Mode.

**PURGING** – The amber PURGING LED indicates the IntelliGen™ Nitrogen Generator detects that a networked INS-PV is in a purge process.

**MAINTENANCE** – The amber MAINTENANCE LED indicates the IntelliGen™ Nitrogen Generator needs maintenance.

**TROUBLE** – The red TROUBLE LED indicates the IntelliGen™ Nitrogen Generator has a trouble condition.

**IntelliGen™ Display Button Indications:**

**SILENCE** – The "SILENCE" button will silence the Trouble Horn on the IntelliGen™ Nitrogen Generator.

**CLEAR** – The "CLEAR" button will clear all Troubles.

**MAINT** – The "MAINT" button will display the Maintenance Menu.

**PURGE** – The "PURGE" button will bring up the Purge Menu on the IntelliGen™ Display.

## Installation of the Nitrogen Generator

1. On arrival, do a full inspection by checking all packages and crates in the shipment for damage.
2. If damage is found, sign for the damage or refuse the shipment. Contact the carrier immediately and file a shipping damage claim with the carrier.
3. Check to ensure all components are contained and no visible damage has occurred during shipping.
  - Nitrogen Cabinet
  - IntelliGen™ Display
  - Tank Mounted Air Compressor
  - Nitrogen Tank
4. Each nitrogen generator requires a minimum of one Advanced Air Maintenance Device (AAMD) and one Nitrogen Purge Valve per sprinkler system. Check to see these components have arrived.
  - Advanced Air Maintenance Device (one per riser) (AAMD #1119660)
  - Nitrogen Purge Valve (NGP-SPV #1119784) or (INS-PV #1119478)
  - Portable Nitrogen Analyzer (one per job) (PNA #1119504)
5. Find a location for the nitrogen generator to be installed meeting these requirements:
  - Dry, clean and well-ventilated
  - Dimensions 1778mm x 787mm x 330mm (70" x 31" x 13") (H x W x D) for cabinet, 1829mm x 821mm x 509mm (72" x 32 3/8" x 20") (H x W x D) for nitrogen tanks and 2000mm x 1062mm x 616mm (78 3/4" x 41 3/4" x 24 1/4") (H x W x D) for tank mounted air compressor.
  - Ambient temperatures above 10° C (50° F) at all times
  - Access to front for service
  - Conveniently located near fire sprinkler system connections
  - Conveniently located near a drain
  - Near a dedicated electrical circuit with an electrical disconnect switch

6. Typical installation layout of the INS-2500 (AP). See Fig. 6.

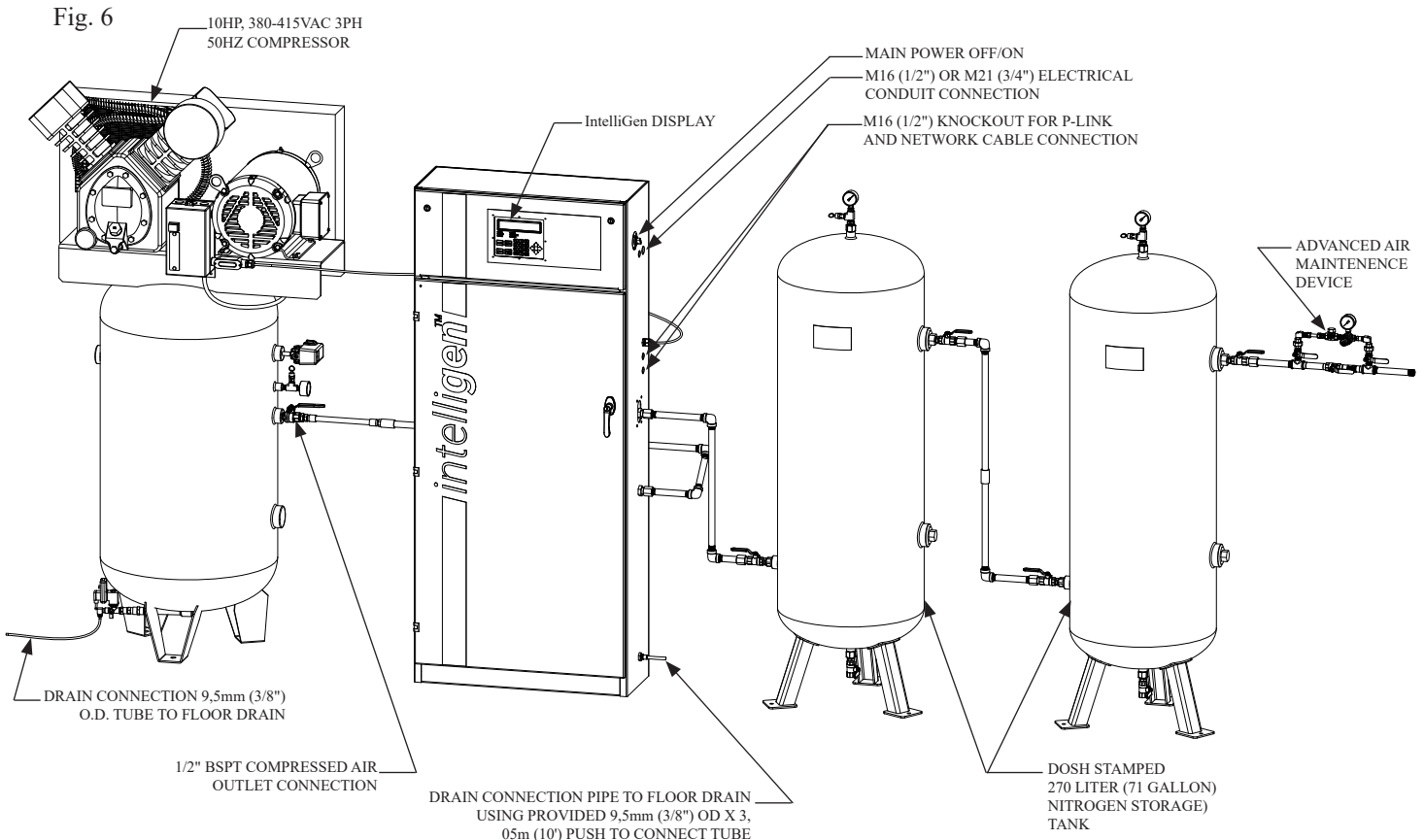

- Mount nitrogen cabinet to the floor using user supplied (4) 10mm (3/8") bolts. See Fig. 7.

Fig. 7

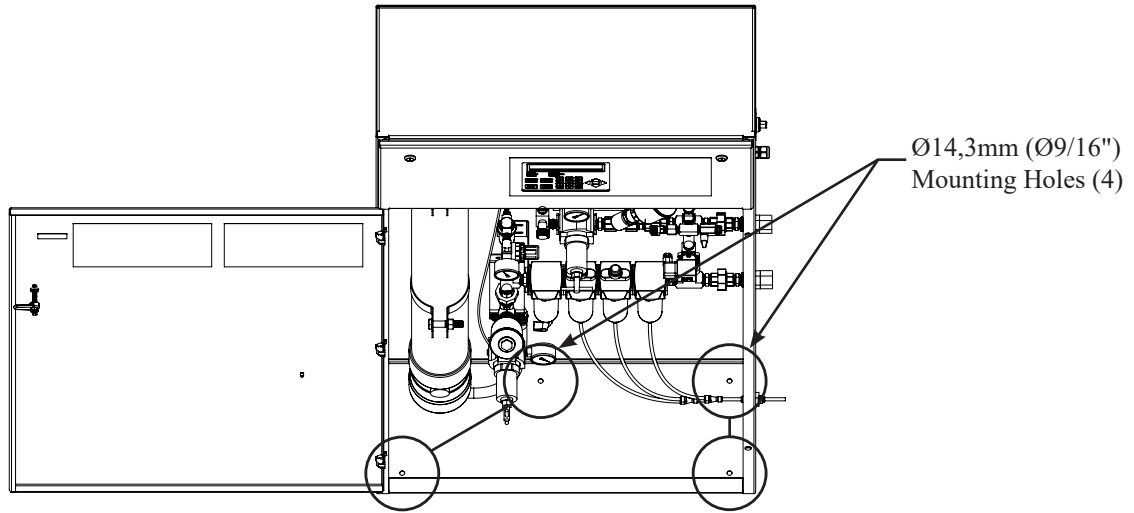

- Mount the tank mounted air compressor to the floor using the supplied vibration pads and user supplied (4) standard 10mm (3/8") bolts. See Fig. 8.

Fig. 8

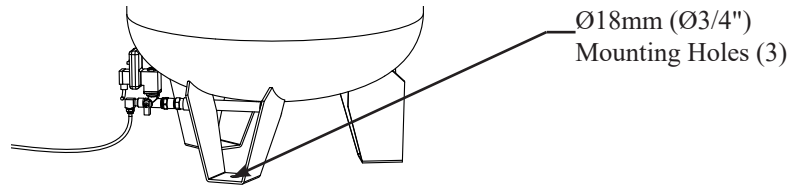

- Mount the nitrogen tanks to the floor using user supplied (3 or 4) standard 10mm (3/8") bolts. See Fig 9.

Fig. 9

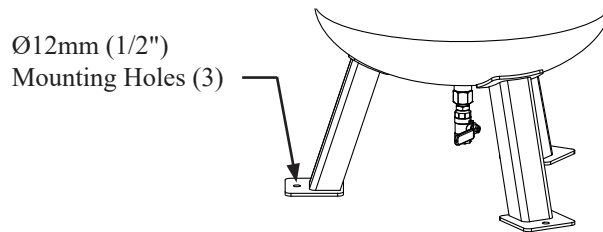

- Plumb 1/2" BSPT piping from the 1/2" Female BSPT Air Tank Outlet Valve **A** to the 1/2" Female BSPT air inlet connection **A** on the nitrogen cabinet. See Fig. 11.

Fig. 11

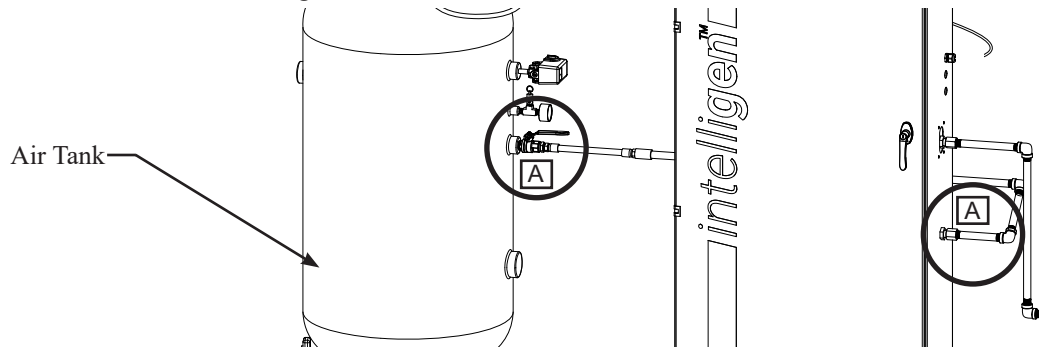

11. Install 1/2" BSPT piping from the 1/2" Female BSPT nitrogen outlet connection **B** on the nitrogen cabinet to the 1/2" Female BSPT N<sub>2</sub> Tank Inlet Valve **B** on the nitrogen tank. See Fig. 12.

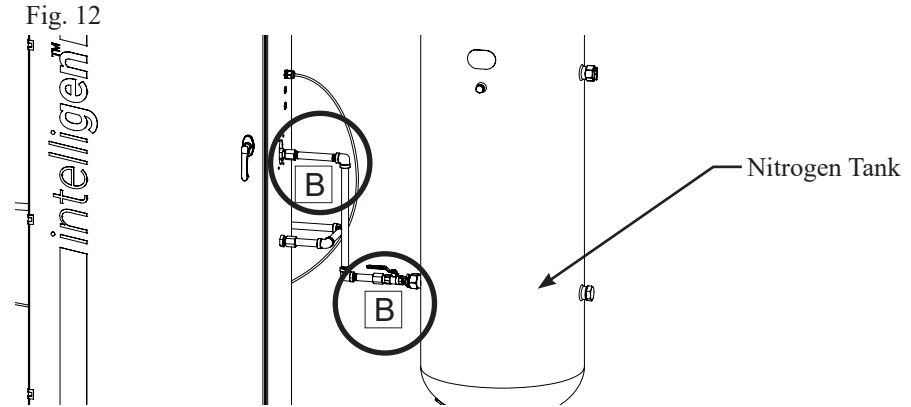

12. Install 1/2" BSPT piping from the 1/2" Female BSPT N<sub>2</sub> Tank Outlet Valve (V03) on the nitrogen tank to the Air Maintenance Device. See Fig. 13.

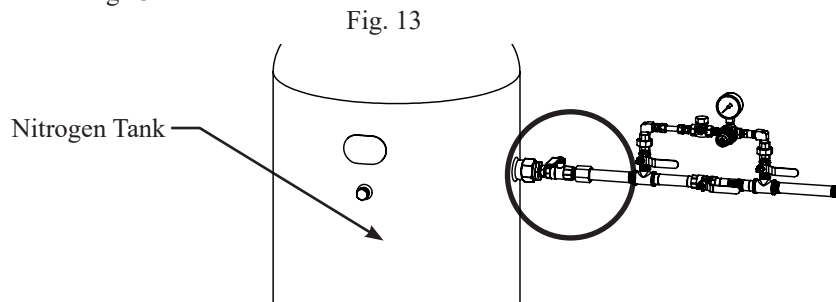

13. Install 1/2" BSPT piping from outlet of tank 1 to inlet of tank 2. See Fig 14.

Fig. 14

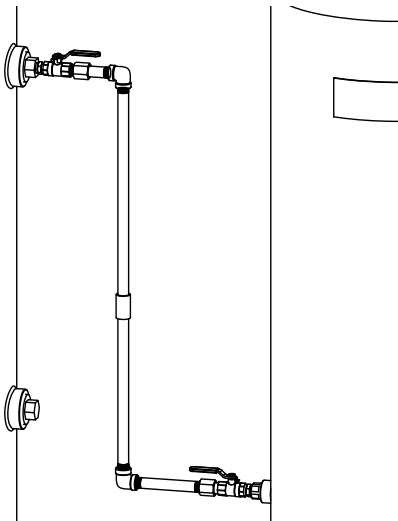

14. Pipe the provided 3,05m (10') of 9,5mm (3/8") drain tubing on the tank mounted air compressor to the floor drain in the sprinkler room. Do not pipe the drain tubing upward. See Fig 15.

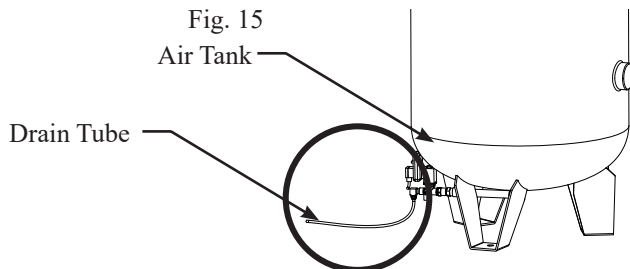

15. Pipe the provided 3,05m (10') of 9,5mm (3/8") drain tubing on the nitrogen cabinet to the floor drain in the sprinkler room. Do not pipe the drain tubing upward. See Fig 16.

Fig. 16

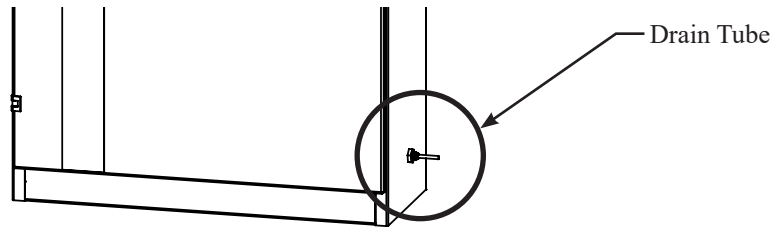

**CAUTION**

Restrain all drain tubing.

16. Each riser requires a minimum of (1) Nitrogen Purge Valve to be installed prior to implementing the Nitrogen Purging Procedure. For installation instructions, refer to Model NGP-SPV Bulletin (#5401520) or Model INS-PV Manual (#5401532) supplied with each purge valve. See Fig. 7 for NGP-SPV installation diagram. See Fig. 8 for INS-PV installation diagram.

Fig. 17

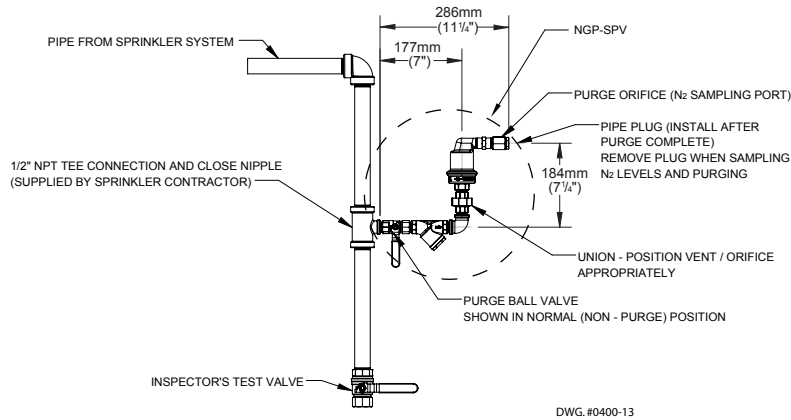
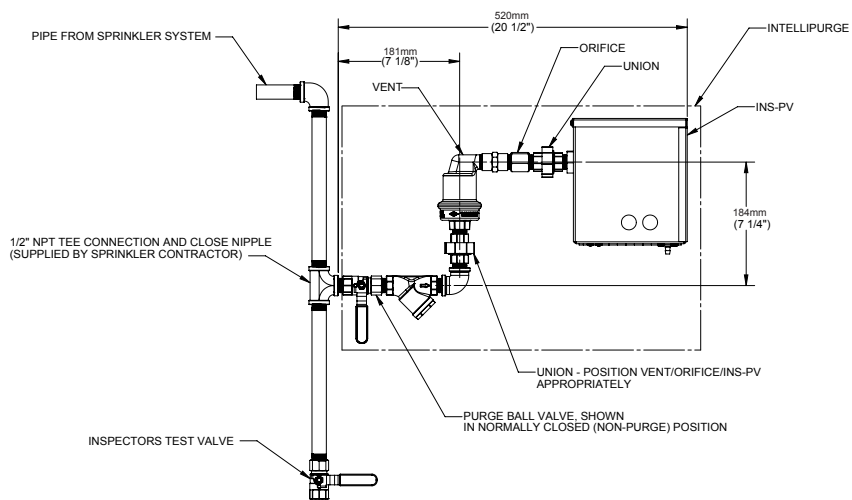

Fig. 18



**NOTICE**

Installing the purge valve upside down will not allow the system to purge. Also, ensure that there is NO water in the pipe to the purge valve.

## Wiring of the Nitrogen Generator

### NOTICE

Four items must be wired on the INS-2500 (AP) model:

- Air compressor (380-415 VAC - Three Phase)
- Air tank blow-down located on the bottom of the tank mounted air compressor (220 VAC)
- Compressor Sensor wire located on the air compressor (6,1m (20') provided).
- Nitrogen cabinet (180-220 VAC)

All wiring should be performed by a licensed electrician and conform to all applicable local standards.

### Air Compressor (380-415 VAC Three Phase)

1. Run a dedicated electrical circuit with an electrical disconnect switch to the sprinkler room.
2. Open the panel on the air compressor to access wiring connections. See Fig 19.

Fig. 19

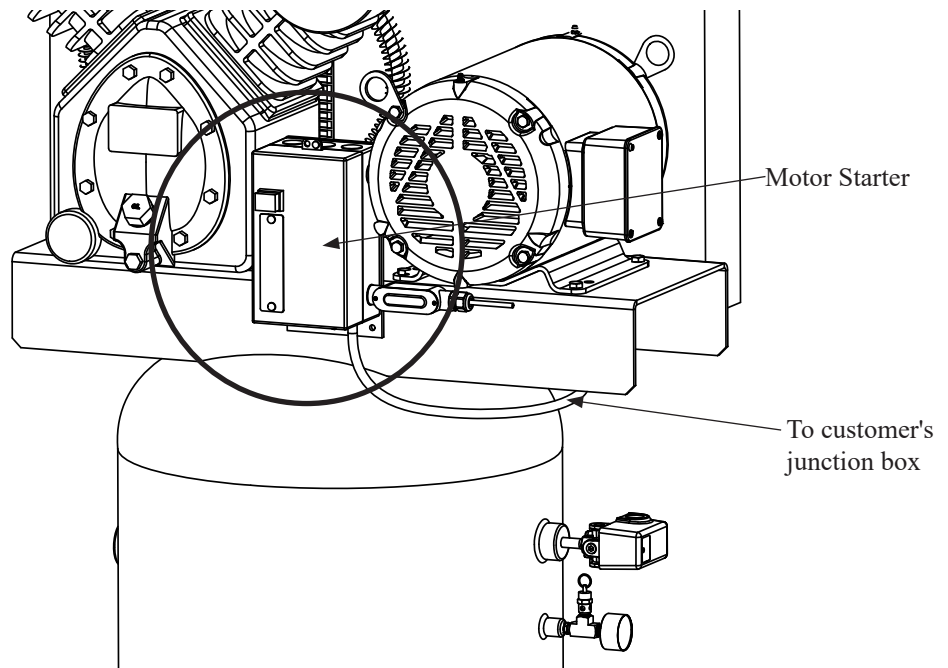

3. Depending on the voltage selected, follow the wiring diagram in this manual on page 47, or use the wiring diagram supplied with the air compressor.

### **⚠ CAUTION**

For Three Phase motors, ensure the air compressor turns in the correct direction labeled on the air compressor motor.

### Compressor Sensor Wire

1. Locate the Compressor Sensor Wire on the tank mounted air compressor. See Fig 20.

Fig. 20

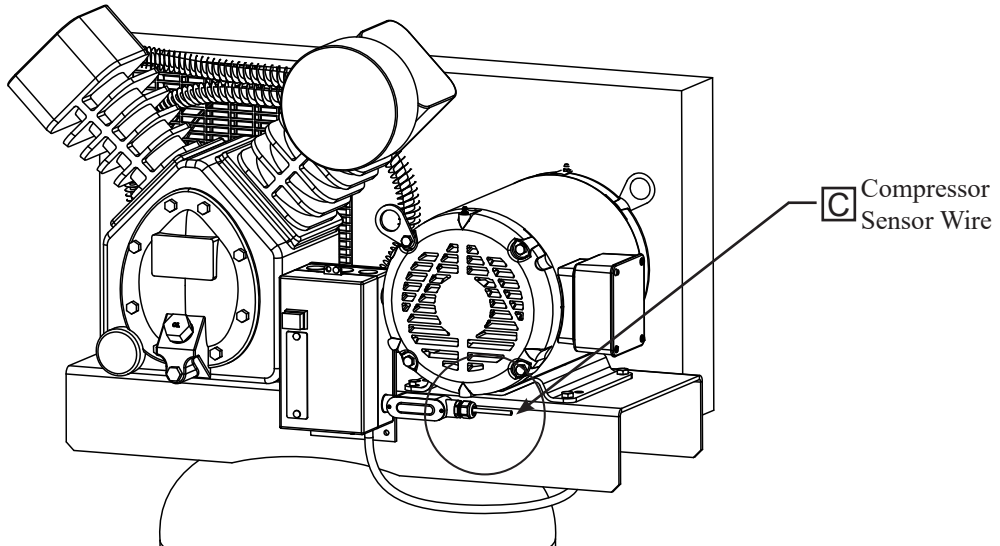

2. Run the wire to the nitrogen cabinet through the cord grip provided on the right side of the nitrogen cabinet, labeled Compressor Sensor Wire C.
3. Inside the nitrogen cabinet, connect the wires to the Compressor Sensor Wire terminal blocks. Wire the black wire to CS-B and the white wire to the CS-W. See Fig 21.

Fig. 21

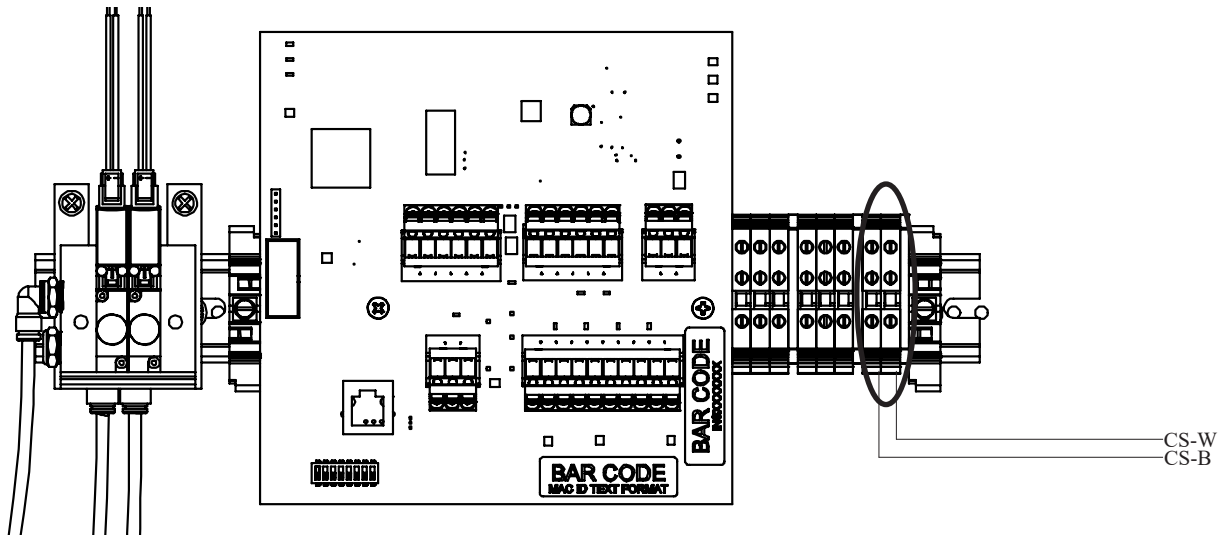

Air Tank Blow-Down Located on the Bottom of the Tank Mounted Air Compressor (220 VAC)

1. Locate the air tank blow-down on the bottom of the air tank. See Fig 22.

Fig. 22

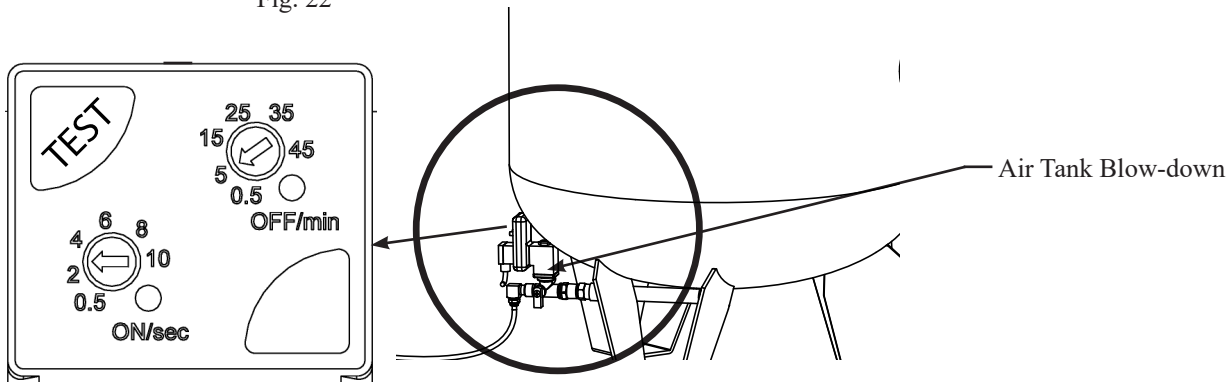

2. Using the provided 3,05m (10') of 220 VAC cord, plug the blow-down into a dedicated wall outlet.
3. Ensure the power LED is lit on the air tank blow-down.
4. The blow-down timer should be set for 3 ON/sec and 5 OFF/min.

**CAUTION**

Losing power to the air tank blow-down can cause moisture build up in the air tank and flooding of the nitrogen membrane.

Nitrogen Cabinet (180-220 VAC)

1. Run a 180-220 VAC dedicated electrical circuit with an electrical disconnect switch to the sprinkler room.
2. To wire the INS-2500 (AP) open the front panel at the top of the nitrogen cabinet to access the wiring terminal blocks. Use any of the M16 (1/2") or M21 (3/4") knockouts on the upper part of the cabinet (away from low voltage components). See Fig 23.

Fig. 23

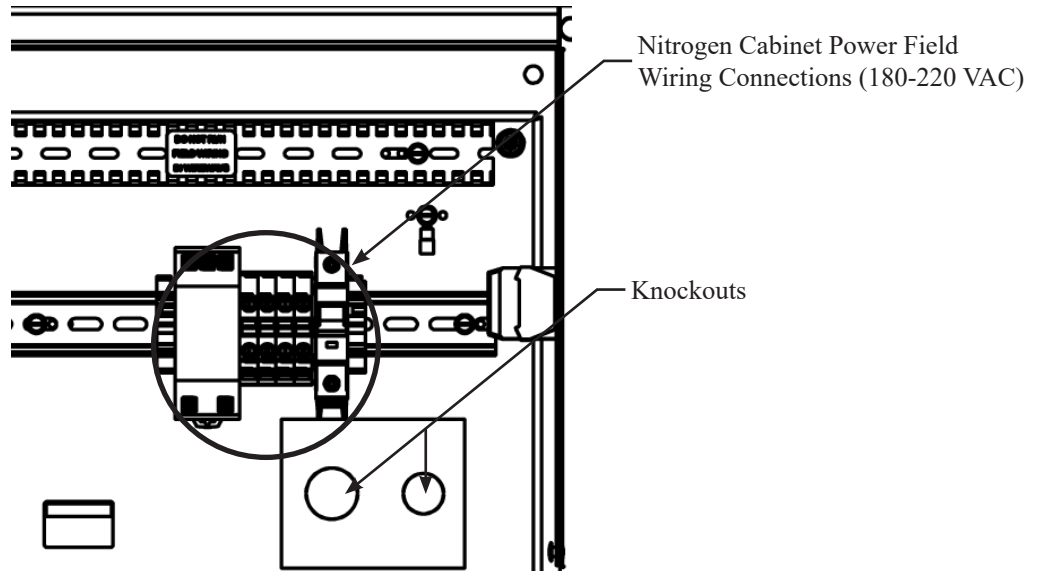

3. Follow the wiring diagram in this manual on page 47, or use the wiring diagram on the inside of the nitrogen generator cabinet.

Internet Connectivity, PLINK, and BMS (Optional)

1. For internet connectivity (see the IntelliView™ section on page 26 for more details), wire a CAT-5 Ethernet cable using a M16 (1/2") knockout on the cabinet to the Ethernet Port on the IntelliGen™ Controller. See Fig. 24.

Fig. 24

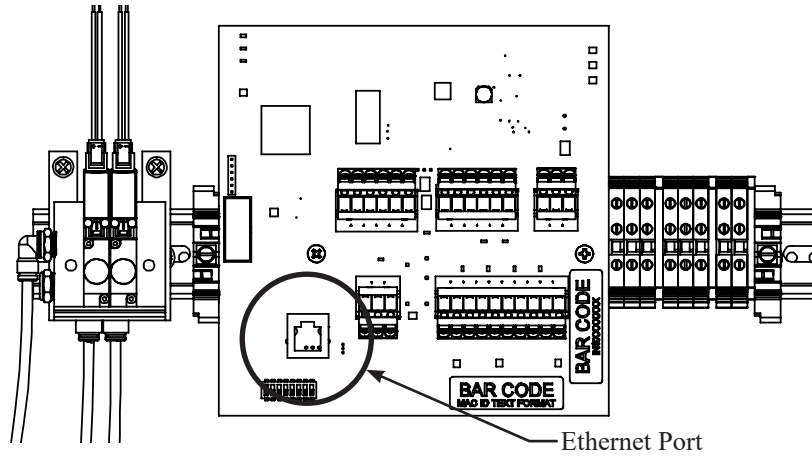

2. Using another M16 (1/2") knockout on the cabinet, wire the IntelliPurge® Nitrogen Purge Valve to the IntelliGen™ Controller using 3 wire cable. See the IntelliPurge® Section on page 27 for more details. Connect the PLINK to the terminal blocks next to the controller. See Fig. 25.

Fig. 25

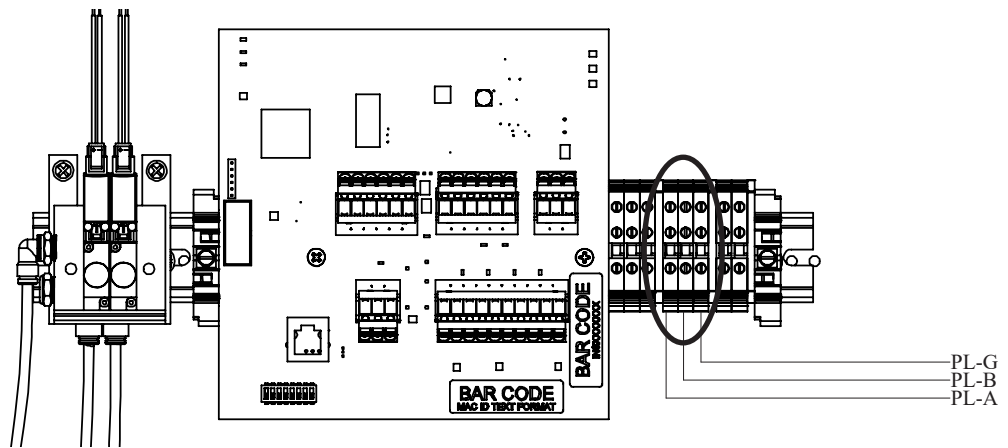

3. Using another M16 (1/2") knockout on the cabinet, wire any BMS (Building Management System) to the BMS terminal blocks. See Fig. 26.

Fig. 26

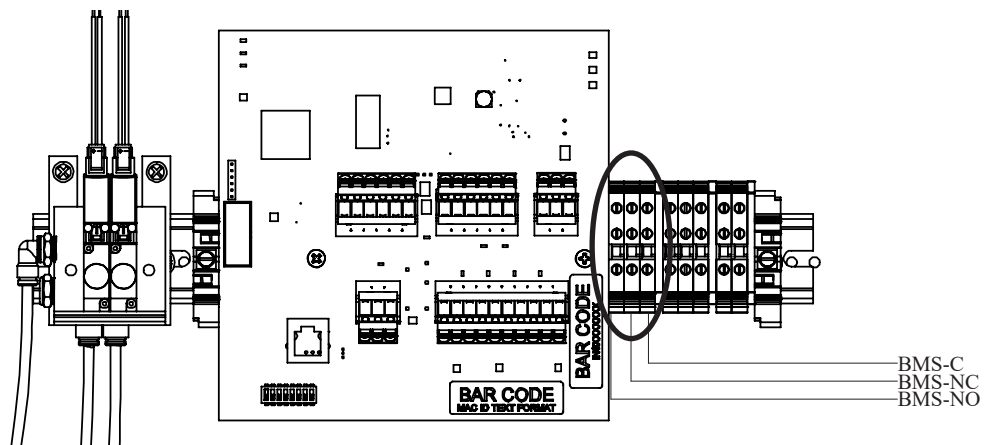

## Nitrogen Generator Operation

### Initial Set Up:

1. Before beginning, make sure the water supply to the sprinkler system is turned off.
2. Make sure all piping connections have been made in accordance with the installation instructions.
3. Ensure the Control Power Only switch located on the right side of the cabinet is in the "OFF" position.
4. Close the Air Maintenance Device. If multiple Air Maintenance Devices are used, ensure all valves are in the closed position.
5. Close the N<sub>2</sub> Tank Outlet Valve (V03) on the nitrogen tank. See Fig. 27.

Fig. 27

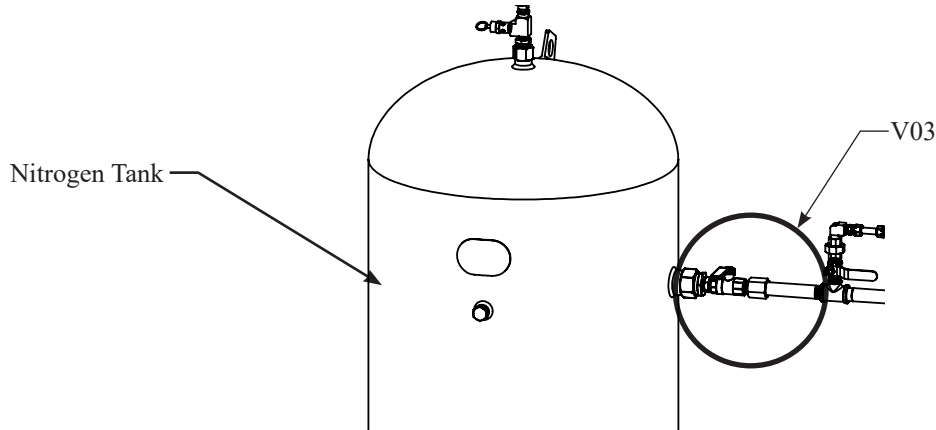

6. Turn power ON to the nitrogen generator using the Control Power Only switch on the nitrogen cabinet. See Fig. 28.

Fig. 28

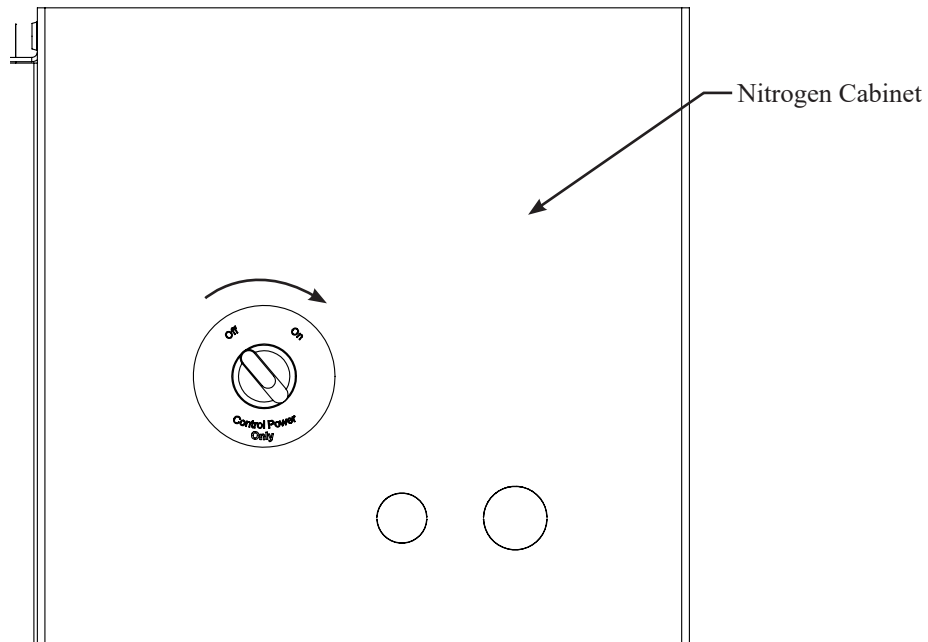

7. The IntelliGen™ Display will turn on, indicating power with a green LED labeled "POWER".

**Note:** There will be a short delay as the IntelliGen™ Display turns on and the system boots up.

8. The amber LED labeled "BYPASS" will activate if the pressure is less than 3,79 bar (379 kPa) (55 psi) in the nitrogen tank.
9. Turn power ON to the air compressor using the customer supplied electrical disconnect.
10. The air compressor will begin running and the pressure in the air tank and nitrogen tank will begin to rise. Start recording the time it takes until the compressor turns off.
11. Once the nitrogen tank pressure reaches approximately 5,52 bar (552 kPa) (80 psi) the valves inside the cabinet will close.
12. Once the air tank pressure reaches approximately 10 bar (100 kPa) (145 psi) the air compressor will turn off.
13. If the nitrogen generator is isolated from the sprinkler system:
  - The air compressor of the INS-2500 (AP) should take no longer than 10 minutes to pressure both tanks and turn off.
  - If the air compressor is not turning off, or it is taking longer than expected, go to the Troubleshooting section in this manual on page 39.
14. Once the two tanks are pressurized, the amber LED labeled "BYPASS" on the IntelliGen™ Display will turn off and "Mode" on the IntelliGen™ Display will change to "N2 Mode". This indicates that the unit is now in Nitrogen Generating Mode.
15. Check all piping connections for leaks as pre-plumbed fittings may have loosened during shipment. Any pressure drop on the tanks during this time could indicate a leak.

## Nitrogen Functionality Test:

1. To ensure the nitrogen generator is operating correctly and that the correct nitrogen purity is being produced a functional test must be performed.
2. On the inside of the nitrogen cabinet locate the blue N<sub>2</sub> Bleed Valve (V04). See Fig 29.

Fig. 29

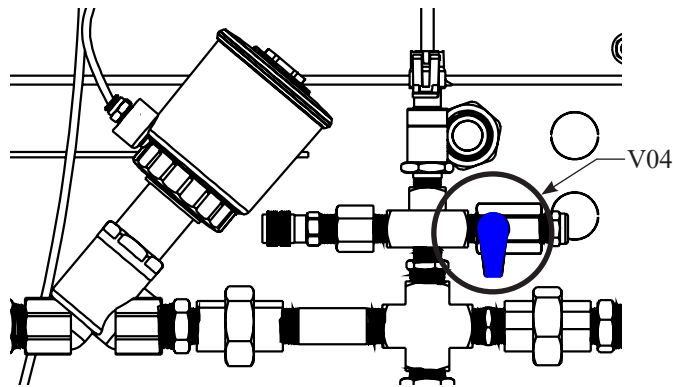

3. Slightly open the blue N<sub>2</sub> Bleed Valve and begin relieving the pressure from the nitrogen tank.
4. Quickly close the blue N<sub>2</sub> Bleed Valve when you see the red instrument air solenoid lights turn on. This will happen at approximately 4,14 bar (414 kPa) (60 psi) as show on the IntelliGen™ display. See Fig 30.

Fig. 30

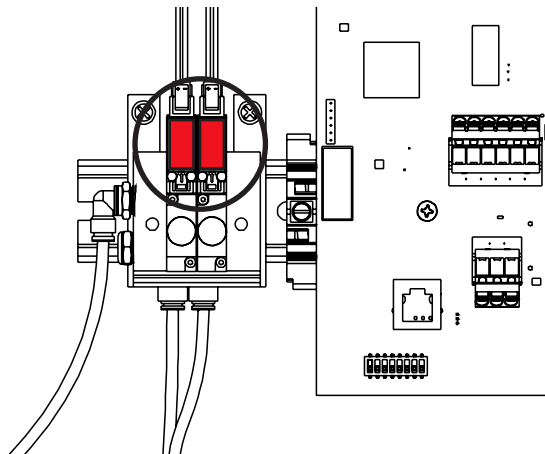

**Note:** If the pressure in the nitrogen tank drops below 3,79 bar (379 kPa) (55 psi), the IntelliGen™ Nitrogen Generator will return to Bypass Mode. Close the valve and wait for the nitrogen generator to refill the tanks and the unit to return to Nitrogen Generating Mode before trying again.

5. Immediately begin timing to see how long it takes to reach approximately 5,52 bar (552 kPa) (80 psi) in the nitrogen tank while the nitrogen generator is in Nitrogen Generating Mode.
6. If the nitrogen generator is isolated from the sprinkler system the INS-2500 (AP) should take no longer than 8 minutes to pressurize the nitrogen tank to 5,52 bar (552 kPa) (80 psi).
7. During this time, connect the Portable Nitrogen Analyzer to the Nitrogen Sample Port (SP) to measure the purity of the exiting gas. The analyzer should read 98.0% ± 1%. This may take a few minutes. See Troubleshooting Guide on Page 39 if below 98.0%.
8. When the nitrogen generator reaches approximately 5,52 bar (552 kPa) (80 psi) in the nitrogen tank, the red instrument air solenoid lights will turn off. The air compressor will continue to run until the air tank pressure reaches approximately 10 bar (100 kPa) (145 psi).

### Filling the Sprinkler System and Purging:

1. To fill the sprinkler system, open the N<sub>2</sub> Tank Outlet Valve (V03) on the nitrogen tank and open the bypass valve on the Advanced Air Maintenance Device. See Fig. 31.

Fig. 31

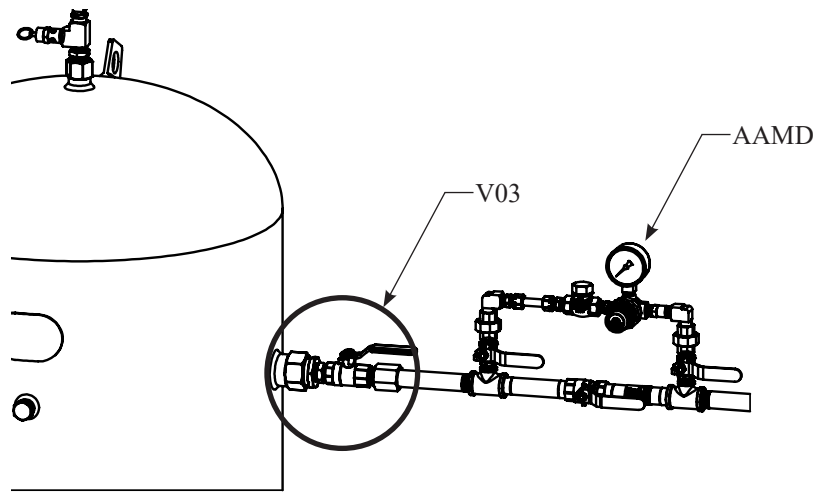

2. The pressure in the nitrogen tank and the air tank will decrease rapidly, causing the nitrogen generator to switch to Bypass Mode.
3. The amber LED labeled "BYPASS" will turn on and the "Mode" on the IntelliGen™ Display will turn to "Bypass Mode". This indicates that the nitrogen generator is filling the system with air to meet the NFPA required 30 minute fill time.
4. The air compressor will also turn on.
5. Allow the fire sprinkler system to reach the desired pressure. This should take 30 minutes or less.
6. As soon as sprinkler system supervisory pressure is reached, put the sprinkler system back into service by placing the Advanced Air Maintenance Device in the maintenance position (refer to the Advanced Air Maintenance Device manual for proper operation).

## NOTICE

Fill only one fire sprinkler system at time. Doing multiple systems at once could lead to longer compressor runtimes and possible damage to equipment. Allow air compressor to cool before beginning again.

7. When the sprinkler system(s) are completely filled, the nitrogen generator will repressurize the air tank and nitrogen tank. The air compressor will turn off and the unit will automatically return to Nitrogen Generating Mode.  
*Note:* The amber LED labeled "BYPASS" should be off and the "Mode" on the IntelliGen™ Display will display "N2 Mode".
8. Reset the Leak Rate by pressing the "MAINT" button on the IntelliGen™ Display Keypad. Enter "0000" for passcode.
9. Move the cursor to "Excessive N2 Demand" and press "ENTER".
10. Press "ENTER" on the keypad to clear maintenance alert and reset Leak Rate (LR).
11. You will receive confirmation that the alert has been cleared.
12. Press "ESC" to return to the main screen.

## Purging with IntelliPurge® Nitrogen Purge Valve (INS-PV):

Fig. 32

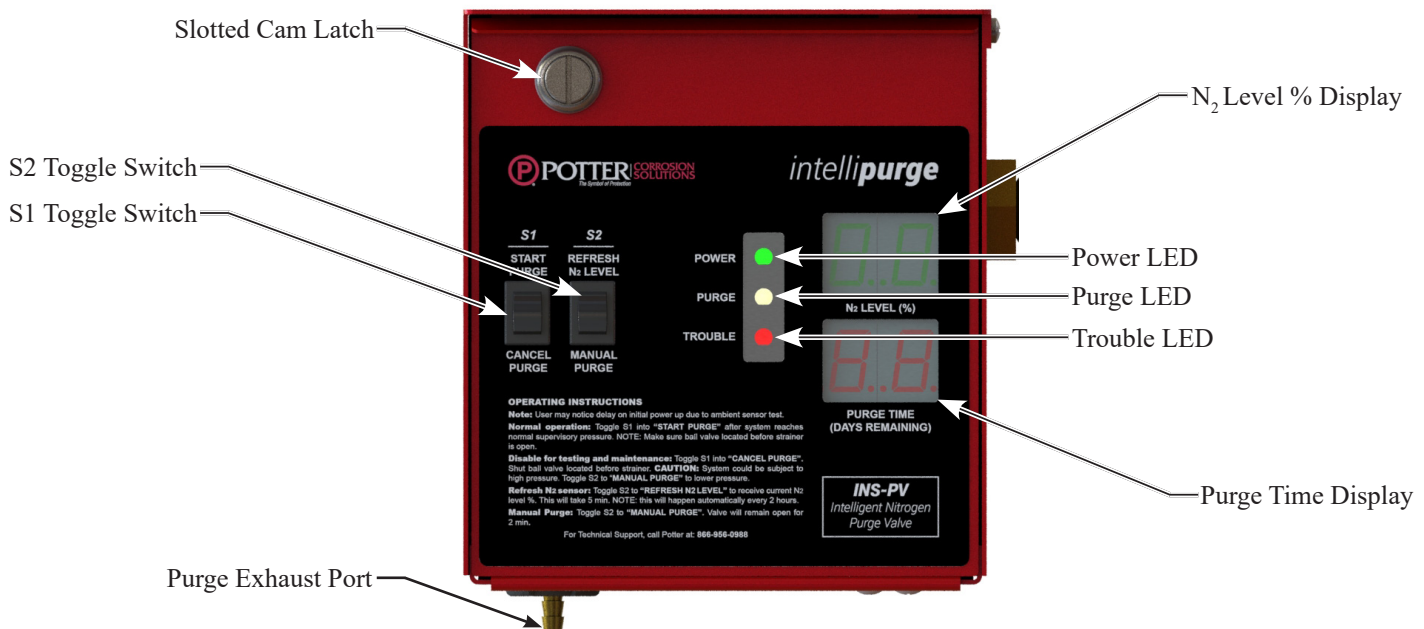

1. See Manual #5401532 for full details on installing, programming, purging and wiring of the INS-PV.
2. Go to the end of the sprinkler system(s) where the INS-PV(s) is installed. Each riser should have one INS-PV.
3. Check to ensure power is connected to the INS-PV. The green Power LED will be ON.
4. Open the ball valve on the INS-PV.
5. Ensure the INS-PV is installed properly. Installing the valve upside down will cause the unit to not purge. Any trapped water in the piping will also cause the unit to not purge.
6. To check that the INS-PV is allowing air/nitrogen flow, toggle the “MANUAL PURGE” switch ON. This will open the solenoid valves inside the unit.
7. If the sprinkler system is pressurized, listen for flow out of the Purge Exhaust Port on the bottom of the unit. You may also use your fingers to feel for flow. If no flow is present, there is a blockage such as a shut ball valve, water in the pipe, or a clogged orifice upstream.
8. If the INS-PV unit is not connected to a nitrogen generator or an INS-RA, toggle the “START PURGE” switch to start the Purge Process.
9. Once the Purge Process has started, the yellow Purge LED indicator will begin blinking.
10. The Purge Time Display will display the max number of purge days, which is the maximum amount of time the unit is allowed to purge before indicating a trouble.
11. The N2 Level display will blink indicating that it is taking an initial nitrogen level reading. After five minutes the N2 Level display should read ambient nitrogen levels, between 78-81%.
12. The INS-PV is now purging. The oxygenated air is escaping out of the Purge Exhaust Port.
13. If an IntelliPurge® Nitrogen Purge Valve (INS-PV) is connected to a nitrogen generator or an INS-PV, the S1 toggle switch will be DISABLED.
14. Return to the nitrogen generator.
15. If an INS-PV is connect to the nitrogen generator, press the “PURGE” button on the IntelliGen™ Display keypad.
16. Follow all prompts.
17. Once the system reaches 98% the INS-PV automatically closes and your system is purged.

## Purging with Potter Nitrogen Purge Valve (NGP-SPV):

Fig. 33



1. See Bulletin #5401520 for full details on installing and purging of the NGP-SPV.
2. Go to the end of the sprinkler system(s) where the NGP-SPV(s) is installed. Each riser should have one NGP-SPV purge valve.
3. Open the ball valve on the NGP-SPV.
4. Ensure the NGP-SPV is installed properly. Installing the valve upside down will cause the unit not to purge. Any trapped water in the piping will also cause the unit not to purge.
5. Unscrew the 1/2" pipe plug located at the end of the NGP-SPV.
6. Check to ensure flow is coming out the purge valve.
7. If the sprinkler system is pressurized, listen for flow. You may also use your fingers to feel for flow. If no flow is present, there is a blockage such as a shut ball valve, water in the pipe, or a clogged orifice upstream.
8. Wait approximately 14 days before returning to the job site and checking the exiting gas with the Portable Nitrogen Analyzer.
9. Check the nitrogen purity to ensure the exiting gas is  $98.0\% \pm 1\%$ .
10. If the gas is 98% purity or greater close the ball valve and screw the plug back in. The system is purged.
11. If the nitrogen purity is 85% or greater, wait another 7 days before returning to the site and rechecking. Some larger systems may have longer purge times.
12. If the nitrogen purity is around 80% it indicates that there is a blockage in the sprinkler system piping, the ball valve is closed on the purge valve or that your nitrogen generator is in Bypass Mode.

## IntelliView™ Dashboard Internet Connectivity

Potter's IntelliGen™ Controller is designed to provide you with live status updates of your nitrogen generator. The IntelliGen™ Nitrogen Generator needs to be wired using a CAT-5 Ethernet cable. The Ethernet port is located on the bottom left of the IntelliGen™ Controller. When the unit is wired and powered on, data will be accessible at [www.PotterIntelliView.com](http://www.PotterIntelliView.com).

Register your nitrogen generator, visit [www.PotterIntelliView.com](http://www.PotterIntelliView.com).

1. Log In or Register New User.
2. If you are a new user you will be required to enter your name, company information, and a valid e-mail address.
3. You will receive an e-mail confirmation with an account verification link.
4. Once logged in, click the "Register Generator" button on the Dashboard Overview page.
5. Enter the unit's MAC ID Number and the Serial Number which can be found on the IntelliGen™ Controller inside the cabinet. See Fig. 34.

Fig. 34

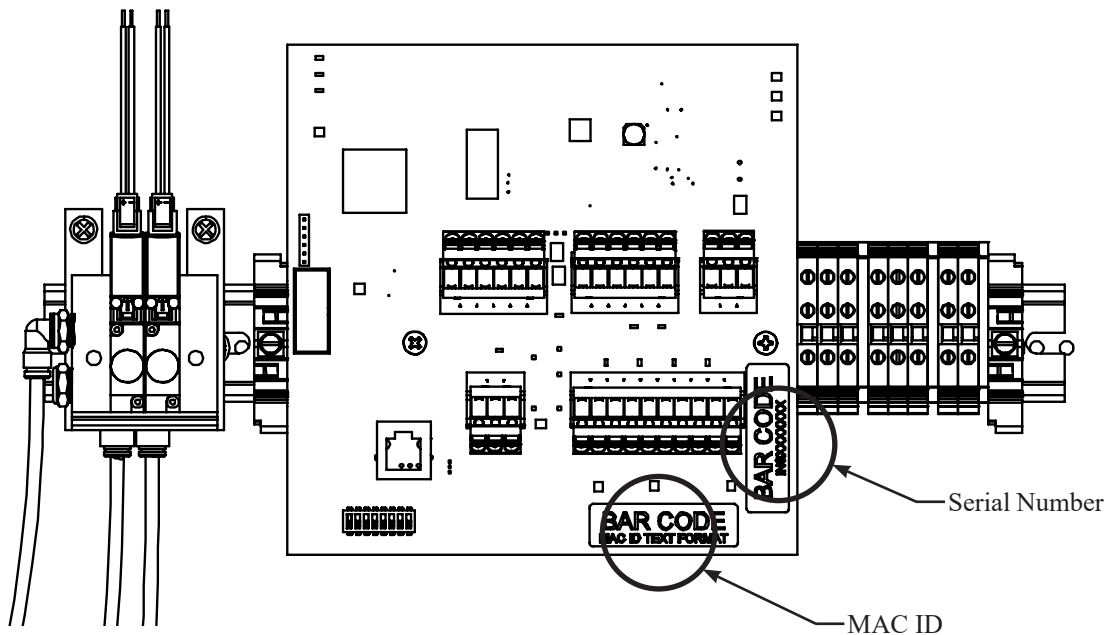

6. Add a name for the generator and the building where the generator is located.
7. A window will appear indicating that you have successfully added the nitrogen generator. Click save.
8. The page will refresh with information on the new nitrogen generator.
9. For more information on the Potter IntelliView™ Dashboard, watch a tutorial at [www.potterintelliview.com](http://www.potterintelliview.com)

## IntelliPurge® Wiring and Networking

1. The PLINK network is Potter’s propriety networking connection. It is a RS-485 network for serial communication between the Nitrogen Generator (INS Series) and its Purge Valves (INS-PV).
2. PLINK requires 3 signal lines to allow communication to and from the Nitrogen Generator and the Purge Valves.
  - PL-A
  - PL-B
  - PL-G

Recommended wire is an unshielded 24 AWG stranded CAT5 equivalent or higher rated network cable.

Fig. 21

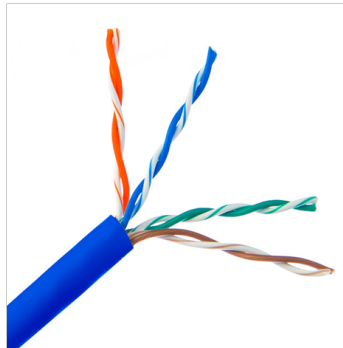

- PL-A is the blue wire
- PL-B is the white/blue wire
- PL-G is the orange wire

### NOTICE

The other 5 wires are not needed in this application

3. We recommend the unused conductors from the network cable be pulled back and taped against the outer jacket for possible future use.
4. Maximum number of INS-PV devices networked to an IntelliGen Series Nitrogen Generator is 26. The maximum wire length for the network when using the recommended wire is 4000 Ft. Contact technical support for further assistance if a longer wire length is required.
5. The PLINK network works as a Master and Slave network. The INS generator is defined as the Master.

## PLINK Wiring Schematic

Fig. 22

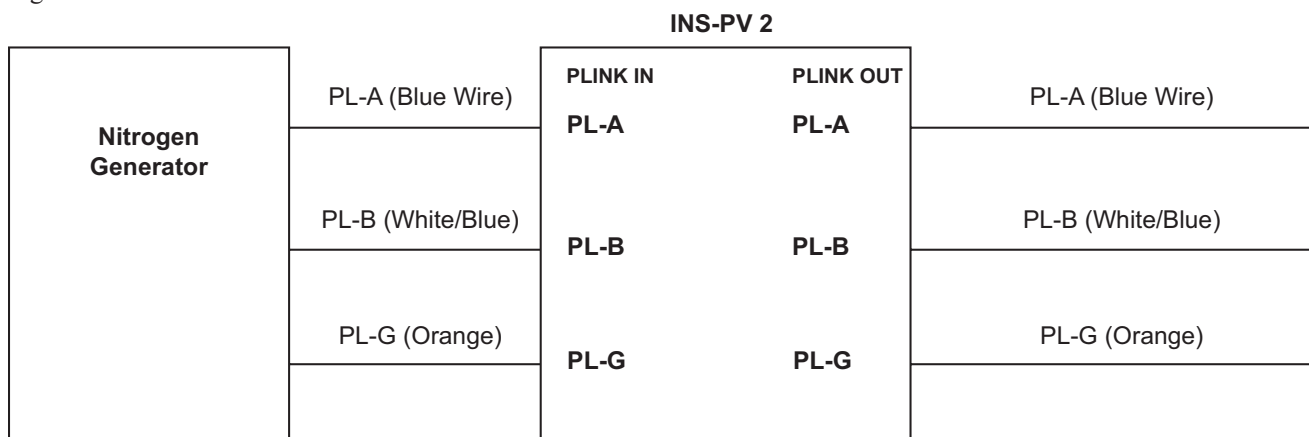

### NOTICE

The first INS-PV in the network when connected to the nitrogen generator should be addressed INS-PV-2. The last INS-PV in the network must be addressed as INS-PV-27. If Only (1) INS-PV is networked to the generator it must be addressed as INS-PV-27

## Maintenance and Part Replacements

Potter IntelliGen™ Nitrogen Generators are designed to provide maintenance alerts that ensure the long life of the nitrogen generator. These alerts also ensure that the unit runs at peak efficiency. The IntelliGen™ Nitrogen Generator has an internal maintenance timer that monitors how long the unit has been operating since it has been serviced.

When the system needs maintenance, the amber maintenance light on the IntelliGen™ Display will turn on. If connected to the internet, you will receive an e-mail notification as well. If maintenance on the nitrogen generator is not done within 250 compressor operating hours, the nitrogen generator will show a trouble condition.

To reset the maintenance timer and get the maintenance alert to reset, go to the IntelliGen™ Display.

1. Press "MAINT" on the IntelliGen™ Display keypad.
2. Enter passcode "0000".
3. Select "Std. Nitrogen Maintenance" by moving the cursor and pressing "ENTER".
4. The menu will then display the count down hour log on the Maintenance Timer. Press "ENTER" on the keypad to clear Maintenance Timer.
5. The amber Maintenance LED will turn off.

### CAUTION

All pressure must be relieved from the entire nitrogen generator system BEFORE servicing. To avoid system damage and/or personal injury, the nitrogen generator should be isolated from the sprinkler system and the generator system fully depressurized before any maintenance or service is performed. All maintenance and troubleshooting activities for the Potter Nitrogen Generator should be performed by qualified personnel using reasonable care. Before servicing, isolate all risers by closing all Advanced Air Maintenance Device valves and relieving all system pressure from the Potter Nitrogen Generator. Failure to do so could result in serious injury or death. Ensure power is turned off at the electrical disconnect.

#### Break In Oil Change - First 100 Hours:

- Change Compressor oil (All Season Select, see owners manual #7348130000)
- Check activated carbon and coalescing filter elements. Replace if necessary.

#### 500 Compressor Operating Hours:

- Change compressor oil (All Season Select, see Ingersoll Rand owners manual #7348130000).
- Clean compressor intake filter.

#### 1000 Compressor Operating Hours:

- Change compressor oil (All Season Select, see Ingersoll Rand owners manual #7348130000).
- Replace the activated carbon and coalescing filter elements.
- Clean the air tank blow-down strainer screen.
- Replace the air compressor intake filter elements.

#### Annual Inspection:

- Check for unusual noise or vibration.
- Clean all external parts of the compressor and motor.
- Manually test safety relief valves.
- Inspect system for leaks.
- Tighten fittings, nuts and screws as required.
- Check the pressure settings.
- Check the nitrogen purity using Portable Nitrogen Analyzer. It should be 98.0% ± 1%.

Part Number	Maintenance Parts Description
0090222	KIT-MAINTENANCE IR OIL / AIR FILTER IR COMPRESSOR INTAKE INS-1500/2000/2500 (EU/AP) (Due to alternate filter assemblies, verify kit part number on label located near filter assembly in cabinet.)
0090258	KIT-MAINTENANCE WORKHORSE OIL / AIR FILTER WORKHORSE COMPRESSOR INTAKE
0090262	KIT-FILTER ELEMENT REPLACEMENT INS-1500/2000/2500

Part Number	Replacement Parts Description
1119504	PORTABLE NITROGEN ANALYZER
1119646	MEMBRANE SEPARATOR-INS 2500
1119603X	COMPRESSOR, 10 HP, 380-415VAC 3PH 50HZ (INS-1500/2000/2500 (AP))

## Standard Maintenance

### Tools Needed:

- Adjustable wrench
- Channel Lock
- Rag
- Filter Element Replacement Kit (#0090262)
- Compressor Oil and Air Intake Filter Kit (Ingersoll Rand owners manual #1348130000)

## ⚠ WARNING

Drain all pressure from the nitrogen generator before proceeding and turn off power to unit at the contractor installed electrical disconnect.

1. Power off the nitrogen cabinet using the Control Power Only Switch located on the right side of the cabinet.
2. Power off the air compressor using the customer supplied electrical disconnect switch.
3. Isolate the nitrogen generator from the sprinkler system by closing the N<sub>2</sub> Tank Outlet Valve (V03) located on the nitrogen tank. See Fig. 37.

Fig. 37

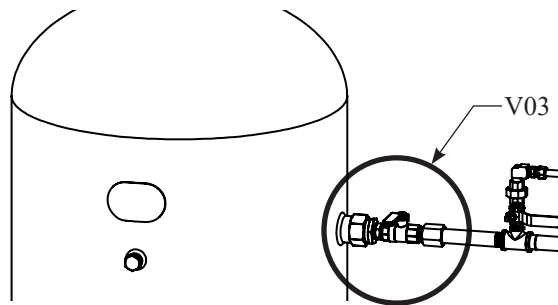

4. Open the blue N<sub>2</sub> Bleed Valve (V04) located near the Nitrogen Sample Port (SP) and begin draining pressure from the nitrogen tank. See Fig. 38.

Fig. 38

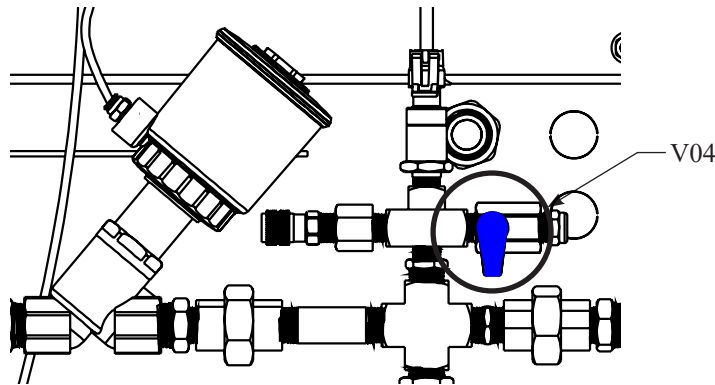

5. Open the black handled valve located on the Activated Carbon Filter (F03) and begin draining pressure from the air tank. See Fig. 39.

Fig. 39

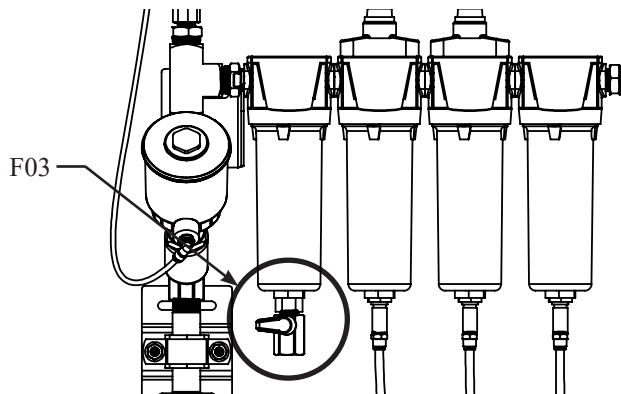

Compressor Air Intake Filters:

6. When the pressure has been drained from the nitrogen generator replace the air intake filter element.
7. Loosen wing nut and remove lower air filter cover from compressor. See Fig. 40

Fig. 40

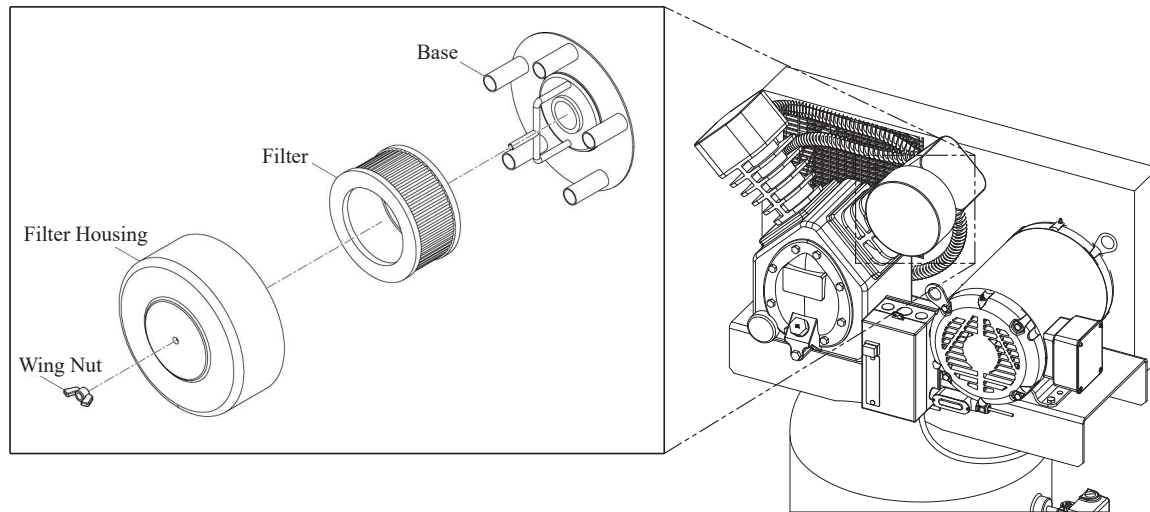

8. Remove used air intake filter element.
9. Replace with the new air intake filter element.
10. Return the lower air filter cover and tighten the wing nut to secure the cover

Lubricated Air Compressor Oil:

11. Remove oil fill cap.
12. Remove drain plug from oil drain port and drain oil into suitable container.
13. Reinstall drain plug.
14. Place funnel into oil fill port and add oil until it reaches the level indicated on the indicator glass.
15. Replace oil fill cap.

Fig. 41

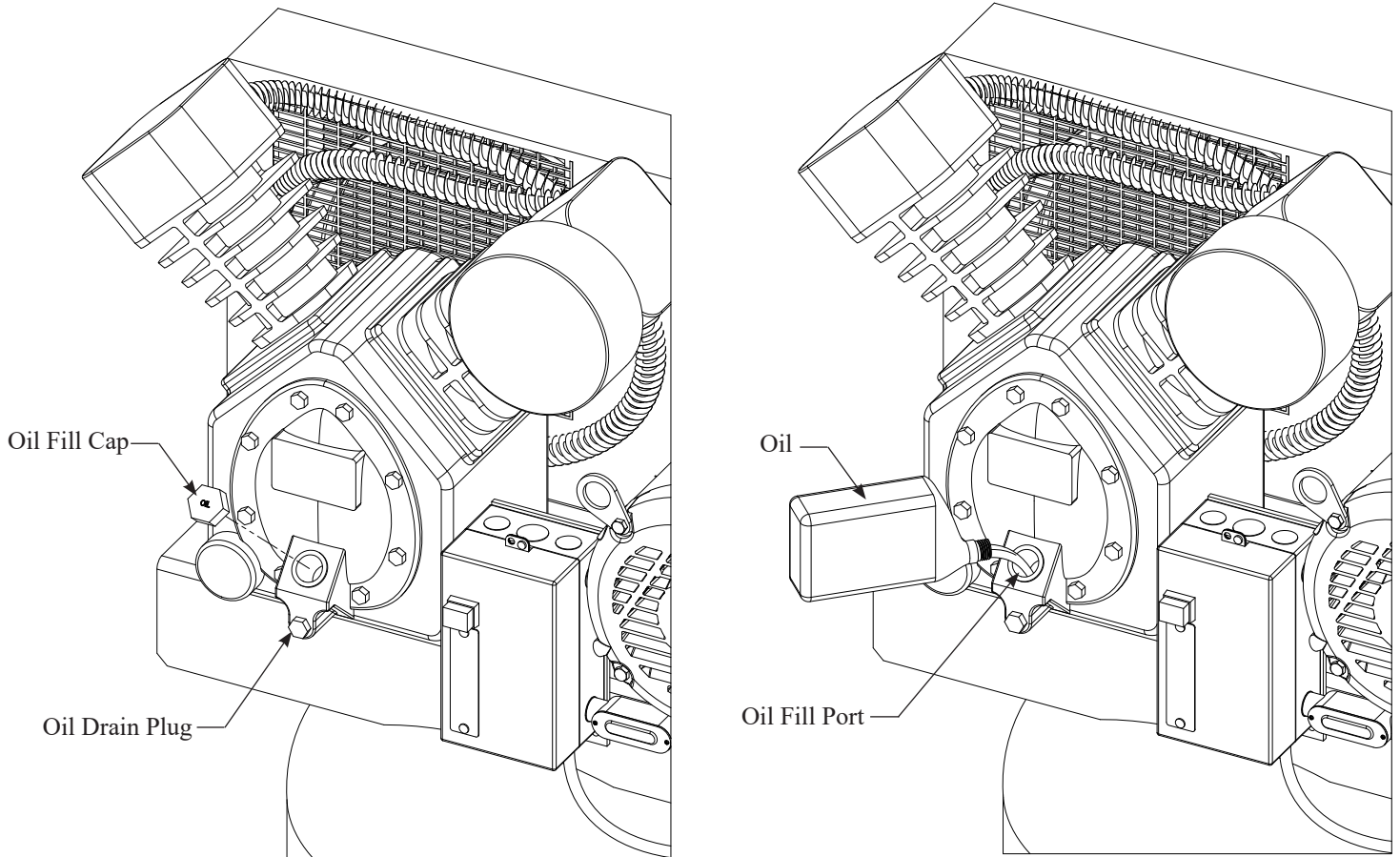

Filter Elements:

16. Locate the four (4) filters on the inside of the nitrogen generator cabinet. See Fig. 42.

*Note:* The Water Separator labeled WS01 does not have a replaceable element.

Fig. 42

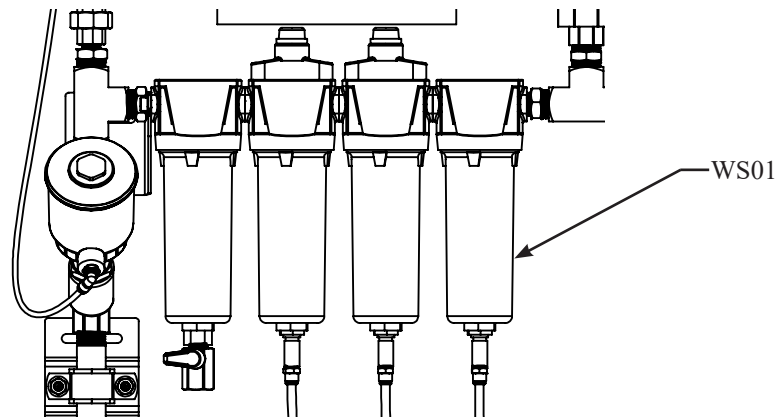

17. Disconnect the drain tubes from the filter bowl by pushing up on the plastic releasing collar and pulling down on the tube. See Fig. 43.

Fig. 43

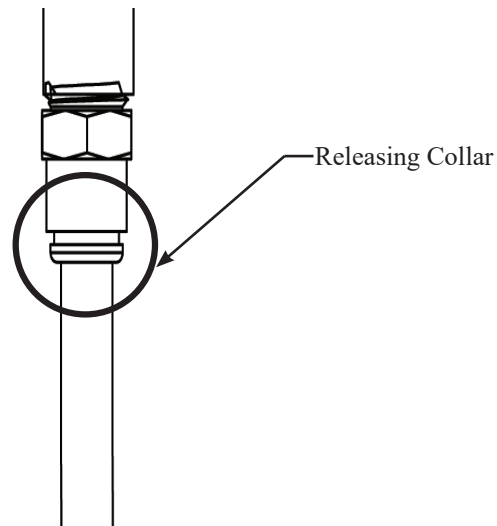

18. Using an adjustable wrench loosen the filter bowl from the filter body. See Fig. 44.

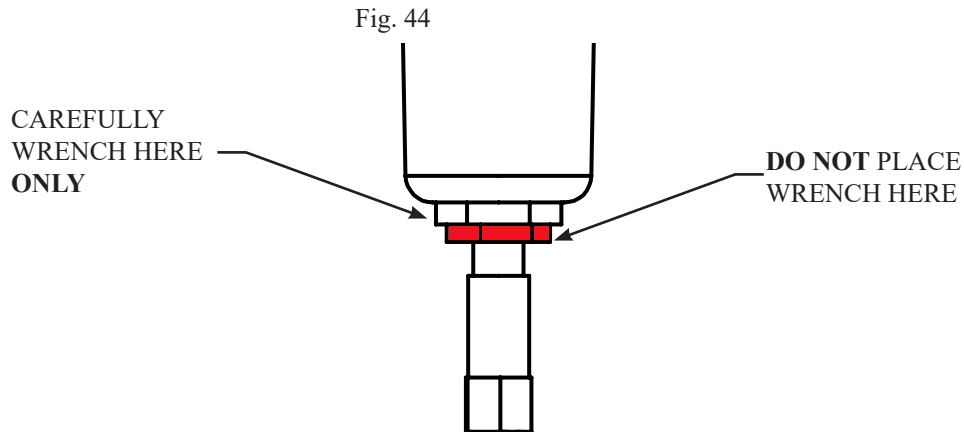

**⚠ CAUTION**

It is extremely important that you only unscrew the drain bowl from the filter body. The float adjustments at the bottom must remain in auto. Manual (man) will cause the floats to remain open and air to leak. If you accidentally loosen the float adjustment, simply retighten with your hand. See Fig. 45.

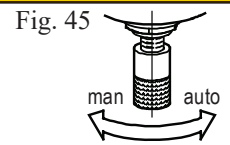

19. After the filter bowl is separated from the filter body, remove the filter element by gently pulling down. See Fig. 46.

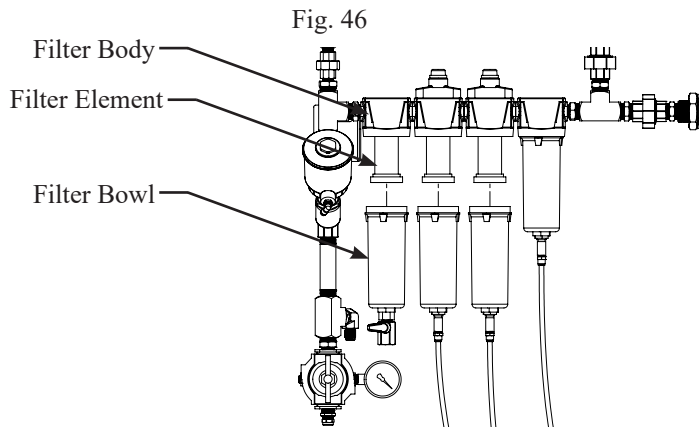

20. Replace the filter element with the correct filter element from the replacement kit (#0090262). See Fig. 47.

- a. Water Separator (5230027) - No Element
- b. The filter body (#5230028) second from the right is the 1 micron filter which has a RED element (#5230032).
- c. The filter body (#5230029) third from the right is the .01 micron filter which has a BLUE element (#5230033).
- d. The filter body (#5230030) on the far left is the activated carbon filter which has a BLACK element (#5230034).

**Note:** This filter bowl is not connected to the drain and has a black handled valve.

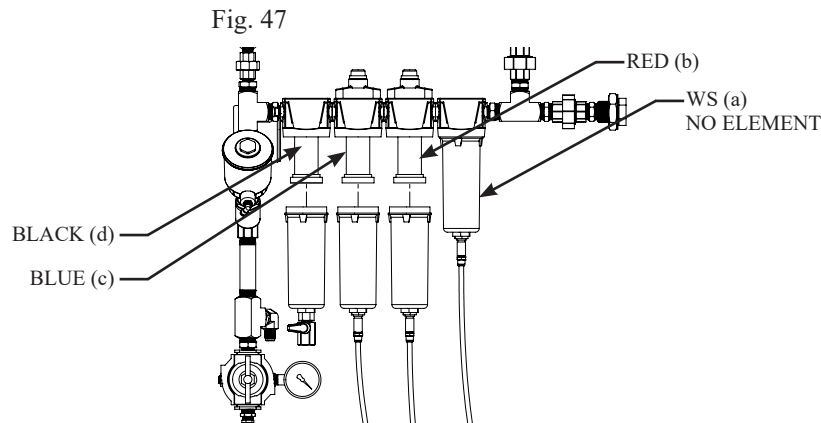

21. Remove old O-rings and replace with the O-rings in the filter element kit.
22. Clean filter bowls of debris.
23. Screw the filter bowl back into the filter body. Use a small spanner wrench to tighten the correct wrenching flats. Be careful to not over tighten or you may crack the filter body. Repeat for all filters.
24. Close the black handled ball valve on the Activated Carbon Filter (F03) and the blue N<sub>2</sub> Bleed Valve (V04).

#### Resetting Maintenance Alert and Checking for Leaks:

25. Turn power on to the nitrogen generator using the Control Power Only switch.
26. To reset the maintenance timer and get the maintenance alert or maintenance trouble to reset, go to the IntelliGen™ Display.
27. Press "MAINT" on the IntelliGen™ Display keypad.
28. Enter passcode "0000"
29. Select "Std. Maintenance" by moving the cursor and pressing "ENTER".
30. The menu will display maintenance timer countdown hours. Press "ENTER" again to confirm.
31. To reset the maintenance timer press "ENTER".
32. The maintenance light on the IntelliGen™ Display will turn off and the maintenance timer has been reset.
33. Turn power back on to the air compressor using the electrical disconnect. The amber "BYPASS" LED will be ON since there is no pressure in the tanks.
34. If the nitrogen generator is isolated from the sprinkler system:
  - The air compressor of the INS-2500 (AP) should take no longer than 10 minutes to pressurize the two tanks and turn off.
35. The amber "BYPASS" LED should turn off.
36. If the air compressor is not turning off or it is taking longer than expected, it could indicate a leak.
37. Allow the system to hold pressure for several minutes. Check all piping connections for leaks. Any drop in pressure on the nitrogen tank or air tank during this time could indicate a leak.
38. If there is a drop in pressure, soap all filters and blow-down strainer.

### **Air Compressor Replacement**

1. See Ingersoll Rand Air Compressor Manual #7348130000.

### **Nitrogen Membrane Replacement**

1. Isolate the nitrogen generator from the sprinkler system.
2. Disconnect power to the nitrogen generator using lockout-tagout procedure.
3. Relieve pressure from the nitrogen tank and the air compressor tank.
4. Using 2 wrenches, remove black hose by unscrewing the brass fitting at the Flow Control Valve (FCV01).
5. Using 2 wrenches, remove black hose by unscrewing the brass fitting near Membrane Inlet Air Solenoid (XV01).
6. Remove clamp bolts on the front of the nitrogen membrane and remove the nitrogen membrane from brackets.
7. Remove fittings from top and bottom of nitrogen membrane.
8. Install fittings into top and bottom of new nitrogen membrane.
9. Remove plastic cap from side port on the lower portion of the nitrogen membrane.
10. Check to ensure nitrogen membrane inlet and outlet ports are in the correct orientation, then place new nitrogen membrane into brackets.
11. Reinstall and tighten clamp bolts.
12. Reattach black hoses to their respective fittings.
13. Restore power to the nitrogen generator.
14. Retest nitrogen purity (adjustments may be necessary) .

## Maintenance Alerts and Actions

A maintenance alert is noncritical to the operation of the nitrogen generator. The maintenance light will turn on and a maintenance alert will appear on the IntelliGen™ Display and IntelliView™ website, and an e-mail will also be sent. The Trouble Horn will not sound and the BMS will not trip. Maintenance alerts can be cleared by performing maintenance on the issue then going into the "Maintenance Menu" and clearing the appropriate alert.

### Maintenance Alert #1 - Standard Maintenance

**Issue:** Maintenance Timer expired after 1,000 hours and the nitrogen generator needs maintenance.

**Action:**

1. Within 250 compressor operating hours, complete standard maintenance following the procedure in this manual.
2. Reset Maintenance Alert #1 by going into the Maintenance Menu on the display and following the procedure on page 28.

### Maintenance Alert #2 - Excess Nitrogen Demand (Sprinkler System Leak Rate Excessive)

**Issue:** Sprinkler system leak rate is greater than Leak Rate Warning Set Point. You have one week to address this before it turns into a trouble.

**Action:**

1. Leak check nitrogen generator and sprinkler system. Repair leaks if found.
2. Adjust Leak Rate Warning Set Point. See page 42 for details.  
*Note:* Increased leak rates can cause excessive maintenance and damage to equipment.
3. Reset the Maintenance Alert #2 by going into the Maintenance Menu on the display.

## Trouble Alerts and Probable Causes

A trouble alert is a critical alert to the operation of the nitrogen generator. The trouble light will turn on and a trouble alert will be created on the IntelliGen™ Display and IntelliView™ website, an e-mail will also be sent. The Trouble Horn will sound and the BMS will trip. Trouble alerts can be cleared by fixing the issue and pressing “CLEAR” on the display keypad, and entering passcode "0000".

### Trouble Alert #1 - Nitrogen Generator in Bypass Mode for 2 hours

**Issue:** Bypass Solenoid Valve continuously ON for 2 hours.

**Probable Cause:**

1. Air compressor power is turned off.
2. Air Tank Outlet Valve (V01) is closed.
3. Filling multiple sprinkler systems at one time.
4. Leak on nitrogen generator air tank or sprinkler system.
5. Blockage in pathway from air tank to nitrogen tank.
6. Low oil level (check oil level switch).

### Trouble Alert #2 - Air Compressor is Continuously Running

**Issue:** Air tank pressure switch continuously ON for 90 minutes.

**Probable Cause:**

1. Filling multiple sprinkler systems at one time.
2. Major leak on nitrogen generator (air side).
  - a. Air Tank Blow-Down (AD01) stuck open.
  - b. Float valve on filters stuck open.
3. Leak on sprinkler system.
4. Pressure switch needs to be adjusted or replaced.
5. Air compressor not building adequate pressure.
6. Compressor unloader valve located on pressure switch is stuck open.

### Trouble Alert #3 - Excessive Air Compressor Cycling

**Issue:** Air tank pressure switch turns ON 10 times in 1 hours.

**Probable Cause:**

1. Leak on nitrogen generator air tank. Check valve sticking open could cause the leak.
2. Float valve on filters could also be stuck open.
3. Excess Air Regulator (PRV01) closed.
4. Pressure switch needs to be adjusted or replaced.
5. Filter elements need to be replaced.
6. Membrane Inlet Air Solenoid (XV01) is stuck open.

### Trouble Alert #4 - Excessive Membrane Runtime

**Issue:** Membrane Inlet Air Solenoid (XV01) and Membrane Outlet N<sub>2</sub> Solenoid (XV02) continuously ON for 30 minutes.

**Probable Cause:**

1. Leak on nitrogen generator or sprinkler system.
2. Air Compressor Power is turned off.
3. Air Tank Outlet Valve (V01) closed.
4. Membrane Inlet Air Solenoid (XV01) and/or Membrane Outlet N<sub>2</sub> Solenoid (XV02) are blocked, or closed.
5. Instrument Air Regulator (PRV03) is less than 4,14 bar/414 kPa (60 psi).
6. Blockage in pathway from air tank to nitrogen tank.

### Trouble Alert #5 - Excessive Membrane Cycling

**Issue:** Nitrogen valves turn ON 24 times in 4 hours.

**Probable Cause:**

1. Leak on sprinkler system.
2. Leak on nitrogen tank.
3. Pressure settings need to be adjusted or pressure transducer replaced.
4. Membrane Outlet N<sub>2</sub> Solenoid (XV02) is stuck open.

### Trouble Alert #6 - Nitrogen Generator Cannot Keep Up While in Nitrogen Generating Mode

**Issue:** Bypass Solenoid cycles 16 times over 4 hours.

**Probable Cause:**

1. Filling multiple sprinkler systems.
2. Performing functionality testing on the nitrogen generator.
3. Leak on nitrogen generator or sprinkler system.

### Trouble Alert #7 - Excess Nitrogen Demand (Sprinkler System Leak Rate Excessive)

**Issue:** Sprinkler system leak rate is greater than Leak Rate Warning Set Point and has not been acknowledged for a week.

**Probable Cause:**

1. Leak on sprinkler system.
2. Leak on nitrogen tank.
3. Leak Rate Warning Set Point not appropriate for application.

### Trouble Alert #8 - Maximum Temperature Limit Exceeded

**Issue:** Temperature inside the cabinet has exceeded the maximum limit.

**Probable Cause:**

1. Check fan operation.
2. Check cabinet ventilation.

### Trouble Alert #9 - Maintenance

**Issue:** Compressor Maintenance Timer expires when maintenance request has not been reset in 250 hours.

**Probable Cause:**

1. Standard maintenance was not completed.
2. Maintenance timer not reset.

### Trouble Alert #10 - Hardware Failure Detected

**Issue:** IntelliGen™ Controller failure detected.

**Probable Cause:**

1. Short circuit on output wiring.

### Trouble Alert #11 - PLINK Connection Error

**Issue:** Devices cannot communicate.

**Probable Cause:**

1. Wiring not correct.
2. Power failure.

### Trouble Alert #12 - PLINK Device Trouble

**Issue:** One or more PLINK devices are reporting trouble.

**Probable Cause:**

1. An INS-PV connected to the generator has an error.
2. See INS-PV Manual #5401532.

## Troubleshooting

### Leak on Sprinkler System or Nitrogen Generator

1. View the Leak Rate (LR) by exiting to the main menu of the IntelliGen™ Display. It will be displayed as LR: # bar/24HR.
2. If the Leak Rate (LR) is greater than 0,41 BAR (41 kPa) (6 psi)/24HR; there is an excessive leak.
3. Isolate the nitrogen generator from the sprinkler system using the N<sub>2</sub> Tank Outlet Valve (V03).
4. Allow the nitrogen generator to fill the nitrogen and air tanks.
5. Once the air compressor turns off allow the nitrogen generator to sit for 30 minutes.
6. If pressure drops in the air tank or nitrogen tank that indicates there is a leak on the nitrogen generator.
7. Soap all fittings and tighten fittings that are leaking. Avoid electronics.
8. If pressure does not drop, this indicates the leak is outside of the nitrogen generator. Check all piping downstream of the N<sub>2</sub> Tank Outlet Valve (V03). Fix leaks as needed.
9. Clear the trouble using the “CLEAR” button on the IntelliGen™ Display and enter passcode "0000".

### Testing Nitrogen Flow Rate and Nitrogen Purity

1. Isolate the nitrogen generator from the sprinkler system using the N<sub>2</sub> Tank Outlet Valve (V03) on the nitrogen tank. Allow the nitrogen generator to fill the air tank and nitrogen tank.
2. When the nitrogen tank pressure reaches approximately 5,51 bar (551 kPa) (80 psi) the red instrument air solenoid lights located inside the cabinet should turn off.
3. To ensure the nitrogen generator is operating correctly and that the correct nitrogen purity is being produced a functional test must be performed.
4. On the inside of the nitrogen cabinet, locate the blue N<sub>2</sub> Bleed Valve (V04) near the Nitrogen Sample Port (SP).
5. Slightly open the blue N<sub>2</sub> Bleed Valve (V04) and begin draining the pressure out of the nitrogen tank.
6. Quickly close the blue N<sub>2</sub> Bleed Valve (V04) when you see the red instrument air solenoid lights turn on. This will happen at approximately 4,41 bar (441 kPa) (60 psi).
 

**Note:** If the pressure in the nitrogen tank drops below 3,79 bar (379 kPa) (55 psi) the nitrogen generator will return to Bypass Mode. Wait for the nitrogen generator to refill the tanks and the unit to return to Nitrogen Generating Mode before trying again.
7. Begin timing to see how long it takes to reach approximately 5,51 bar (55 kPa) (80 psi) in the nitrogen tank.
8. If the nitrogen generator is isolated from the sprinkler system, the INS-2500 (AP) should take no longer than 8 minutes to pressurize the nitrogen tank to 5,51 bar (55 kPa) (80 psi).
9. During this time, connect the Portable Nitrogen Analyzer to the Nitrogen Sample Port (SP) to measure the purity of the exiting gas. The analyzer should read 98.0% ± 1%. This may take a few minutes.
10. When the nitrogen generator reaches approximately 5,51 bar (55 kPa) (80 psi) in the nitrogen tank, the red instrument air solenoid lights will turn off. The air compressor will continue to run until the air tank pressure reaches approximately 10 bar (100 kPa) (145 psi).
11. Allow the nitrogen generator to sit for 30 minutes.
12. If pressure drops in either tank this indicates there is a leak in the nitrogen generator. Soap all pre-plumbed fittings and tighten any fittings that are leaking. Avoid electronics.
13. If the pressure does not drop, this indicates the leak is outside of the nitrogen generator. Check sprinkler system for leaks.

**Normal Operating Parameters of the INS-2500 (AP)**

The Potter IntelliGen™ Nitrogen Generators use a two tank system design to deliver high purity nitrogen to the fire protection system. The pressure switch on the air tank controls the air compressor by turning it on and off at the desired pressure set points. A pressure transducer on the nitrogen tank controls the pneumatic valves on the inside of the cabinet. Whenever the nitrogen tank requires nitrogen, the pneumatic valves open allowing air to flow from the air tank. When the nitrogen tank reaches the desired set point the pneumatic valves close.

- Periodic running of the air compressor is expected (typically less than 24 times a day).

	<b>INS-2500 (AP)</b>	<b>Recorded Parameter</b>
Air Compressor OFF Pressure*	10 bar (100 kPa) (145 psi)	
Air Compressor ON Pressure*	8 bar (800 kPa) (116 psi)	
Nitrogen Tank OFF Pressure*	5,51 bar (55 kPa) (80 psi)	
Nitrogen Tank ON Pressure*	4,14 bar (414 kPa) (60 psi)	
Max time interval to build pressure from 4,14 bar (414 kPa) (60 psi) to 5,51 bar (55 kPa) (80 psi) in nitrogen tank in Nitrogen Generating Mode	8 minutes	

\* Pressures are approximated and can vary ±0,21 bar (21 kPa) (3 psi).

## Nitrogen Generator Leak Detection System

Each Potter IntelliGen™ Nitrogen Generator comes with an integrated Leak Detection System. The Leak Detection System uses pressure decays to calculate the actual pressure loss in 24 hours, or the Leak Rate of the sprinkler system.

This Leak Rate is displayed on the IntelliGen™ Display as “LR # BAR/24HR”. # is the pressure in bar that is calculated.

Increases in the Leak Rate can cause excessive demand on the nitrogen generator. Excessive demand causes increased runtimes on the unit. Increased runtimes increase the frequency of maintenance and repairs. In some cases, excessive Leak Rates can cause catastrophic failures.

The Leak Detection System is designed as a rolling average over 1 week to ensure the presence of an actual leak. To reset the LR number, reset the Maintenance Alert #2 under maintenance on the IntelliGen™ display.

All Potter IntelliGen™ Nitrogen Systems are designed to run approximately 1,000 operating hours in a typical year.

This translates to a maximum pressure loss of 0,41 (41 kPa) (6) in 24 hours. This is the default Leak Rate Warning Set Point. If the actual Leak Rate of the sprinkler system is greater than that value, a maintenance alert or a trouble will display on the nitrogen generator.

The Leak Rate Warning Set Point in the Potter IntelliGen™ Nitrogen Generator is a user adjustable set point for when a maintenance or trouble alert is activated. It will give a preemptive warning that the system Leak Rates have increased above the acceptable level.

This Leak Rate Warning Set Point can be set from 0,069 bar (6,9 kPa) (1 psi) up to 2,48 bar (248 kPa) (36 psi) per 24 hours.

- NFPA 13 allows a leak rate of 0,103 bar (10,3 kPa) (1.5 psi) loss per 24 hours for new systems.
- NFPA 25 allows a leak rate of 0,21 bar (20.7 kPa) (3 psi) loss per 2 hours for existing systems.

### WARNING

Increases in Leak Rates will cause more maintenance and possible failures.

Example: At a 0,41 bar (41 kPa) (6 psi) loss per 24 hour leak rate, the unit will run approximately 1,000 hours per year. At a 2,48 bar (248 kPa) (36 psi) loss per 24 hour leak rate, the unit will run approximately 6,000 hours per year. That means, at a 0,41 bar (41 kPa) (6 psi) leak rate, the air compressor will be operating 11% of the year, compared to a 2,48 bar (248 kPa) (36 psi) leak rate, where the air compressor will be operating 70% of the year.

### To Change the Leak Rate Warning Set Point:

1. Press "Enter" on the IntelliGen™ Display keypad.
2. Select "Settings" using the keypad.
3. Enter passcode "0000".
4. Select "Leak Rate". Press "ENTER".
5. Press "ENTER" to choose settings.
6. Select "Leak Rate Warning". Press "ENTER".
7. Using the directional arrows, adjust the leak rate limit number "--" bar per 24 hours.
  - a. NFPA allows 1,03 bar (103 kPa) (1.5 psi) per 24 hours on new systems.
  - b. Potter Nitrogen Generators are designed of 0,41 bar (41 kPa) (6 psi) per 24 hours.
8. Press "ENTER" to confirm.
9. Press "ENTER" to acknowledge warning.
10. Press "ENTER" to accept change.
11. Press "ESC" until returned to main menu.

The Leak Rate is also calculated based on the size of the sprinkler system the nitrogen generator is protecting. The INS-2500 (AP) is factory set at 24,000 gallons (max). This can be adjusted lower if the units are servicing smaller systems.

### To Change the Sprinkler System Size:

1. Press "ENTER" on the IntelliGen™ Display keypad.
2. Select "Settings" using the keypad. Press "ENTER".
3. Enter passcode "0000".
4. Select "Leak Rate". Press "ENTER".
5. Press "Enter" to choose settings.
6. Select "Sprinkler Capacity". Press "ENTER".
7. Using the numeric pad, enter the total system volume size in gallons.
8. Press "ENTER".
9. Press "ESC" to return to main menu.

### INS-2500 (AP) Cabinet Dimensional Drawings

Fig. 48

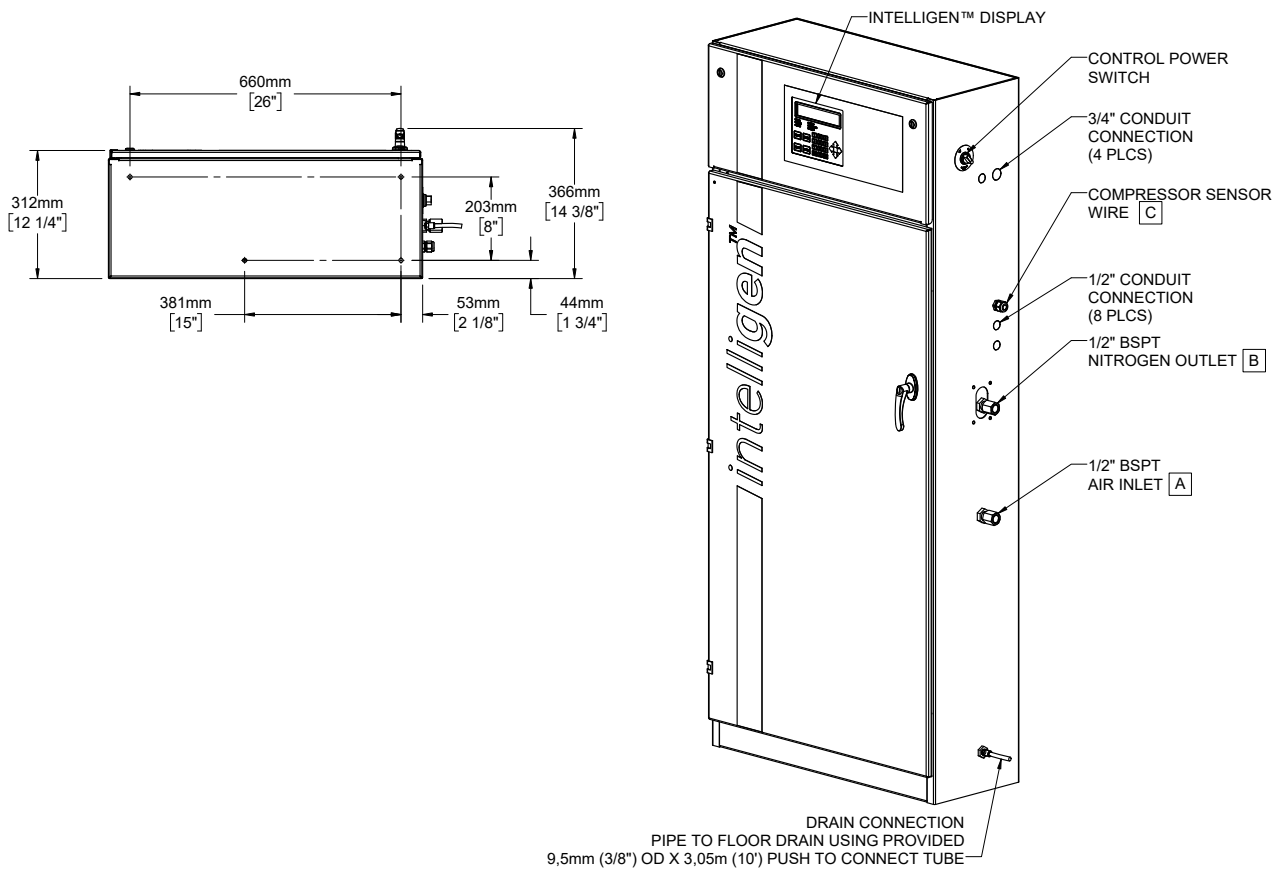
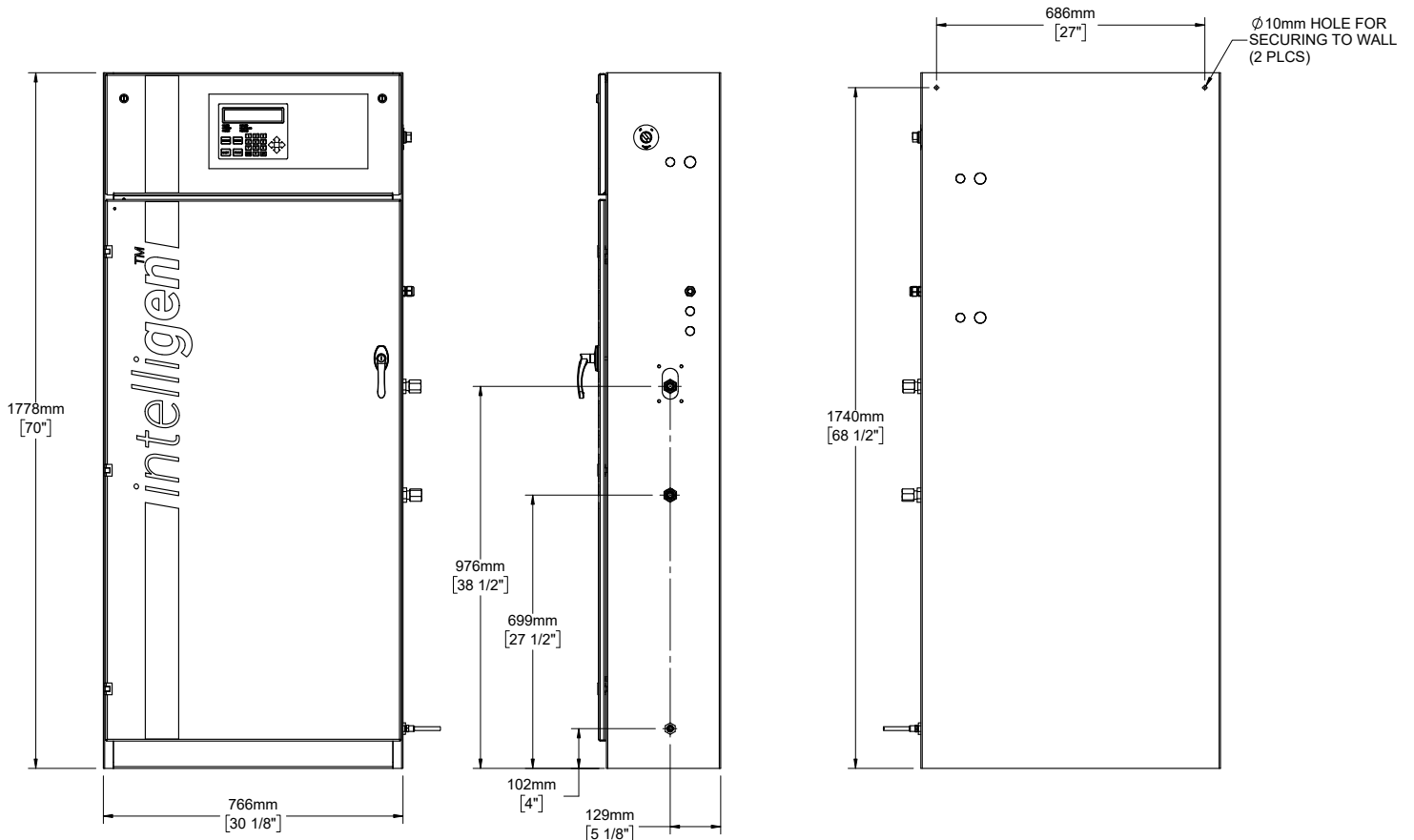

**INS-2500 (AP) Nitrogen Tank Dimensional Drawings**

Fig. 49

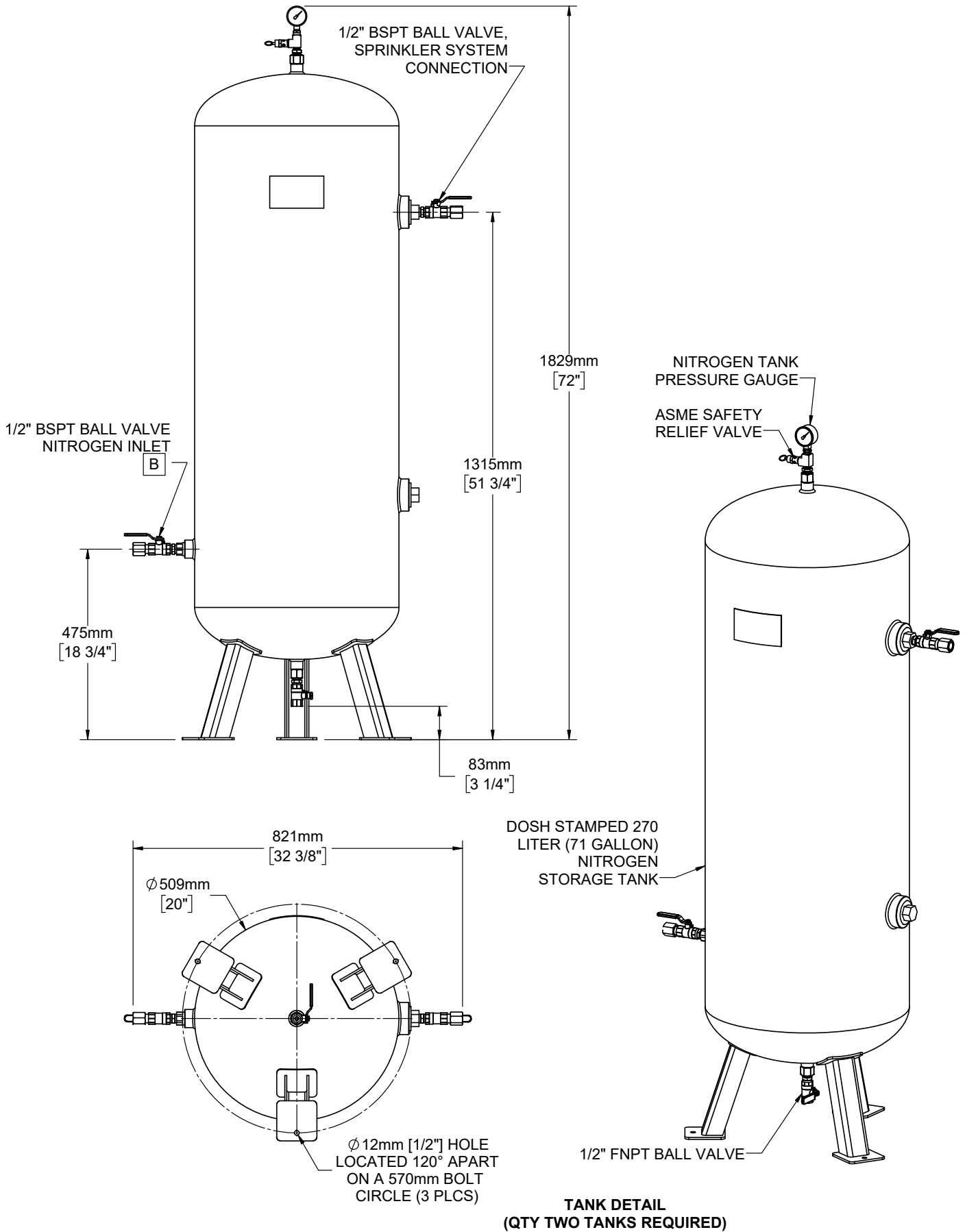

**INS-2500 (AP) Compressor Dimensional Drawings**

Fig. 50

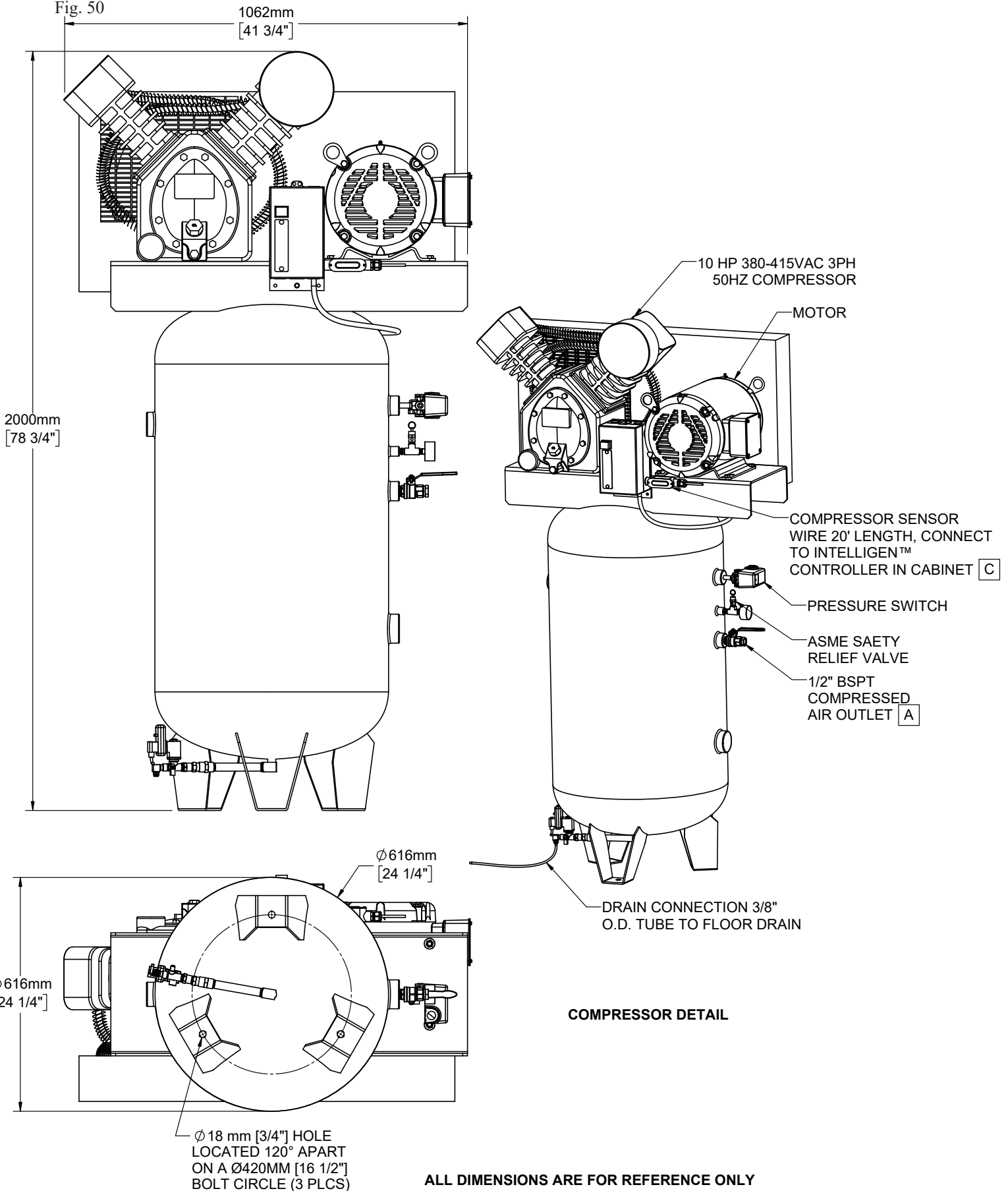

INS-2500 (EU/AP) PIPING INSTRUMENTATION DIAGRAM

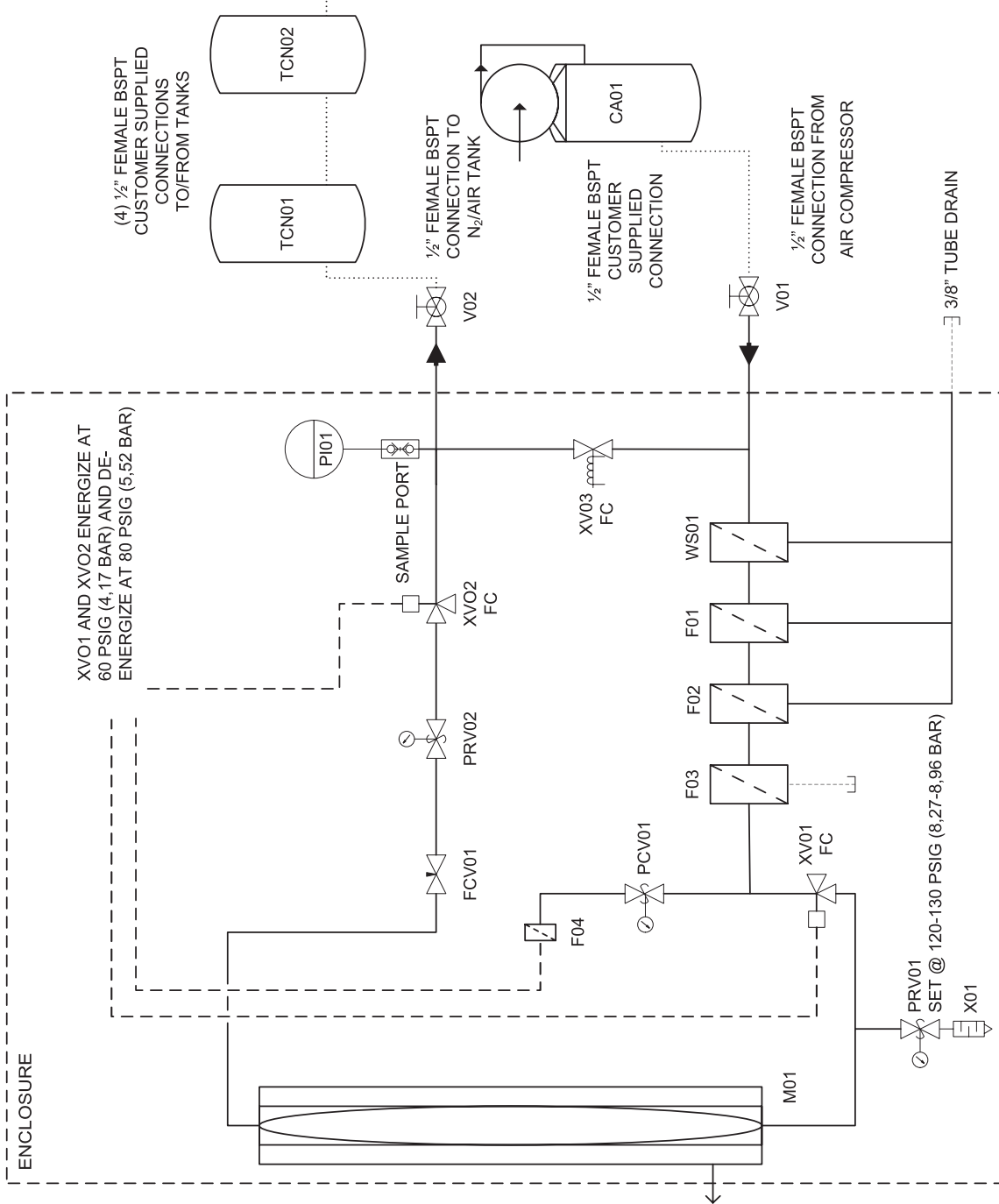

ITEM	DESCRIPTION
CA01	AIR COMPRESSOR
WS01	WATER SEPARATOR
F01	COALESCING FILTER 1 µm
F02	COALESCING FILTER .01 µm
F03	CARBON ABSORBER
F04	INSTRUMENT AIR FILTER
FCV01	FLOW CONTROL VALVE
M01	NITROGEN MEMBRANE
PCV01	INSTRUMENT AIR REG.
PI01	PRESSURE TRANSDUCER
PRV01	EXCESS AIR REG.
PRV02	BACK PRESSURE REG.
TCN01	TANK-COMPRESSED N <sub>2</sub>
TCN02	TANK-COMPRESSED N <sub>2</sub>
V01	1/2" BALL VALVE
V02	1/2" BALL VALVE
X01	EXCESS AIR SILENCER
XV01	INLET AIR
XV02	N <sub>2</sub> DISCHARGE
XV03	BYPASS VALVE

INS-1500/2000/2500 380-415VAC 3PH 50HZ WIRING DIAGRAM

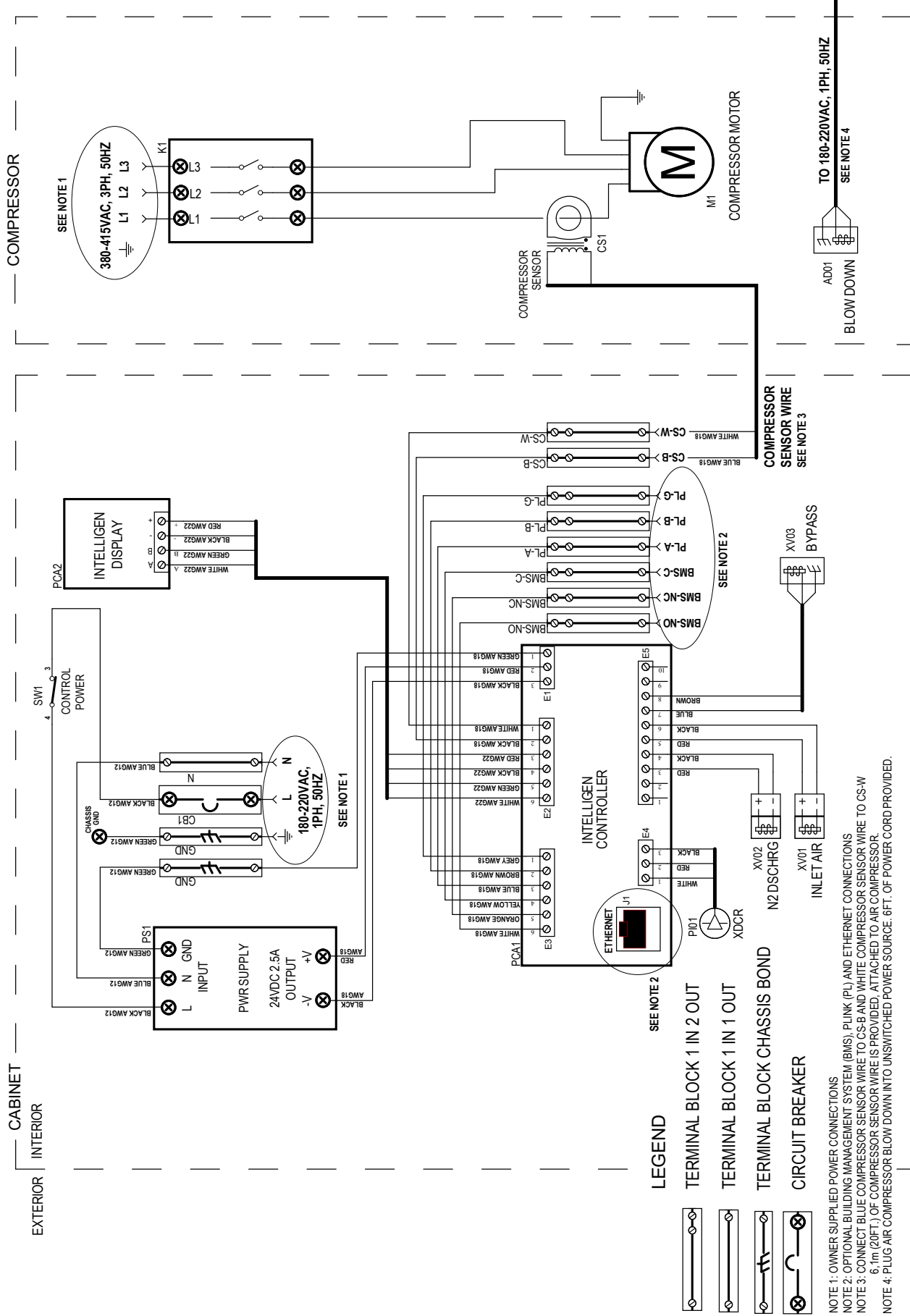

- LEGEND**
- TERMINAL BLOCK 1 IN 2 OUT
  - TERMINAL BLOCK 1 IN 1 OUT
  - TERMINAL BLOCK CHASSIS BOND
  - CIRCUIT BREAKER

NOTE 1: OWNER SUPPLIED POWER CONNECTIONS  
 NOTE 2: OPTIONAL BUILDING MANAGEMENT SYSTEM (BMS), PLINK (PL) AND ETHERNET CONNECTIONS  
 NOTE 3: CONNECT BLUE COMPRESSOR SENSOR WIRE TO CS-B AND WHITE COMPRESSOR SENSOR WIRE TO CS-W  
 NOTE 4: PLUG AIR COMPRESSOR BLOW DOWN INTO UNSWITCHED POWER SOURCE. 6FT. OF POWER CORD PROVIDED.

## Menu Trees

### 1. Menu Tree 1

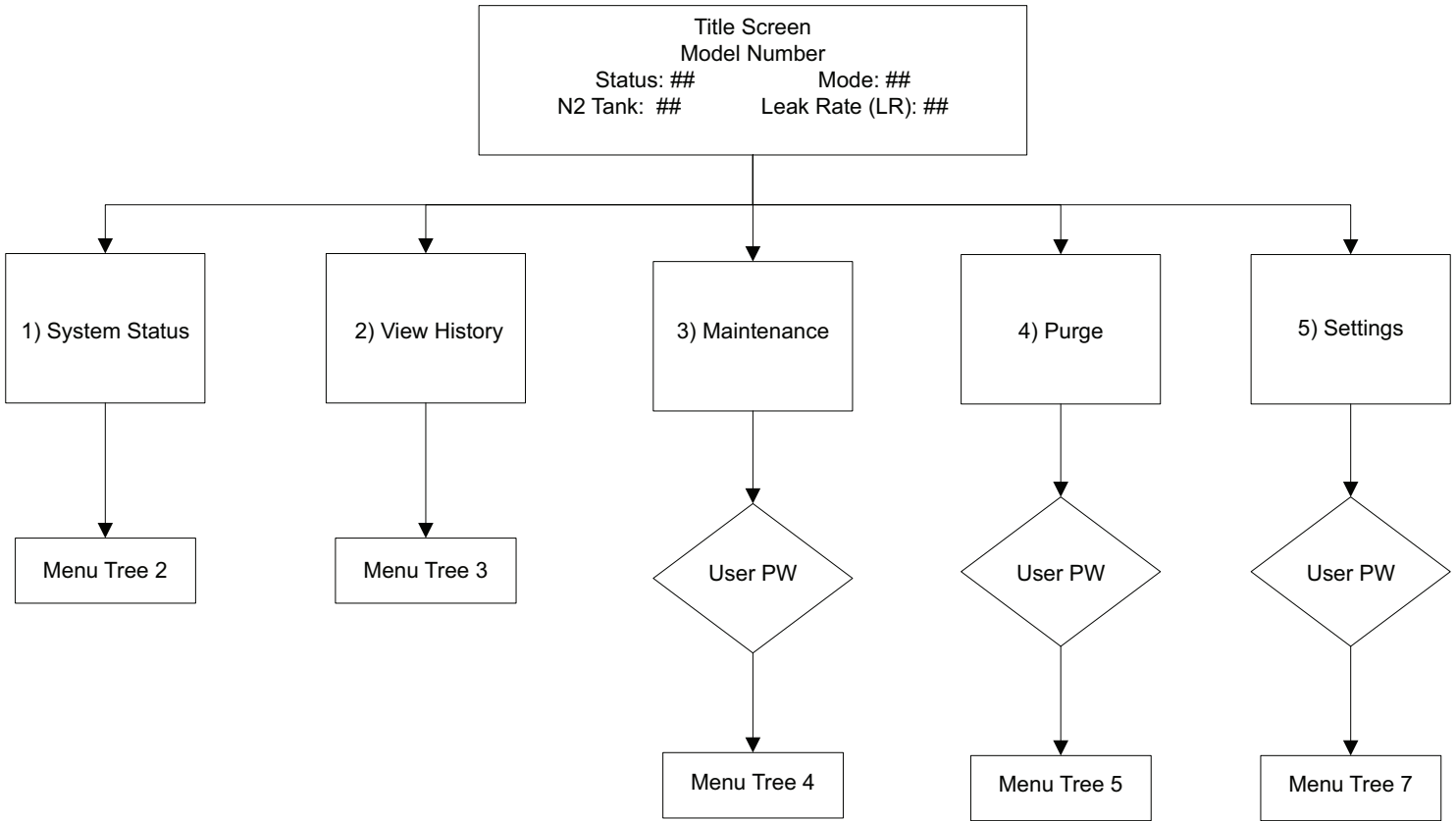

2. Menu Tree 2

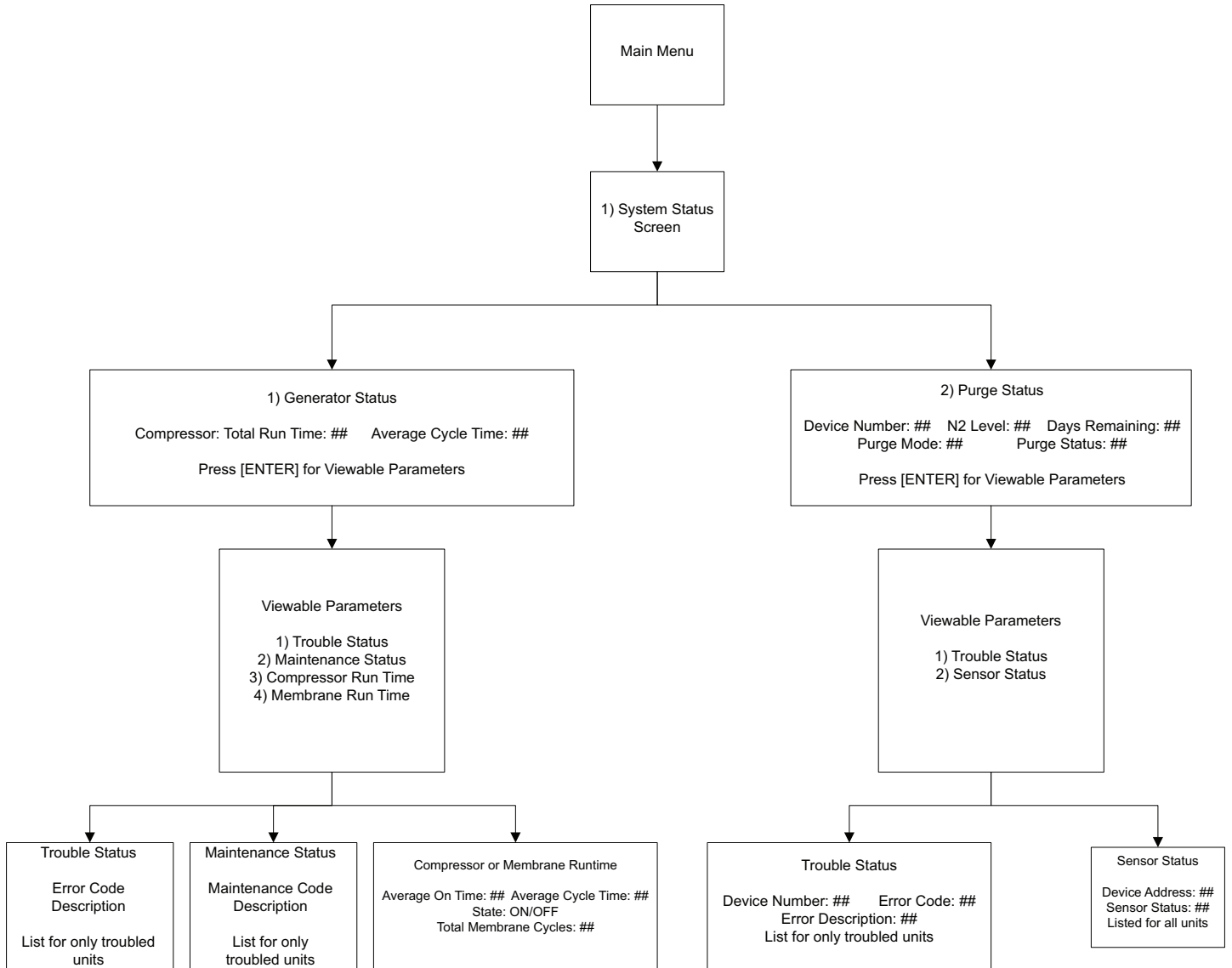

### 3. Menu Tree 3

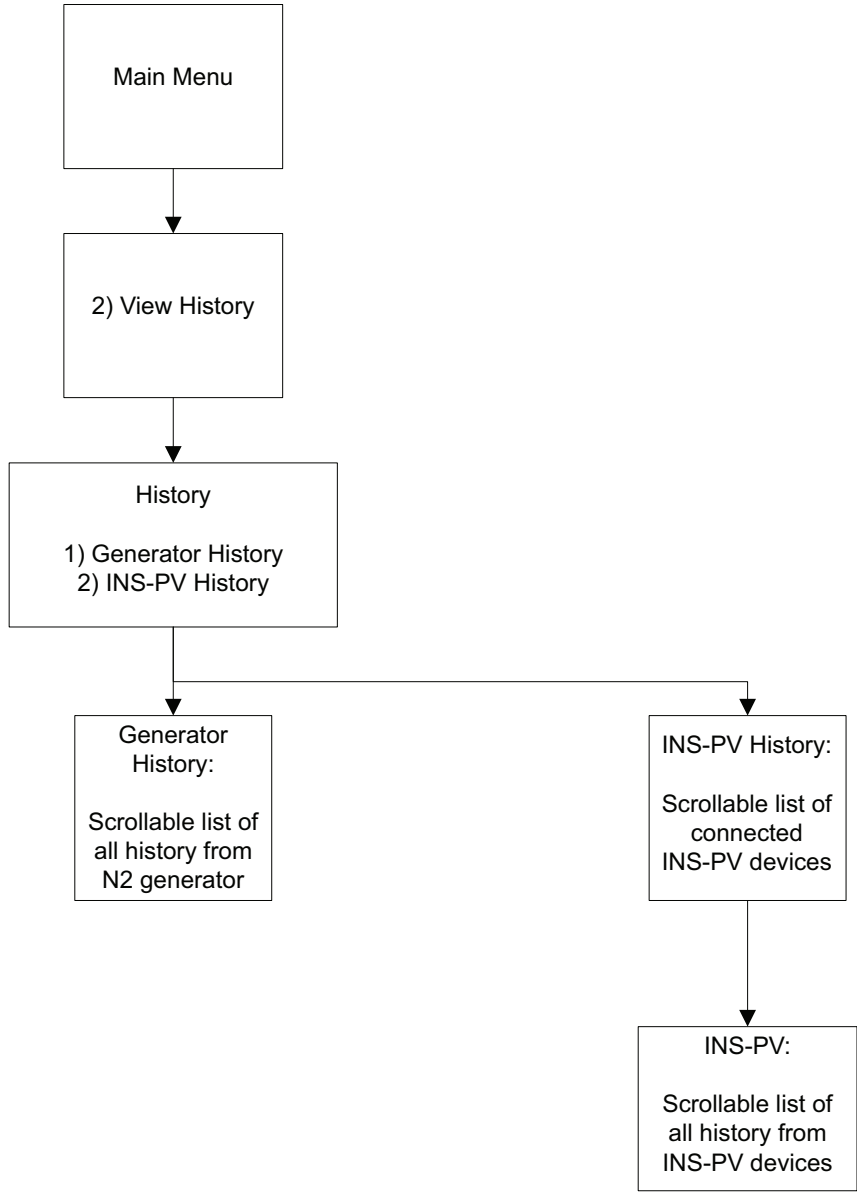

4. Menu Tree 4

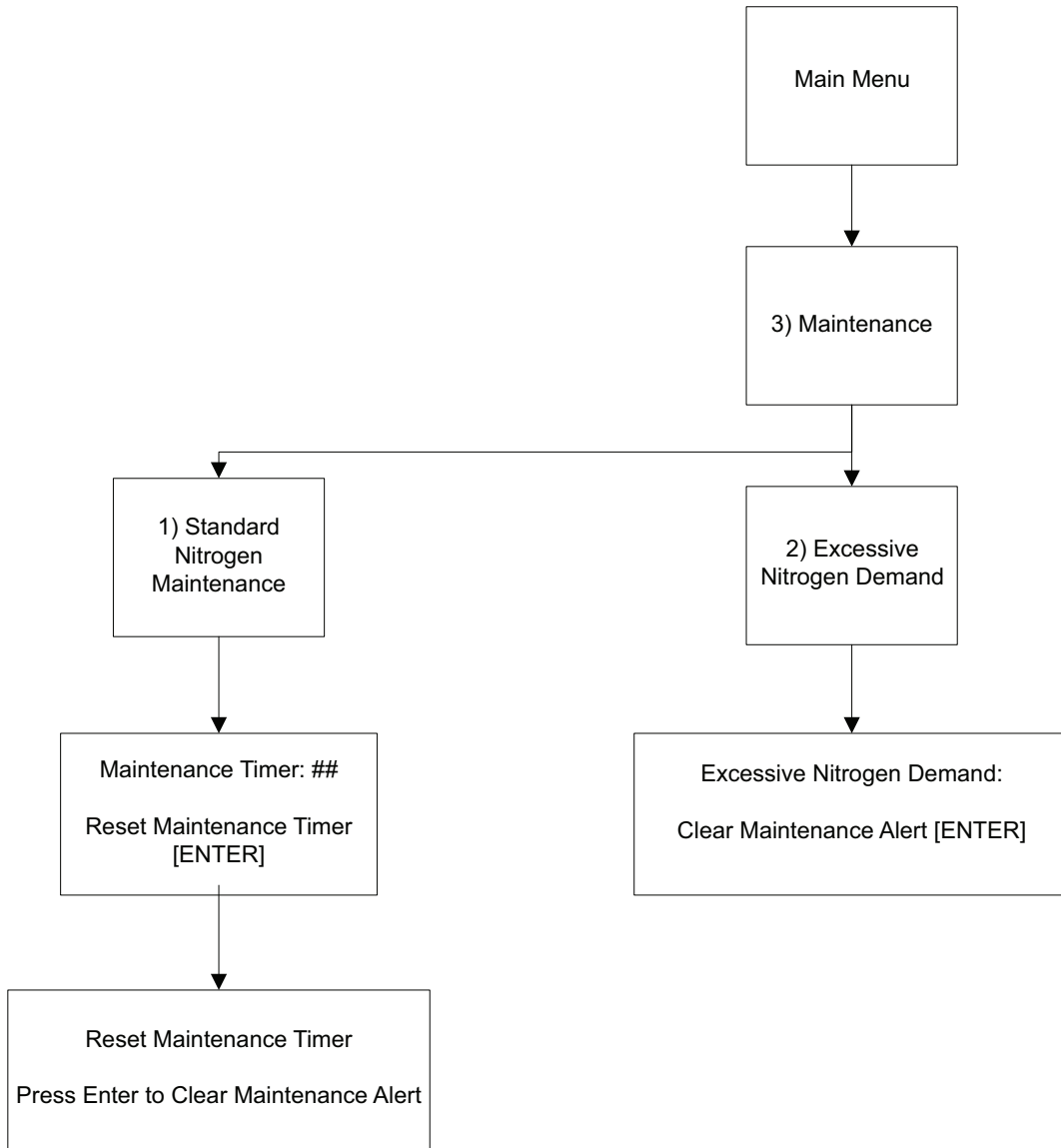

5. Menu Tree 5

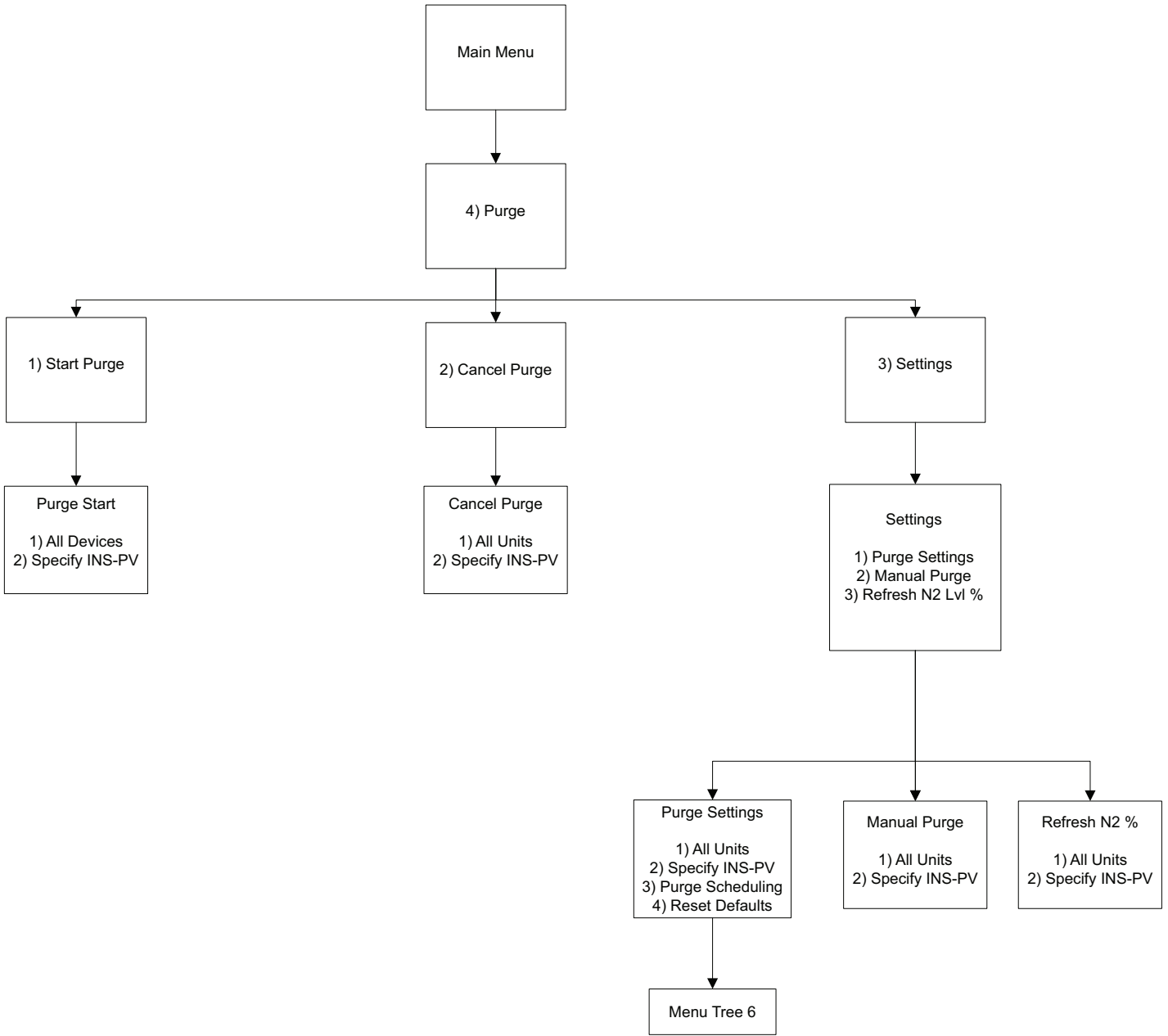

6. Menu Tree 6

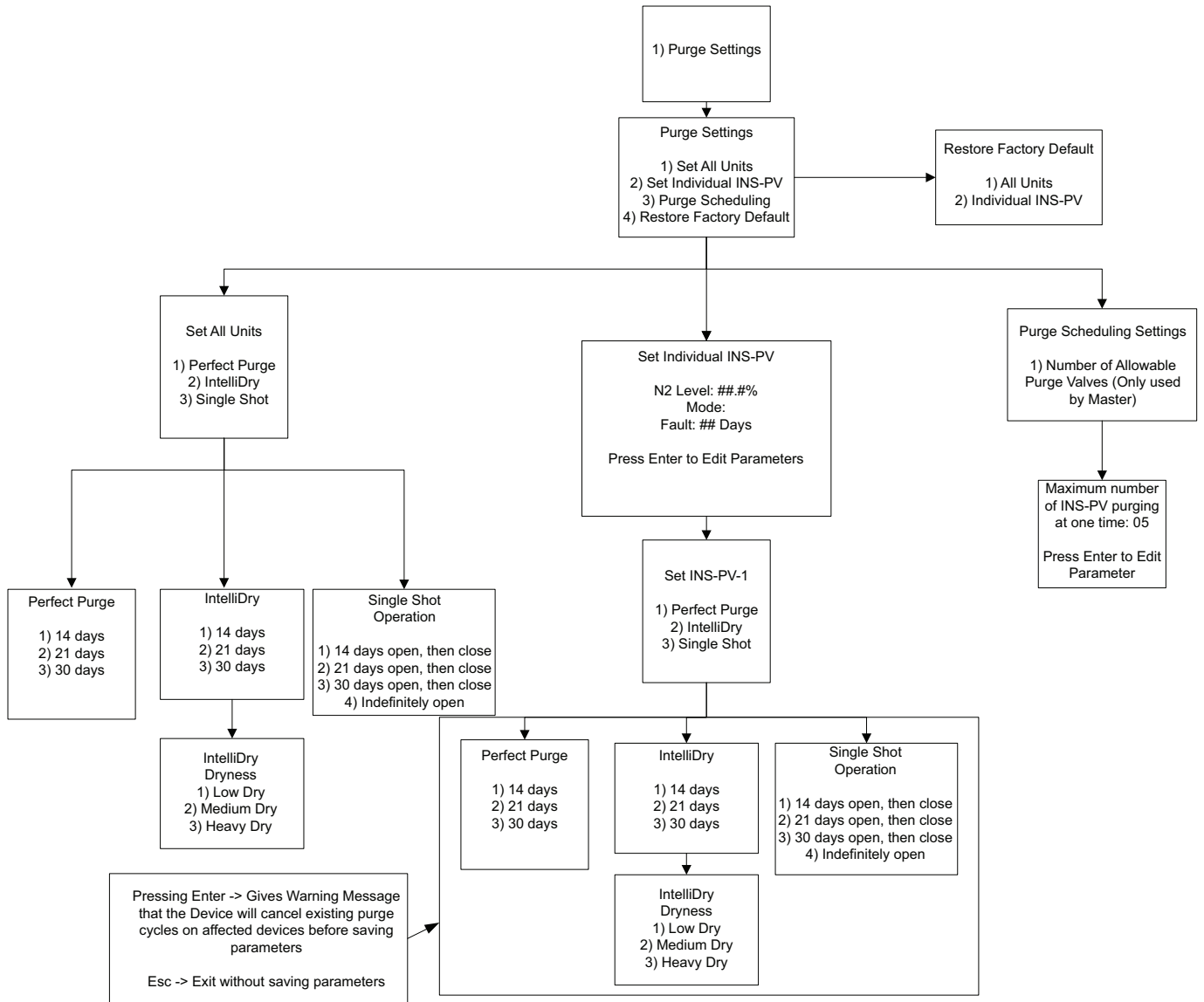

7. Menu Tree 7

