

- 9.5.4 The CO-12/24 alarms do not include power supervision. This may be accomplished by installing a power supervision relay at the end of the alarm power circuit (see Figure 6 below). There is no internal backup battery.
- 9.6 After installing the mounting plate, place the alarm on the mounting plate. Twist the alarm in the direction indicated by the "ON" arrow on the alarm cover until it locks in place.
- 9.7 To make your carbon monoxide alarm tamper resistant, a locking pin has been provided in the bag with the screws and anchors. Using this pin will deter children and others from removing the alarm from the mounting plate. To use the pin insert it into the hole in the side of the alarm after the alarm has been installed on the mounting plate (see Figure 7). To remove the alarm, use long nose pliers pull the pin out of the hole; it is now possible to remove the alarm from the mounting plate. Test alarm immediately following installation and weekly for proper operation by pushing the test button until a short beep is heard (approximately three seconds). Release the button. The alarm will then test itself for proper operation and the RED LED will flash 4-6 times. At completion of the self-test, the alarm will sound 2 alarm patterns. The alarm then resumes normal operation.
- 9.8 This box contains two self-adhesive labels. You should write the telephone numbers of the emergency service provider and a qualified technician in the space provided on the labels. Place one label next to the alarm, and the other label near a source of fresh air where you plan to gather after the alarm indicates the presence of carbon monoxide.
- 9.9 Attention Installer: Please leave this manual at residence for user's information

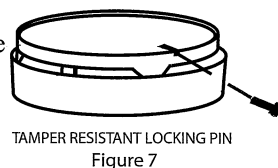

TAMPER RESISTANT LOCKING PIN
Figure 7

10.0 ALARM SIGNALS

10.1 NORMAL OPERATION

RED L.E.D. flashes once every 30 seconds, indicating that the alarm is powered and active.

10.2 ALARM CONDITION

RED LED turns "on" for 2 seconds and "off" for 4 seconds with 4 short beeps for 1 second and 5 seconds of silence. The RED LED will illuminate and the alarm relay will be energized (N.O. or N.C.). Pushing and holding the test/reset button for 3 seconds will silence the alarm for about 4 minutes. After 4 minutes, the alarm will once again sound until the unsafe CO concentration is reduced.

10.2.1 Connected zone should be programmed for 24 hour monitoring and immediate response for hazardous levels of carbon monoxide.

10.2.2 Alarm RELAY output 1 form 'C' dry contacts (non-latching) current capacity is 0.1A-30Vdc

10.3 TROUBLE CONDITION

The detector self-tests every 10 minutes. The detector will beep and the Indicator/Test button will flash twice every 30 seconds if a fault is detected. This is an indication of a malfunction and that the detector requires immediate servicing.

10.3.1 Trouble RELAY output

1 form 'C' dry contacts (non-latching) current capacity is 0.1A-30Vdc Trouble relay connection to panel is optional.

11.0 MAINTENANCE

CLEANING YOUR ALARM:

- 11.1 Keep your CO alarms clean—do not wash.
- 11.2 To clean your alarm first remove the tamper resistant locking pin (section 9.7), then remove the alarm from the mounting bracket as outlined in section 9.2.
- 11.3 You can clean the interior of your alarm by using your vacuum cleaner hose and vacuuming through the openings around the perimeter of the alarm.
- 11.4 The outside can be wiped with a cloth.
- 11.5 After cleaning, reinstall your alarm and test your alarm by using the TEST button.
- 11.6 Test your alarms weekly and repair or replace them when they no longer function. As with any electronic product, alarms have a limited life and alarms that do not work cannot warn you.

WARNING: Do not use any household cleaning agents, paints, varnishes or any other chemical on your CO-12/24 alarm.

NOTE: REGULAR TESTING IS RECOMMENDED.

12.0 PERIODIC ALARM TESTING

Test the alarm weekly for proper operation by pushing the test button until a short beep is heard (approximately three seconds). Release the button. The alarm will then test itself for proper operation and the RED LED light will flash 4-6 times. At completion of the test, the alarm will sound 2 patterns. The alarm then resumes normal operation.

IMPORTANT: If your security system is monitored by a central station, they must be notified before the system is tested.

13.0 SERVICE AND WARRANTY

If after reviewing this manual you feel that your CO Alarm is defective in any way, do not tamper with the unit. Before returning the device, call Potter's customer service line at 1-800-325-3936 to receive a return merchandise authorization (RMA) number. Once an RMA number has been issued, return the product along with a note describing the problem and send it to:

Potter Electric Signal Company LLC 2081 Craig Road
St. Louis, MO 63146-4161

LIMITED WARRANTY

POTTER Model CO-12/24
The Symbol of Protection

Potter Electric Signal Company LLC offers you this limited warranty on your new carbon monoxide alarm, including all of its component parts. This limited warranty extends solely to the original end-user purchaser of this product, provided your purchase was made from an authorized vendor. Transfer or resale of this product will automatically terminate warranty coverage.

Potter Electric Signal Company LLC warrants the enclosed carbon monoxide alarm be free from defects in materials and workmanship under authorized use and service, as specified in the owner's manual, for a period of six (6) years from the date of manufacture. During the initial two (2) year period commencing with the date of manufacture, any repair or replacement shall be made without charge. During the latter four (4) years of the warranty period, any repair or replacement shall be made at a charge to the purchaser not to exceed the manufacturer's cost of repair or replacement. All replaced items become the property of Potter Electric Signal Company LLC

POTTER ELECTRIC SIGNAL COMPANY LLC MAKES NO OTHER WARRANTIES, EXPRESS OR IMPLIED, EXCEPT AS REQUIRED BY LAW, AND IN NO CASE FOR A DURATION LONGER THAN THAT OF THIS WRITTEN WARRANTY, EXCEPT AS REQUIRED BY LAW, INCLUDING, BUT NOT LIMITED TO, ANY WARRANTY OF MERCHANTABILITY OR FITNESS FOR A PARTICULAR PURPOSE OR AGAINST INFRINGEMENT, OR ANY EXPRESS OR IMPLIED WARRANTY ARISING OUT OF TRADE USAGE OR OUT OF A COURSE OF DEALING OR COURSE OF PERFORMANCE.

Potter Electric Signal Company LLC has not authorized any other party to extend any other warranties in connection with the sale of the product, and will not accept responsibility for any statements, representations, or warranties made by any other person.

This limited warranty does not cover: (1) 9 volt alkaline battery (when applicable); (2) products which have been improperly installed, repaired, maintained, modified, or which have been subjected to misuse, abuse, accident, neglect, exposure to fire, water, or excessive changes in climate or temperature, or combined with non-Potter Electric Signal Company LLC approved accessories; (3) physical damage caused from use other than normal and proper operation or handling, as specified in the owner's manual; (4) cosmetic damage; (5) products on which warranty stickers or product serial numbers have been removed, altered, or rendered illegible; (6) the cost of installation, removal or reinstallation.

POTTER ELECTRIC SIGNAL COMPANY LLC SPECIFICALLY DISCLAIMS LIABILITY FOR ANY AND ALL DIRECT, INDIRECT, SPECIAL, GENERAL, INCIDENTAL, OR CONSEQUENTIAL DAMAGES, INCLUDING, BUT NOT LIMITED TO, LOSS OF PROFITS OR ANTICIPATED PROFITS ARISING OUT OF USE OF OR INABILITY TO USE THE PRODUCT.

POTTER
The Symbol of Protection

OWNER'S MANUAL

Model CO-12/24

Carbon Monoxide Gas Alarm

12-24Vdc System

PLEASE READ AND SAVE

Dear New POTTER® CO-12/24 Owner,

Congratulations as you have taken steps to help insure the health and life safety of you and your family. We are proud to offer you our unique, patented CO Sensor technology that detects CO in a manner similar to the human body's response. The POTTER® CO-12/24 is an ideal and low-cost way of warning you of both the acute and chronic effects of CO poisoning.

Please read this owner's manual carefully so you will have a better understanding of the effects of CO poisoning and the POTTER® CO-12/24 Alarm, as we work together pursuing a safer, healthier indoor air quality for us all. To your good health and safety,

Bernie Lears
President/CEO

Potter Electrical Signal Company LLC



WARNING: Failure to replace this product by the "REPLACE BY DATE" printed on the alarm cover may result in death by Carbon Monoxide poisoning. Replace By Date is six (6) years from date of manufacture.

1.0 GENERAL DESCRIPTION

This CO alarm is suited for residences, motels, hotels, and commercial or industrial system applications. The CO-12/24 is designed for 4-6 wire connection to 12 or 24VDC alarm system control panels. Reference: UL Listed Household Fire and/or Burglary Panel with auxiliary signaling zones. Connect to signaling zones which can be designated for CO alarm use only.

2.0 PRODUCT DATA

- 2.1 Sensitivity Setting: Unit will alarm at 150 ppm CO within 50 minutes.
- 2.2 Power: 12 or 24VDC nominal, operating voltage range 10-28 Vdc
- 2.3 Current Draw: Standby 60 microAmp. Trouble or Alarm 25 mA, 80mA maximum.
- 2.4 Field Wiring: 14-22 AWG
- 2.5 Alarm and Trouble Signal Relays Non-Latching
Contact ratings: Form "C", 0.1A - 30Vdc
- 2.6 Operating Temperature: 4.4° C - 37.8° C (40° F - 100° F)
- 2.7 Operating Humidity: 7.5-95%RH
- 2.8 Horn (Sounder) Loudness: 85 db @ 10 ft (3.3 meters)

SIGNALING



3.0 APPROVALS

Listed by Underwriters Laboratories Inc. to the Category Gas and Vapor Detectors and Sensors (FTAM). UL Standard 2075

4.0 WHAT YOU SHOULD KNOW ABOUT CO

Carbon monoxide (CO) is an insidious poison. It is a colorless, odorless and tasteless gas. It is a cumulative poison. Even low levels of CO have been shown to cause brain and other vital organ damage in unborn infants with no effect on the mother. The following symptoms are related to CARBON MONOXIDE POISONING and should be discussed with ALL members of the household:

MILD EXPOSURE

Slight headache, nausea, vomiting, fatigue (often described as "flu-like" symptoms)

MEDIUM EXPOSURE

Severe throbbing headache, drowsiness, confusion, fast heart rate

EXTREME EXPOSURE

Unconsciousness, convulsions, cardio respiratory failure, death

Many cases of reported CARBON MONOXIDE POISONING indicate that while victims are aware they are not well, they become so disoriented they are unable to save themselves by either exiting the building or calling for assistance. Also, young children and household pets may be the first affected.

Your CO alarm is designed to detect the toxic CO gas that result from incomplete combustion, such as those emitted from appliances, furnaces, fireplaces and auto exhaust.

A CO Alarm is NOT A SUBSTITUTE for other combustible gas, fire or smoke alarms. This carbon monoxide alarm is designed to detect carbon monoxide gas from ANY source of combustion.

CAUTION: This alarm will only indicate the presence of carbon monoxide gas at the sensor. Carbon monoxide gas may be present in other areas.

WARNING: This product is intended for use in ordinary indoor locations of family living units. It is not designed to comply with Occupational Safety and Health Administration (OSHA) commercial or industrial standards. Individuals with medical problems may consider using warning devices that provide audible and visual signals for carbon monoxide concentrations under 30 ppm.

5.0 WHAT YOU SHOULD DO IF THE ALARM SOUNDS



WARNING: Activation of this device indicates the presence of carbon monoxide (CO), which can KILL YOU. If alarm sounds:

- 1) Operate reset/silence button;
- 2) Call your emergency services () [fire department or 911];
- 3) Immediately move to fresh air - outdoors or by an open door/window. Then, do a head count to check that all persons are accounted for. Do not reenter the premises nor move away from the open door/window until the emergency services responders have arrived, the premises have been aired out, and your alarm remains in its normal condition.
- 4) After following steps 1-3, if your alarm reactivates within a 24-hour period, repeat steps 1-3 and call a qualified technician () to investigate for sources of CO from fuel burning equipment and appliances, and inspect for proper operation of this equipment. If problems are identified during this inspection, have the equipment serviced immediately. Note any combustion equipment not inspected by the technician and consult the manufacturers' instructions or contact the manufacturers directly for more information about CO safety and this equipment. Make sure that motor vehicles are not and have not been operating in an attached garage or adjacent to the residence.

5.1 IMPORTANT CONSIDERATIONS The CO-12/24 has been designed and is warranted to operate for six years.

5.2 The alarm will automatically sense when the level of CO in the air falls below the danger level. You should stay outside the residence in fresh air until the alarm is silenced. When the alarm sounds, do not stand too close to the alarm. The sound produced by the alarm is loud because it is designed to awaken a person in an emergency. Prolonged exposure to the alarm at a close distance may be harmful to your hearing.

6.0 DEVELOPING YOUR OWN CO SAFETY PLAN

This CO alarm can quickly alert you to the presence of CO but it cannot prevent toxic CO emissions. Please note that there are hazards against which CO detection may not be effective, such as gas leaks or explosions. The ultimate responsibility for protection against toxic CO gas rests solely on you. Installing CO alarms is just the first step in protecting your family from toxic CO poisoning. We also suggest that you create an effective, comprehensive safety program as outlined below.

6.1 Install CO alarms properly following the instructions in this manual

6.2 Develop a family escape plan and practice it with your entire family, especially small children.

- Draw a floor plan of your home/ residence and find two ways to exit from each room. There should be one way to get out of each bedroom without opening the door.

- Make sure that all occupants know what the CO alarm signal means and how they must be prepared to leave the residence by themselves if necessary.

- Decide on a meeting place a safe distance from your house and make sure all occupants understand where they should go and wait if there is a dangerous CO condition.

- Conduct CO safety drills at least every 6 months to make sure that every one, even small children, know what to do in order to escape safely.

- Know where to go to call the Fire Department from outside your residence.

7.0 IMPORTANT: WHAT YOUR CO ALARM CAN AND CANNOT DO

This unit is designed to detect carbon monoxide (CO) entering its sensing chamber. It does not sense combustible gas (such as natural gas, propane or butane), heat, smoke or flames.

When properly located, installed, and maintained, this CO alarm is designed to provide early warning of developing poisonous CO conditions at a reasonable cost. This alarm monitors the air, and when it senses CO, it activates its built-in alarm. It can provide precious time for you and your family to escape from your residence before CO can seriously injure or kill. However, such an early warning is possible only if the alarm is located, installed, and maintained as specified in the Owner's Manual.

WARNING: The POTTER® Model CO-12/24 CO Alarm is not designed for marine, RV, or aeronautical use.

NOTE: This unit contains no batteries and will not operate without power.

8.0 INSTALLING THE POTTER® CO-12/24 FOR RESIDENTIAL USE

8.1 RECOMMENDATIONS

One of the most important considerations in any CO alarm system is the location of the alarms. Statistics of the National Fire Protection Association (NFPA) show that most of the fatal CO occurrences happen at night while people are sleeping. Early warning of CO is best achieved by the correct installation of CO alarms. Placement of an alarm in a garage may cause an alarm due to CO from automotive exhaust.

If bedroom doors are usually closed at night, alarms should be placed in each bedroom as well as in the common hallway between them. CO alarms may not sense CO on a different level of a residence or building. For example, a second floor alarm may not sense a CO leak on the first floor or in the basement.

Therefore, alarms should be placed on every level of a residence or building. If the alarm is located outside of a bedroom, it may not wake up a sound sleeper, especially if the bedroom door is closed or only partly open. If the alarm is located on a different level of the residence than the bedrooms, it is even less likely to wake up people sleeping in the bedroom. Installing CO alarms may qualify you for lower homeowner's insurance rates, but CO alarms are not a substitute for insurance. Homeowners and renters should continue to insure their lives and property.

8.2 RECOMMENDED MOUNTING LOCATIONS

Put a CO alarm inside each bedroom where the occupant closes the door while sleeping. A closed door can block particulate smoke, but CO gas is likely to get through.

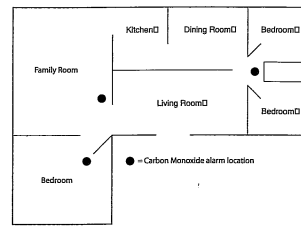

Figure 1: Recommended CO alarm placement for single floor residence.

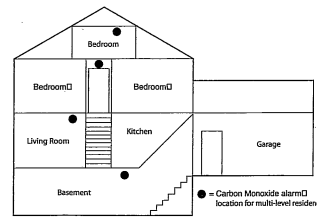

Figure 2: Recommended CO alarm placement for multi-level residence.

8.3 This CO alarm must be mounted on the wall or ceiling.

8.4 WALL LOCATION: Locate the top of the alarm 5 to 6 feet from the floor.

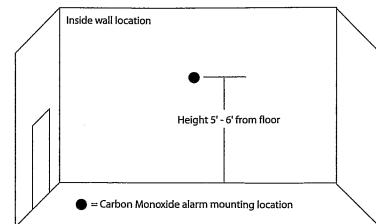

Figure 3: Recommended CO alarm mounting location is 5 to 6 feet from floor.

8.5 CEILING LOCATION: Alarm should be mounted as close as possible to the center of a hallway or room. If this is not possible, the edge of the alarm should be at least 4 inches from any wall.

8.6 LOCATIONS TO AVOID

Placing units where they will not operate properly causes nuisance alarms. To avoid nuisance alarms, do not place units:

- Within 5 feet (1.5m) of any cooking appliance or furnace.

- Near an open window or door, because the fresh air entering the opening may delay CO from reaching the alarm.
- In damp or very humid areas or next to bathrooms with showers. Install detectors at least 10 feet (3 meters) away from bathrooms.
- In very cold or very hot environments or in unheated buildings or outdoor rooms where the temperature can go below or above the operating range of the alarm. Temperature limits for proper operation are 4.4° C to 37.8° C (40° F to 100° F).
- Good ventilation is recommended when household cleaning supplies or similar contaminants are stored or frequently used.

8.7 CONDITIONS WHICH CAN RESULT IN TEMPORARY CO SITUATIONS:

- 8.7.1 Excessive spillage or reverse venting of fuel burning appliances caused by outdoor ambient conditions, such as:
- Wind direction and/or velocity, including high gusts of wind. Heavy air in the vent pipes (cold/humid air with extended periods between cycles).
 - Negative pressure differential resulting from the use of exhaust fans.
 - Simultaneous operation of several fuel burning appliances competing for limited internal air.
 - Vent pipe connections vibrating loose from clothes dryers, furnaces, or water heaters.
 - Obstructions in or unconventional vent pipe designs which can amplify the above situations.

8.7.2 Extended operation of unvented fuel burning devices (range, oven, fireplace, etc.)

8.7.3 Temperature inversions, which can trap exhaust gasses near the ground.

8.7.4 Car idling in an open or closed area garage, or near a home.

9.0 INSTALLATION INSTRUCTIONS: CAUTION! READ CAREFULLY

9.1 Select proper location

9.2 A mounting plate is provided on the back of the alarm. Remove the mounting plate from the back of the alarm by holding the mounting plate and twisting the alarm in the direction indicated by the "OFF" arrow on the alarm cover.

9.3 To insure aesthetic alignment of the alarm with the hallway or wall, the UP ARROW on the mounting plate must be:

- Parallel with the hallway walls when ceiling mounting
- Pointed upward when wall mounting

9.4 Attach the mounting plate on the wall. Be sure the UP text and arrow are facing up. Use the screws and anchors provided to secure the mounting plate.

9.5 WIRING INSTALLATION

Internal terminal block for 14-22 AWG wires. 8 screw terminals at 0.2" (5 mm) spacing.

9.5.1 Drill hole in wall or ceiling at center of plate, and pull system wires through the hole.

9.5.2 Remove alarm cover by using the special tool provided on the three locking tabs on the alarm base. (see figure 4)

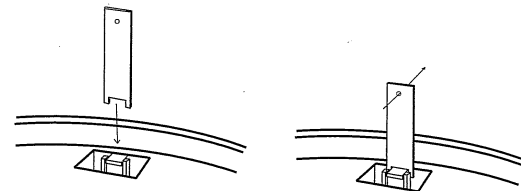

Figure 4

9.5.3 Pull wires through hole at center of alarm base and connect to the internal terminal block as shown on the following wiring diagrams. (see figure 5)

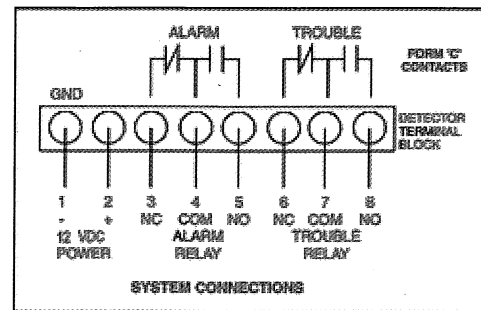

Figure 5

NOTE: The form 'C' relay contacts may be wired either N.O. or N.C. according to system panel requirements. These alarms are not designed to drive auxiliary devices

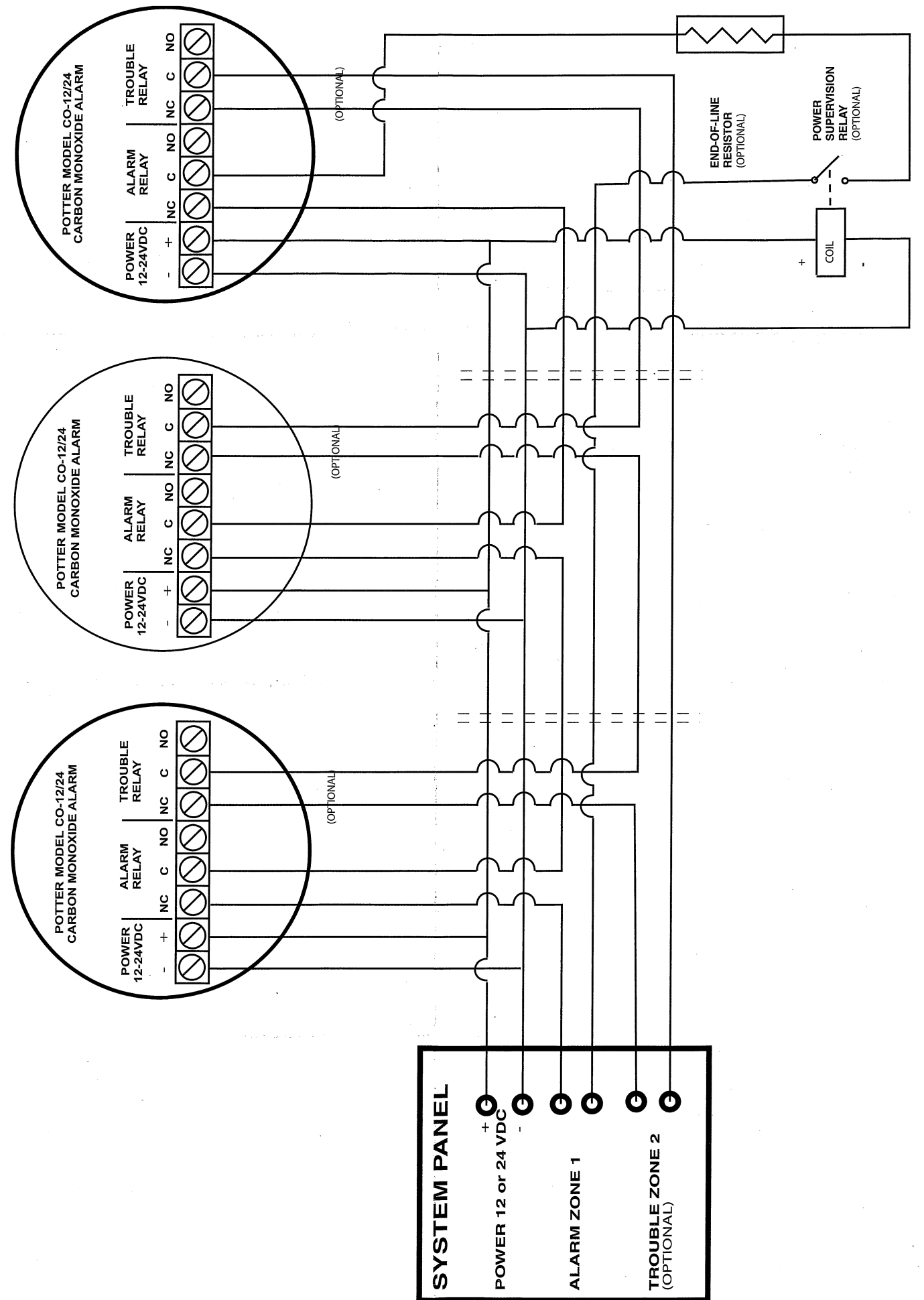

Figure 6. 12-24VDC System Multiple Alarms: Installation Wiring Diagram